



RCK[®]

CLAMPING ELEMENTS

SERIES RCK 11	page 6
SERIES RCK 13	7
SERIES RCK 15	8
SERIES RCK 16	9
SERIES RCK 19	10
SERIES RCK 40	11
SERIES RCK 45	12
SERIES RCK 50	13
SERIES RCK 55	14
SERIES RCK 60	15
SERIES RCK 61	16
SERIES RCK 70	17
SERIES RCK 71	18
SERIES RCK 80	19
SERIES RCK 95	20





MINIMUM HUB DIAMETER CHECK D_m

After choosing the clamping element type with the required characteristics it is necessary to make a check on the minimum extern diameter of the hub (D_m), which has to resist to the solicitations caused by the high pressures developed by the clamping element. The check is purely static and concerns just solicitations caused by the clamping element:

$$D_m \geq D \times \sqrt{\frac{R_s 0.2 + (P_m \times C)}{R_s 0.2 - (P_m \times C)}}$$

Where: D_m = Extern diameter of the hub (mm)

D = Extern diameter of the clamping element (mm)

$R_s 0.2$ = Yield point for permanent elongation of 0.2% (N/mm²)

P_m = Specific pressure exercised by the clamping element on the hub (N/mm²)

C = coefficient of the utilization in function of the hub profile (Look at the pictures below)

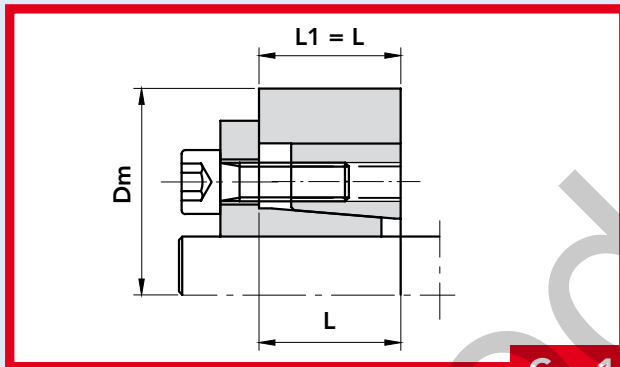

$C = 1$

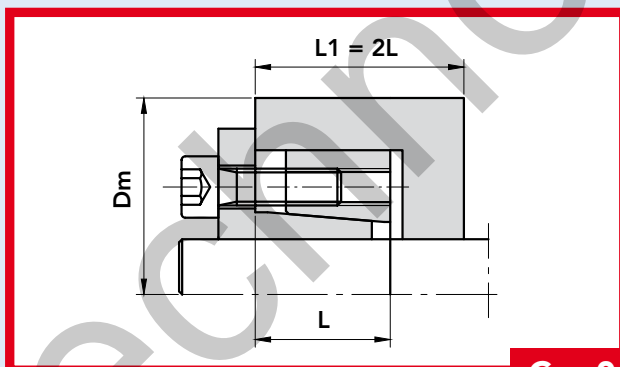
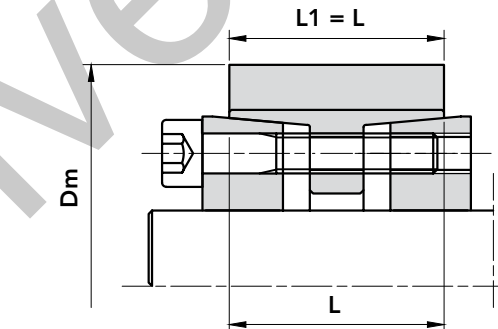

$C = 0.8$

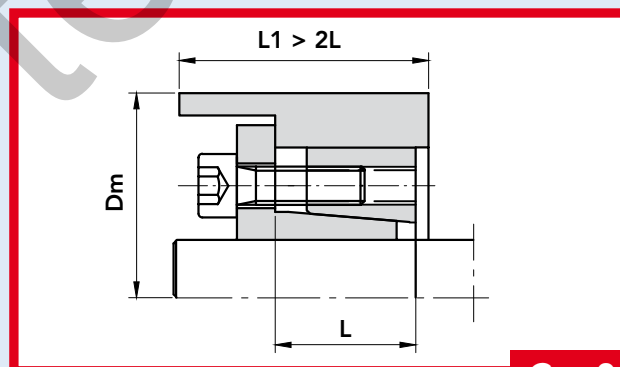
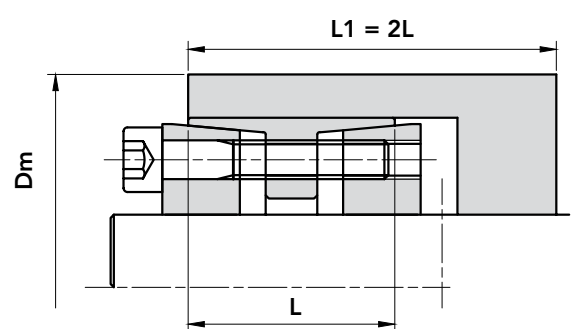

$C = 0.6$

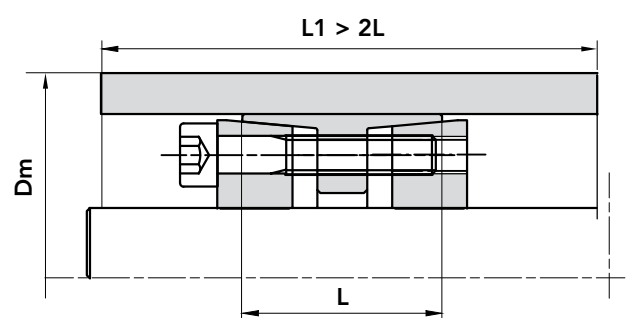



The clamping system connects one or two components parts solidly to the drive shaft, which allows motion to be transmitted or to withstand an axial thrust. Friction connection enables gaps to be eliminated, thereby ensuring greater precision of the keyed components without requiring strict processing tolerances. The thrust cones develop a pressure between the shaft and the hub, which enables pulleys, gears, chain sprockets, drums, flywheels, etc. to be anchored safely. The easy assembly and disassembly features give users many advantages, leading to a further cost saving.

Chiaravalli Group S.p.A. provides its customers with different types of clamping elements, which are designed to cover a broad range of applications.



SHAFT CLAMPING ELEMENTS

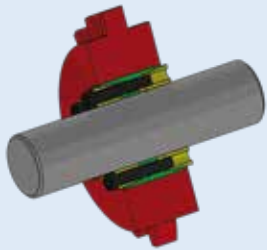

RCK 11

SELF CENTRING RCK 11 TYPE

Suitable for assemblies where special, even heavy-duty conditions are required, achieving maximum friction clamping results. It incorporates the best features of all the models which have been presented. It operates with very high torque values.

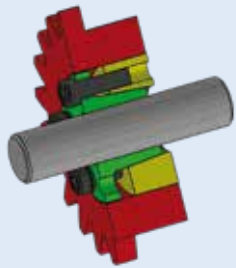

RCK 13

SELF CENTRING RCK 13 TYPE

Suitable for assemblies where good concentricity is required in small spaces with medium- high torque values. It can substitute RCK 40 in some cases.

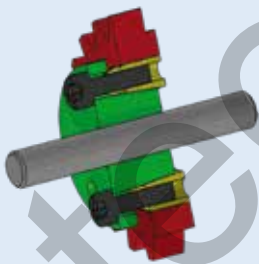

RCK 15

SELF CENTRING RCK 15 TYPE

Suitable for assemblies where axial and radial positioning accuracy is required with medium- high torque values. The main feature is the possibility of varying the internal bores while maintaining the external dimensions constant at only three diameters.

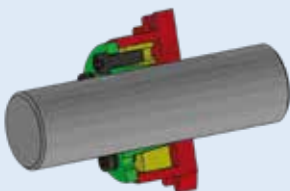

RCK 16

SELF CENTRING RCK 16 TYPE

Suitable for assemblies where concentricity and positioning accuracy is required. It operates with medium- high torque values.

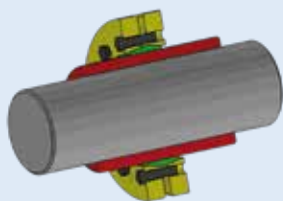
**RCK 19****SELF CENTRING RCK 19 TYPE**

Suitable for hollow shafts, it operates by compressing the hollow shafts on the solid shafts enabling transmission of medium high twisting moments to be achieved.

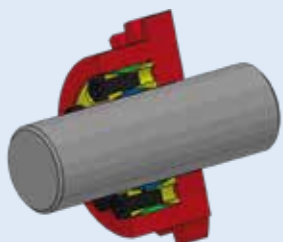
**RCK 40****NOT SELF CENTRING RCK 40 TYPE**

Suitable for general applications, it is not self centring and therefore requires a centring band to ensure perfect concentricity. It operates with medium- high torque values.

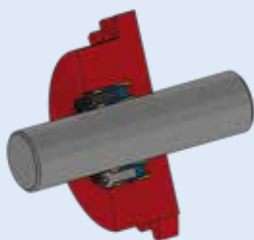
**RCK 45****NOT SELF CENTRING RCK 45 TYPE**

Suitable for applications where medium-low twisting moments are required with, easy rapid assembly and disassembly operation. Not self centring.

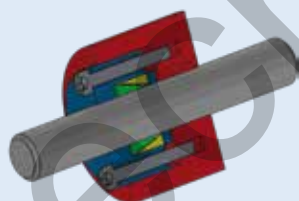
**RCK 50****NOT SELF CENTRING RCK 50 TYPE**

Comprising two tapered rings, must always be mounted with a tightening flange. It operates with low torque values; it isn't self centring.

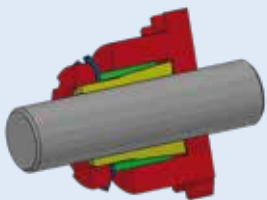
**RCK 55****SELF CENTRING RCK 55 TYPE**

Suitable for assemblies where limited overall dimensions and times are required. It operates with medium-low torque values.

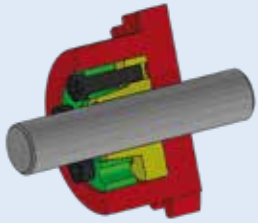

RCK 60

SELF CENTRING RCK 60 TYPE

Suitable for assemblies where a medium-high twisting moment is required. It operates in the opposite mode to RCK 13.

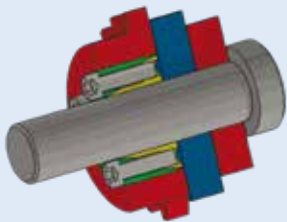

RCK 61

SELF CENTRING RCK 61 TYPE

Enables adjacent components to be clamped to the hub thanks to an axial force achieved during the clamping phase. It operates with medium torque values.

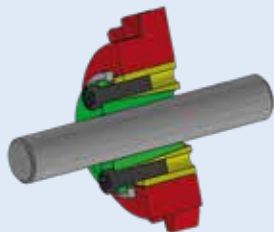

RCK 70-71

SELF CENTRING RCK 70-71 TYPE (RCK 71 eventually with spacer)

The RCK version is suitable for assemblies where concentricity and orthogonal positioning of the parts is required. The RCK 71 version has the same features as RCK 70 with the addition of a spacer ring to completely avoid possible axial displacements. These components operate with medium- high torque values.

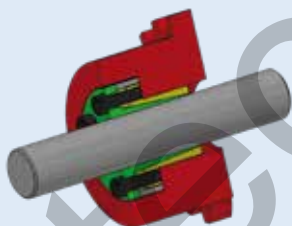

RCK 80

SELF CENTRING RCK 80 TYPE

Suitable for assemblies on hubs with thin walls guarantees both axial and radial positioning precision with medium transmission torque values.

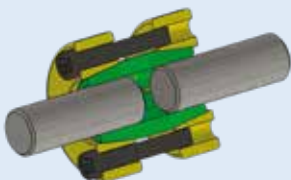

RCK 95

Enables rigid connection between two aligned shafts. It transmits medium-high twisting moments with the advantage of enabling rapid assembly and disassembly.



SELF CENTRING

THE RECOMMENDED MACHINING TOLERANCES FOR THE PRESSURE SURFACES ARE AS FOLLOWS:

Ø h 8 FOR SHAFT

Ø H 8 FOR HUB

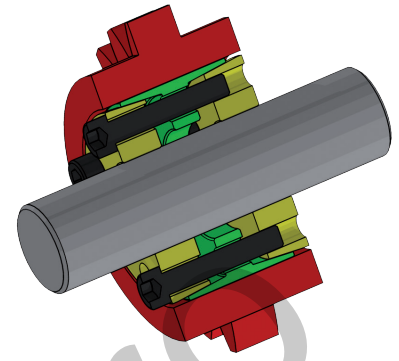
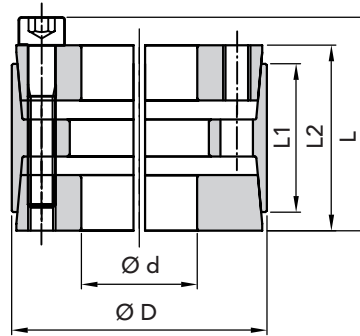

PART NUMBER	DIMENSIONS					maximum torque Mt Nm	CLAMPING PRESSURE			CLAMPING SCREWS DIN 912 MAT. 12.9		EXTRACTION THREAD		WEIGHT Kg
	Ød	ØD	L1	L2	L		Shaft N/mm ²	Hub N/mm ²	N°	Type	Torque Nm	Type	N°	
06110025	25	55	32	40	46	840	295	134	6	M6x35	17	M6	3	0,50
06110028	28	55	32	40	46	940	264	134	6	M6x35	17	M6	3	0,60
06110030	30	55	32	40	46	1000	246	134	6	M6x35	17	M6	3	0,60
06110035	35	60	44	54	60	1360	174	101	7	M6x45	17	M6	3	0,70
06110038	38	75	44	54	62	2740	296	150	7	M8x50	41	M8	3	0,70
06110040	40	75	44	54	62	2880	281	150	7	M8x50	41	M8	3	0,70
06110042	42	75	44	54	62	3030	268	150	7	M8x50	41	M8	3	1,00
06110045	45	75	44	54	62	3240	250	150	7	M8x50	41	M8	3	0,90
06110048	48	80	56	64	72	3950	207	124	8	M8x50	41	M8	3	1,40
06110050	50	80	56	64	72	4150	200	98	8	M8x50	41	M8	3	1,30
06110055	55	85	56	64	72	5150	205	104	9	M8x50	41	M8	3	1,50
06110060	60	90	56	64	72	6200	202	106	10	M8x50	41	M8	4	1,60
06110065	65	95	56	64	72	6750	187	100	10	M8x50	41	M8	4	1,80
06110070	70	110	70	78	88	11500	223	114	10	M10x60	83	M10	4	3,00
06110075	75	115	70	78	88	12300	223	114	10	M10x60	83	M10	4	3,30
06110080	80	120	70	78	88	14500	215	115	11	M10x60	83	M10	4	3,50
06110085	85	125	70	78	88	15400	215	115	12	M10x60	83	M10	5	3,70
06110090	90	130	70	78	88	17800	208	115	12	M10x60	83	M10	5	3,55
06110095	95	135	70	78	88	18700	208	115	12	M10x60	83	M10	5	3,75
06110100	100	145	90	100	112	26300	200	107	11	M12x80	145	M12	4	5,80
06110110	110	155	90	100	112	31800	198	110	12	M12x80	145	M12	5	6,25
06110120	120	165	90	100	112	40400	212	120	14	M12x80	145	M12	5	6,65
06110130	130	180	104	116	130	51500	192	112	12	M14x90	230	M14	5	9,30
06110140	140	190	104	116	130	64700	208	124	14	M14x90	230	M14	7	9,75
06110150	150	200	104	116	130	74200	208	127	15	M14x90	230	M14	6	10,35
06110160	160	210	104	116	130	84500	208	128	16	M14x90	230	M14	7	10,95
06110170	170	225	134	148	164	108200	182	113	14	M16x110	355	M16	6	16,20
06110180	180	235	134	148	164	123250	184	115	15	M16x110	355	M16	7	16,90
06110190	190	250	134	148	164	133800	186	116	16	M16x110	355	M16	7	19,85
06110200	200	260	134	148	164	146000	177	112	16	M16x110	355	M16	7	22,00
06110220	220	285	134	148	164	181000	188	115	18	M16x110	355	M16	8	25,00
06110240	240	305	134	148	164	218000	184	119	20	M16x110	355	M16	9	27,00
06110260	260	325	134	148	164	250000	178	117	21	M16x110	355	M16	10	30,00
06110280	280	355	165	177	197	360000	185	117	18	M20x130	690	M20	8	46,00
06110300	300	375	165	177	197	428000	192	123	20	M20x130	690	M20	9	50,00

ORDERING EXAMPLE:

The following will be ordered with a shaft having $\varnothing d$ 45 with torque value less or equal to 3.200 Nm:

RCK 11 - 45 x 75

Part Number 06110045

CAD drawings available on our site

3D simulation available on the website.

Quantity, availability and prices

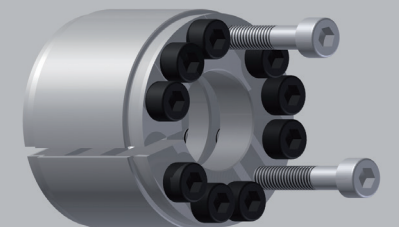



RCK 13 TYPE CLAMPING ELEMENTS

SELF CENTRING

THE RECOMMENDED MACHINING TOLERANCES FOR THE PRESSURE SURFACES ARE AS FOLLOWS:

Ø h 8 FOR SHAFT

Ø H 8 FOR HUB

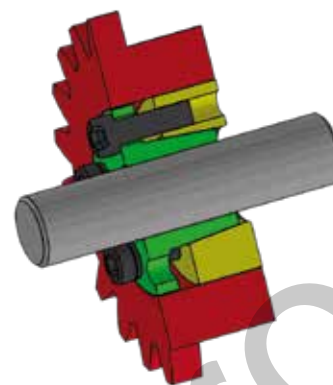
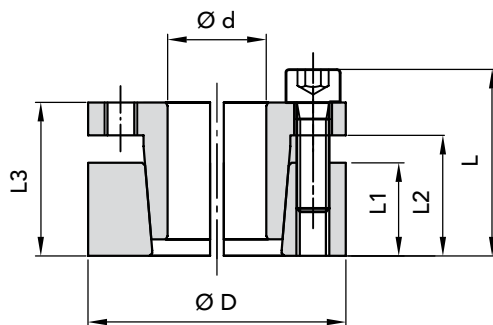

DIMENSIONS

PART NUMBER	DIMENSIONS						maximum torque Mt Nm	CLAMPING PRESSURE		CLAMPING SCREWS DIN 912 MAT. 12.9			EXTRACTION THREAD		WEIGHT Kg
	Ød	ØD	L1	L2	L3	L		Shaft N/mm ²	Hub N/mm ²	N.	Type	Torque Nm	Type	N.	
06130018	18	47	17	22	28	34	310	314	120	5	M6x20	14	M6	3	0,15
06130019	19	47	17	22	28	34	330	300	120	5	M6x20	14	M6	3	0,15
06130020	20	47	17	22	28	34	380	295	125	5	M6x20	14	M6	3	0,15
06130022	22	47	17	22	28	34	410	270	125	5	M6x20	14	M6	3	0,30
06130024	24	50	17	22	28	34	440	243	120	6	M6x20	14	M6	3	0,30
06130025	25	50	17	22	28	34	560	285	140	6	M6x20	14	M6	3	0,30
06130028	28	55	17	22	28	34	630	255	130	6	M6x20	14	M6	3	0,35
06130030	30	55	17	22	28	34	660	235	130	6	M6x20	14	M6	3	0,35
06130032	32	60	17	22	28	34	960	295	155	8	M6x20	14	M6	4	0,40
06130035	35	60	17	22	28	34	1050	270	155	8	M6x20	14	M6	4	0,40
06130038	38	65	17	22	28	34	1140	250	145	8	M6x20	14	M6	4	0,40
06130040	40	65	17	22	28	34	1200	235	145	8	M6x20	14	M6	4	0,40
06130045	45	75	20	25	33	41	2180	290	170	7	M8x25	35	M8	3	0,60
06130050	50	80	20	25	33	41	2430	260	160	7	M8x25	35	M8	3	0,80
06130055	55	85	20	25	33	41	3070	270	175	8	M8x25	35	M8	4	0,80
06130060	60	90	20	25	33	41	3350	245	165	8	M8x25	35	M8	4	0,80
06130065	65	95	20	25	33	41	4080	255	175	9	M8x25	35	M8	3	0,90
06130070	70	110	24	30	40	50	6280	280	180	8	M10x30	70	M10	4	1,59
06130075	75	115	24	30	40	50	6680	260	170	8	M10x30	70	M10	4	1,80
06130080	80	120	24	30	40	50	7130	250	160	8	M10x30	70	M10	4	1,80
06130085	85	125	24	30	40	50	8480	260	180	9	M10x30	70	M10	3	2,00
06130090	90	130	24	30	40	50	9080	250	170	9	M10x30	70	M10	3	2,10
06130095	95	135	24	30	40	50	10580	260	180	10	M10x30	70	M10	4	2,10
06130100	100	145	26	32	44	56	13380	270	190	8	M12x35	125	M12	4	2,80
06130110	110	155	26	32	44	56	14580	240	180	8	M12x35	125	M12	4	3,00
06130120	120	165	26	32	44	56	17880	250	180	9	M12x35	125	M12	4	3,20
06130130	130	180	34	40	52	64	26000	240	170	12	M12x35	125	M12	6	4,80
06130140	140	190	34	40	54	68	26980	210	150	9	M14x40	190	M14	4	5,20
06130150	150	200	34	40	54	68	32980	230	170	10	M14x40	190	M14	5	5,40
06130160	160	210	34	40	54	68	37980	230	170	11	M14x40	190	M14	4	5,70
06130170	170	225	44	50	64	78	44980	180	130	12	M14x40	190	M14	6	8,00
06130180	180	235	44	50	64	78	46980	170	130	12	M14x40	190	M14	6	0,30

ORDERING EXAMPLE:

The following will be ordered with a shaft having ød 30 with a torque value less than or equal 660 Nm:

RCK 13 - 30 x 55

Part Number 06130030

CAD drawings available on our site

3D simulation available on the website.



Quantity, availability and prices





SELF CENTRING

THE RECOMMENDED MACHINING TOLERANCES FOR THE PRESSURE SURFACES ARE AS FOLLOWS:

$\varnothing h 8$ FOR SHAFT

$\varnothing H 8$ FOR HUB

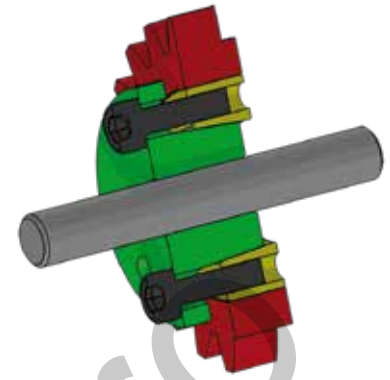
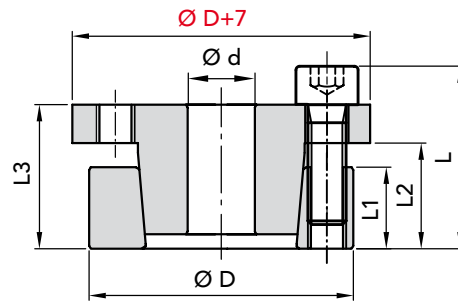

PART NUMBER	DIMENSIONS						maximum torque Mt Nm	CLAMPING PRESSURE		CLAMPING SCREWS DIN 912 MAT. 12.9			EXTRACTION THREAD		WEIGHT Kg
	Ød	ØD	L1	L2	L3	L		Shaft N/mm ²	Hub N/mm ²	N°	Ø x L	Torque Max Nm	Ø	N°	
06150014	14	55	17	22	31	39	290	458	118	4	M8x25	41	M8	2	0,50
06150016	16	55	17	22	31	39	320	400	118	4	M8x25	41	M8	2	0,50
06150018	18	55	17	22	31	39	360	356	118	4	M8x25	41	M8	2	0,50
06150019	19	55	17	22	31	39	380	337	118	4	M8x25	41	M8	2	0,50
06150020	20	55	17	22	31	39	400	320	118	4	M8x25	41	M8	2	0,50
06150022	22	55	17	22	31	39	440	290	118	4	M8x25	41	M8	2	0,50
06150024	24	55	17	22	31	39	480	265	118	4	M8x25	41	M8	2	0,50
06150025	25	55	17	22	31	39	500	255	118	4	M8x25	41	M8	2	0,50
06150028	28	55	17	22	31	39	560	228	118	4	M8x25	41	M8	2	0,40
06150030	30	55	17	22	31	39	600	213	118	4	M8x25	41	M8	2	0,40
06151024	24	65	17	22	31	39	620	332	122	5	M8x25	41	M8	3	0,70
06151025	25	65	17	22	31	39	640	320	122	5	M8x25	41	M8	3	0,70
06151028	28	65	17	22	31	39	720	285	122	5	M8x25	41	M8	3	0,60
06151030	30	65	17	22	31	39	770	267	122	5	M8x25	41	M8	3	0,60
06151032	32	65	17	22	31	39	820	250	122	5	M8x25	41	M8	3	0,60
06151033	33	65	17	22	31	39	850	235	122	5	M8x25	41	M8	3	0,60
06151035	35	65	17	22	31	39	900	228	122	5	M8x25	41	M8	3	0,50
06151038	38	65	17	22	31	39	980	210	122	5	M8x25	41	M8	3	0,50
06151040	40	65	17	22	31	39	1030	200	122	5	M8x25	41	M8	3	0,50
06152030	30	80	20	25	33	41	1080	315	120	7	M8x25	41	M8	3	1,00
06152032	32	80	20	25	33	41	1150	298	120	7	M8x25	41	M8	3	1,00
06152033	33	80	20	25	33	41	1200	282	120	7	M8x25	41	M8	3	1,00
06152035	35	80	20	25	33	41	1260	272	120	7	M8x25	41	M8	3	1,00
06152038	38	80	20	25	33	41	1370	250	120	7	M8x25	41	M8	3	1,00
06152040	40	80	20	25	33	41	1440	238	120	7	M8x25	41	M8	3	0,90
06152042	42	80	20	25	33	41	1510	226	120	7	M8x25	41	M8	3	0,90
06152045	45	80	20	25	33	41	1620	212	120	7	M8x25	41	M8	3	0,80
06152048	48	80	20	25	33	41	1730	198	120	7	M8x25	41	M8	3	0,80
06152050	50	80	20	25	33	41	1800	190	120	7	M8x25	41	M8	3	0,80
06153040	40	80	20	25	33	41	2150	340	169	10	M8x25	41	M8	4	0,95
06153045	45	80	20	25	33	41	2420	302	169	10	M8x25	41	M8	4	0,85
06153050	50	80	20	25	33	41	2700	272	169	10	M8x25	41	M8	4	0,85

ORDERING EXAMPLE:

The following will be ordered with a shaft having $\varnothing d$ 40 with a torque value less than or equal 1030 Nm:

RCK 15 - 40 x 65
Part Number 06151040

CAD drawings available on our site

3D simulation available on the website.



Quantity, availability and prices



RCK 16 TYPE CLAMPING ELEMENTS

SELF CENTRING

THE RECOMMENDED MACHINING TOLERANCES FOR THE PRESSURE SURFACES ARE AS FOLLOWS:

Ø h 8 FOR SHAFT

Ø H 8 FOR HUB

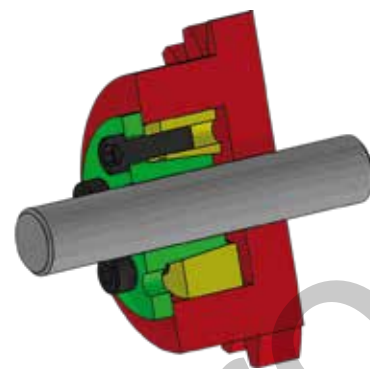
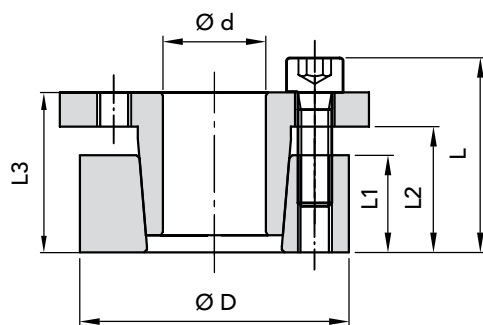

RCK 16 TYPE CLAMPING ELEMENTS

DIMENSIONS

PART NUMBER	Ød	ØD	L1	L2	L3	L	maximum torque Mt Nm	CLAMPING PRESSURE		CLAMPING SCREWS DIN 912 MAT. 12.9			EXTRACTION THREAD		WEIGHT Kg
								Shaft N/mm ²	Hub N/mm ²	N.	Type	Torque Nm	Type	N.	
06160018	18	47	17	22	28	34	260	240	93	5	M6x20	17	M6	3	0,30
06160019	19	47	17	22	28	34	270	230	93	5	M6x20	17	M6	3	0,30
06160020	20	47	17	22	28	34	280	220	95	5	M6x20	17	M6	3	0,30
06160022	22	47	17	22	28	34	300	200	95	5	M6x20	17	M6	3	0,30
06160024	24	50	17	22	28	34	400	215	107	6	M6x20	17	M6	3	0,30
06160025	25	50	17	22	28	34	420	210	105	6	M6x20	17	M6	3	0,30
06160028	28	55	17	22	28	34	470	190	96	6	M6x20	17	M6	3	0,40
06160030	30	55	17	22	28	34	500	180	95	6	M6x20	17	M6	3	0,40
06160032	32	60	17	22	28	34	720	220	115	8	M6x20	17	M6	4	0,40
06160035	35	60	17	22	28	34	790	200	115	8	M6x20	17	M6	4	0,40
06160038	38	65	17	22	28	34	850	185	105	8	M6x20	17	M6	4	0,50
06160040	40	65	17	22	28	34	900	175	105	8	M6x20	17	M6	4	0,50
06160045	45	75	20	25	33	41	1620	215	125	7	M8x25	41	M8	3	0,70
06160050	50	80	20	25	33	41	1820	195	120	7	M8x25	41	M8	3	0,80
06160055	55	85	20	25	33	41	2300	200	130	8	M8x25	41	M8	4	0,90
06160060	60	90	20	25	33	41	2500	185	125	8	M8x25	41	M8	4	0,90
06160065	65	95	20	25	33	41	3050	190	130	9	M8x25	41	M8	3	1,00
06160070	70	110	24	30	40	50	4660	210	135	8	M10x30	83	M10	4	1,90
06160075	75	115	24	30	40	50	5000	195	125	8	M10x30	83	M10	4	2,00
06160080	80	120	24	30	40	50	5300	185	125	8	M10x30	83	M10	4	2,00
06160085	85	125	24	30	40	50	6350	195	135	9	M10x30	83	M10	3	2,00
06160090	90	130	24	30	40	50	6760	185	130	9	M10x30	83	M10	3	2,20
06160095	95	135	24	30	40	50	7900	195	135	10	M10x30	83	M10	4	2,30
06160100	100	145	26	32	44	56	9700	200	140	8	M12x35	145	M12	4	3,00
06160110	110	155	26	32	44	56	10600	180	130	8	M12x35	145	M12	4	3,20
06160120	120	165	26	32	44	56	13000	185	135	9	M12x35	145	M12	4	3,40
06160130	130	180	34	40	52	64	18900	175	125	12	M12x35	145	M12	6	5,20
06160140	140	190	34	40	54	68	20600	165	120	9	M14x40	230	M14	4	5,40
06160150	150	200	34	40	54	68	25100	175	130	10	M14x40	230	M14	5	5,70
06160160	160	210	34	40	54	68	29100	180	135	11	M14x40	230	M14	4	6,00
06160170	170	225	44	50	64	78	34100	140	105	12	M14x40	230	M14	6	8,30
06160180	180	235	44	50	64	78	36100	135	105	12	M14x40	230	M14	6	8,80

ORDERING EXAMPLE:

The following will be ordered with a shaft having ød 75 with a torque value less than or equal 5000 Nm:

RCK 16 - 75 x 115

Part Number 06160075

CAD drawings available on our site

3D simulation available on the website.



Quantity, availability and prices





SELF CENTRING

THE RECOMMENDED MACHINING TOLERANCES FOR THE PRESSURE SURFACES ARE AS FOLLOWS:

Ød h 8 DIAMETER

IMPORTANT:

INTERN TAPERS ARE LUBRICATED WITH PRODUCTS BASED ON MOLYBDENUM BISULPHIDE.

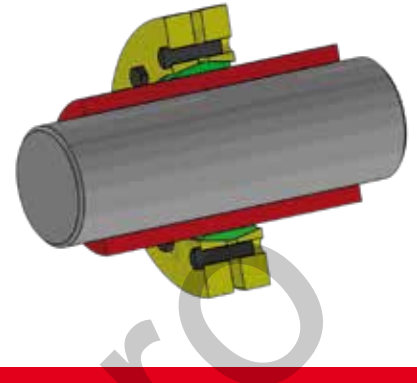
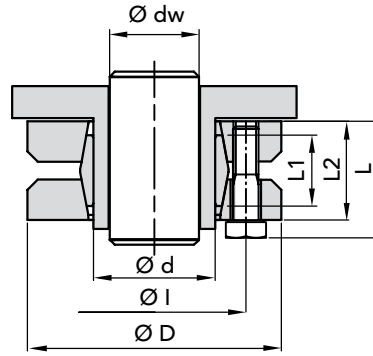

DIMENSIONS

PART NUMBER	Ød	ØD	Ødw	L1	L2	L	Øl	Ødw (dw-d1)	maximum	CLAMPING	CLAMPING SCREWS		WEIGHT	
									torque		SHAFT	DIN 931 MAT. 10.9		
									Nm	N/mm ²	N.	Type	Torque Nm	Kg
06190024	24	50	19 20 21	14	19,5	23	36	0,017	170 210 250	286	6	M5x18	4	0,20
06190030	30	60	24 25 26	16	21,5	25	44	0,017	300 340 380	233	7	M5x18	4	0,30
06190036	36	72	28 30 31	18	23,5	27,5	52	0,032	440 570 630	307	5	M6x20	12	0,40
06190044	44	80	32 35 36	20	25,5	29,5	61	0,032	620 780 860	317	7	M6x20	12	0,60
06190050	50	90	38 40 42	22	27,5	31,5	70	0,032	940 1160 1380	289	8	M6x25	12	0,80
06190055	55	100	42 45 48	23	30,5	34,5	75	0,032	1160 1520 1880	252	8	M6x25	12	1,10
06190062	62	110	48 50 52	23	30,5	34,5	86	0,048	1850 2200 2400	279	10	M6x25	12	1,30
06190068	68	115	50 55 60	23	30,5	34,5	86	0,048	2000 2500 3150	255	10	M6x25	12	1,40
06190075	75	138	55 60 65	25	32,5	37,8	100	0,048	2500 3200 3950	273	7	M8x30	30	1,70
06190080	80	145	60 65 70	25	32,5	37,8	100	0,048	3200 3900 4600	256	7	M8x30	30	1,90
06190090	90	155	65 70 75	30	39	44,3	114	0,048	4750 6000 7250	271	10	M8x35	30	3,30
06190100	100	170	70 75 80	34	44	49,3	124	0,048	6900 7500 9000	258	12	M8x35	30	4,70
06190110	110	185	75 80 85	39	50	56,4	136	0,048	7200 9000 10800	244	9	M10x40	59	5,90
06190125	125	215	85 90 95	42	54	60,4	160	0,069	11000 13000 15000	266	12	M10x40	59	8,30
06190140	140	230	95 100 105	46	60,5	68	175	0,069	15100 17600 20100	264	10	M12x45	100	10,0
06190155	155	265	105 110 115	50	64,5	72	192	0,069	22000 25000 28000	263	12	M12x50	100	15,0
06190165	165	290	115 120 125	56	71	81	210	0,069	31000 35000 39000	277	8	M16x55	250	22,0
06190175	175	300	125 130 135	56	71	81	220	0,079	36000 41000 45000	261	8	M16x55	250	22,0
06190185	185	330	135 140 145	71	86	96	236	0,09	52000 57000 62000	237	10	M16x70	250	24,0

ORDERING EXAMPLE:

The following will be ordered with a shaft having Ød 36 with a torque value less than or equal 440 Nm:

RCK 19 - 36 x 72

Part Number 06190036

CAD drawings available on our site

3D simulation available on the website.



Quantity, availability and prices



RCK 40 TYPE CLAMPING ELEMENTS

NOT SELF CENTERING

THE RECOMMENDED MACHINING TOLERANCES FOR THE PRESSURE SURFACES ARE AS FOLLOWS:

$\varnothing h 8$ FOR SHAFT

$\varnothing H 8$ FOR HUB

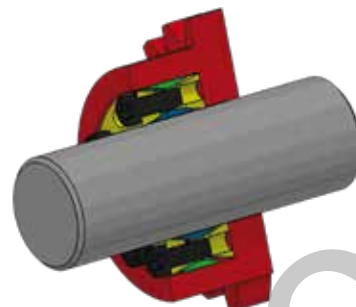
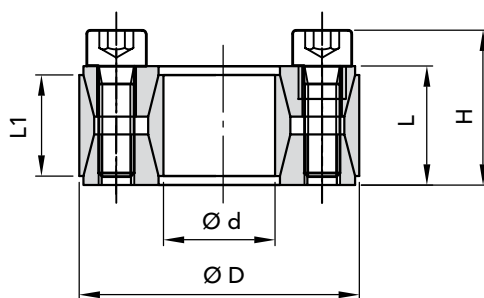

DIMENSIONS

PART NUMBER	Ød	ØD	L1	L	H	maximum torque Mt Nm	CLAMPING PRESSURE		CLAMPING SCREWS DIN 912 MAT. 12.9			EXTRACTION THREAD		WEIGHT Kg
							Shaft N/mm ²	Hub N/mm ²	N.	Type	Torque Nm	Type	N.	
06400019	19	47	17	20	28	255	220	90	8	M6x18	14	M8	2	0,25
06400020	20	47	17	20	28	270	210	90	8	M6x18	14	M8	2	0,24
06400022	22	47	17	20	28	300	195	90	8	M6x18	14	M8	2	0,23
06400024	24	50	17	20	28	360	195	95	9	M6x18	14	M8	3	0,26
06400025	25	50	17	20	28	380	190	95	9	M6x18	14	M8	3	0,25
06400028	28	55	17	20	28	500	187	96	10	M6x18	14	M8	4	0,27
06400030	30	55	17	20	28	530	176	96	10	M6x18	14	M8	4	0,27
06400032	32	60	17	20	28	630	192	105	12	M6x18	14	M8	4	0,32
06400035	35	60	17	20	28	700	180	105	12	M6x18	14	M8	4	0,32
06400038	38	65	17	20	28	860	183	107	14	M6x18	14	M8	4	0,36
06400040	40	65	17	20	28	910	180	110	14	M6x18	14	M8	4	0,34
06400042	42	75	20	24	34	1500	226	125	12	M8x22	35	M10	4	0,48
06400045	45	75	20	24	34	1610	210	125	12	M8x22	35	M10	4	0,57
06400048	48	80	20	24	34	1700	196	115	12	M8x22	35	M10	4	0,59
06400050	50	80	20	24	34	1770	190	115	12	M8x22	35	M10	4	0,60
06400055	55	85	20	24	34	2270	200	130	14	M8x22	35	M10	4	0,63
06400060	60	90	20	24	34	2470	180	120	14	M8x22	35	M10	4	0,69
06400065	65	95	20	24	34	3040	190	130	16	M8x22	35	M12	4	0,73
06400070	70	110	24	28	40	4600	210	130	14	M10x25	70	M12	4	1,26
06400075	75	115	24	28	40	4900	195	125	14	M10x25	70	M12	4	1,33
06400080	80	120	24	28	40	5200	180	120	14	M10x25	70	M12	4	1,40
06400085	85	125	24	28	40	6300	195	130	16	M10x25	70	M12	4	1,49
06400090	90	130	24	28	40	6600	180	125	16	M10x25	70	M12	4	1,53
06400095	95	135	24	28	40	7900	195	135	18	M10x25	70	M12	4	1,62
06400100	100	145	26	33	47	9600	195	135	14	M12x30	125	M14	4	2,01
06400110	110	155	26	33	47	10500	180	125	14	M12x30	125	M14	4	2,15
06400120	120	165	26	33	47	13100	185	135	16	M12x30	125	M14	4	2,35
06400130	130	180	34	38	52	17600	165	115	20	M12x35	125	M14	4	3,51
06400140	140	190	34	38	52	20900	165	125	22	M12x35	125	M14	4	3,85
06400150	150	200	34	38	52	24200	170	125	24	M12x35	125	M14	4	4,07
06400160	160	210	34	38	52	28000	170	130	26	M12x35	125	M14	4	4,30
06400170	170	225	38	44	60	32800	160	120	22	M14x40	190	M16	4	5,80
06400180	180	235	38	44	60	37800	165	125	24	M14x40	190	M16	4	6,00
06400190	190	250	46	52	68	46500	150	115	28	M14x45	190	M16	4	8,50
06400200	200	260	46	52	68	52500	150	115	30	M14x45	190	M16	5	8,60
06400220	220	285	50	56	74	68000	150	115	26	M16x50	295	M18	3	11,0

ORDERING EXAMPLE:

The following will be ordered with a shaft having Ød 75 with a torque value less than or equal 4900 Nm:

RCK 40 - 75 x 115

Part Number 06400075

CAD drawings available on our site

3D simulation available on the website.



Quantity, availability and prices





NOT SELF CENTERING

THE RECOMMENDED MACHINING TOLERANCES FOR THE PRESSURE SURFACES ARE AS FOLLOWS:

$\varnothing h 8$ FOR SHAFT

$\varnothing H 8$ FOR HUB

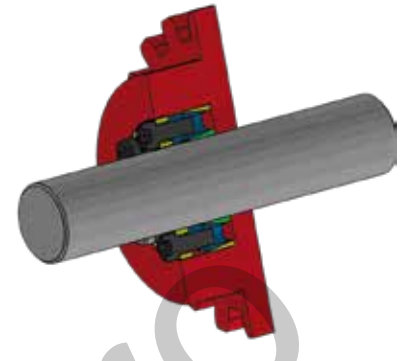
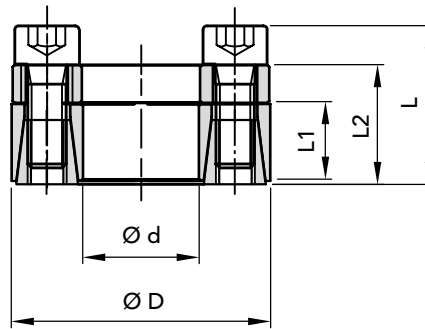

PART NUMBER	DIMENSIONS					maximum torque Mt Nm	CLAMPING PRESSURE		CLAMPING SCREWS DIN 912 MAT. 12.9			EXTRACTION THREAD		WEIGHT Kg
	Ød	ØD	L1	L2	L		Shaft N/mm ²	Hub N/mm ²	N.	Type	Torque Nm	Type	N.	
06450018	18	40	12	18,5	24,5	190	260	120	6	M6x16	16	M8	2	0,20
06450019	19	41	12	18,5	24,5	210	260	120	6	M6x16	16	M8	2	0,25
06450020	20	42	12	18,5	24,5	240	250	120	6	M6x16	16	M8	2	0,24
06450024	24	46	12	18,5	24,5	290	250	120	6	M6x16	16	M8	2	0,25
06450025	25	47	12	18,5	24,5	330	230	120	8	M6x16	16	M8	2	0,25
06450028	28	50	12	18,5	24,5	370	220	120	8	M6x16	16	M8	2	0,30
06450030	30	52	12	18,5	24,5	430	210	120	8	M6x16	16	M8	2	0,30
06450035	35	57	15	22	28	610	170	100	12	M6x16	16	M8	3	0,32
06450038	38	60	15	22	28	680	170	100	12	M6x16	16	M8	3	0,36
06450040	40	62	15	22	28	780	170	100	12	M6x16	16	M8	3	0,40
06450042	42	70	18	28	36	1480	190	110	12	M8x22	41	M10	3	0,45
06450045	45	73	18	28	36	1500	210	130	12	M8x22	41	M10	3	0,57
06450048	48	76	18	28	36	1550	210	130	12	M8x22	41	M10	3	0,59
06450050	50	78	18	28	36	1650	190	120	12	M8x22	41	M10	3	0,61
06450055	55	83	18	28	36	2000	190	120	16	M8x22	41	M10	4	0,63
06450060	60	88	18	28	36	2350	190	120	16	M8x22	41	M10	4	0,69
06450070	70	105	22	35	35	3900	180	120	12	M10x25	70	M12	3	1,25
06450080	80	115	22	35	35	4800	170	120	16	M10x25	70	M12	4	1,40

ORDERING EXAMPLE:

The following will be ordered with a shaft having Ød 55 with a torque value less than or equal 2000 Nm:

RCK 45 - 55 x 83
Part Number 06450055

CAD drawings available on our site

3D simulation available on the website.

Quantity, availability and prices





RCK 50 TYPE CLAMPING ELEMENTS

13

NOT SELF CENTERING

THE RECOMMENDED MACHINING TOLERANCES FOR THE PRESSURE SURFACES ARE AS FOLLOWS:

Ø h 8 FOR SHAFT

Ø H 8 FOR HUB

* cut horizontally

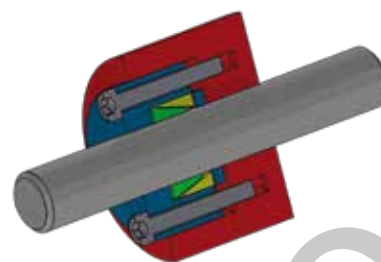
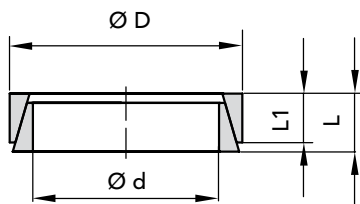

RCK 50 TYPE CLAMPING ELEMENTS

PART NUMBER	DIMENSIONS				Necessary force Kg	maximum torque Mt Nm	CLAMPING PRESSURE		WEIGHT Kg
	Ød	ØD	L1	L			Shaft N/mm ²	Hub N/mm ²	
06500006	*6	9	3,7	4,5	380	2,4	115	75	0,01
06500007	*7	10	3,7	4,5	390	3,0	105	70	0,01
06500008	*8	11	3,7	4,5	530	4,7	120	90	0,01
06500009	9	12	3,7	4,5	1560	7,9	140	105	0,01
06500010	10	13	3,7	4,5	1560	9,5	135	105	0,01
06500012	12	15	3,7	4,5	1560	11,4	115	90	0,01
06500013	13	16	3,7	4,5	1560	13,1	110	90	0,01
06500014	14	18	5,3	6,3	2540	22,3	115	90	0,01
06500015	15	19	5,3	6,3	2540	24,3	110	85	0,01
06500016	16	20	5,3	6,3	2540	27,3	105	85	0,01
06500017	17	21	5,3	6,3	2540	29,8	105	85	0,01
06500018	18	22	5,3	6,3	2540	32,4	100	80	0,01
06500019	19	24	5,3	6,3	3600	49	140	110	0,01
06500020	20	25	5,3	6,3	3600	53	135	105	0,01
06500022	22	26	5,3	6,3	3600	66	135	115	0,01
06500024	24	28	5,3	6,3	3600	73	130	110	0,01
06500025	25	30	5,3	6,3	3600	72	115	95	0,01
06500028	28	32	5,3	6,3	3600	86	115	100	0,01
06500030	30	35	5,3	6,3	3600	91	100	85	0,01
06500032	32	36	5,3	6,3	4500	131	130	115	0,02
06500035	35	40	6	7	5400	171	125	110	0,02
06500036	36	42	6	7	5400	169	115	100	0,02
06500038	38	44	6	7	5400	181	110	95	0,02
06500040	40	45	6,6	8	6600	231	115	105	0,03
06500042	42	48	6,6	8	6600	235	110	95	0,04
06500045	45	52	8,6	10	9900	353	105	95	0,04
06500048	48	55	8,6	10	13200	572	155	135	0,05
06500050	50	57	8,6	10	13200	602	150	130	0,05
06500055	55	62	8,6	10	13200	670	140	125	0,06
06500056	56	64	10,4	12	15720	790	130	115	0,07
06500060	60	68	10,4	12	15720	860	125	110	0,07
06500063	63	71	10,4	12	15720	910	120	105	0,08
06500065	65	73	10,4	12	15720	950	115	100	0,08
06500070	70	79	12,2	14	20960	1380	125	110	0,11
06500071	71	80	12,2	14	20960	1400	120	110	0,12
06500075	75	84	12,2	14	20960	1450	115	100	0,12
06500080	80	91	15	17	29000	2200	125	105	0,20

ORDERING EXAMPLE:

The following will be ordered with a shaft having Ød 24 with a torque value less than or equal 73 Nm:

RCK 50 - 24 x 28

Part Number 06500024

CAD drawings available on our site

3D simulation available on the website.

Quantity, availability and prices





SELF CENTRING

THE RECOMMENDED MACHINING TOLERANCES FOR THE PRESSURE SURFACES ARE AS FOLLOWS:

$\varnothing h 8$ FOR SHAFT

$\varnothing H 8$ FOR HUB

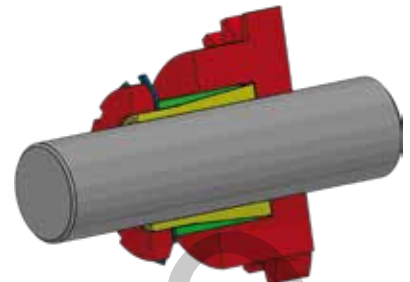
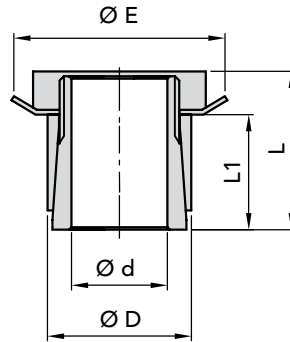

PART NUMBER	DIMENSIONS					maximum torque Mt Nm	CLAMPING PRESSURE		Type	FERRULE		SECURITY WASHER Type	WEIGHT Kg
	Ød	ØD	ØE	L1	L		Shaft N/mm ²	Hub N/mm ²		Thread	Tightening torque Nm		
06550014	14	25	32	23	31	65	80	45	KM4	M20x1	95	MB4	0,10
06550015	15	25	32	23	31	70	80	45	KM4	M20x1	95	MB4	0,11
06550018	18	30	38	24	33	100	75	45	KM5	M25x1,5	160	MB5	0,13
06550019	19	30	38	24	33	105	75	45	KM5	M25x1,5	160	MB5	0,13
06550020	20	30	38	24	33	112	70	45	KM5	M25x1,5	160	MB5	0,15
06550024	24	35	45	29	38	178	65	45	KM6	M30x1,5	220	MB6	0,17
06550025	25	35	45	29	38	185	60	45	KM6	M30x1,5	220	MB6	0,17
06550028	28	40	52	34	44	250	55	40	KM7	M35x1,5	340	MB7	0,28
06550030	30	40	52	34	44	270	50	40	KM7	M35x1,5	340	MB7	0,26
06550035	35	45	58	34	45	390	55	45	KM8	M40x1,5	480	MB8	0,26
06550040	40	50	65	35	46	520	55	45	KM9	M45x1,5	680	MB9	0,33
06550045	45	55	70	35	47	680	60	50	KM10	M50x1,5	870	MB10	0,45
06550050	50	60	75	36	48	880	60	50	KM11	M55x2	970	MB11	0,66
06550055	55	65	80	36	48	1030	60	50	KM12	M60x2	970	MB12	0,72
06550060	60	70	85	36	50	1360	65	55	KM13	M65x2	1300	MB13	0,80

ORDERING EXAMPLE:

The following will be ordered with a shaft having $\varnothing d$ 30 with a torque value less than or equal 270 Nm:

RCK 55 - 30 x 40
Part Number 06550030

CAD drawings available on our site

3D simulation available on the website.



Quantity, availability and prices



RCK 60 TYPE CLAMPING ELEMENTS

SELF CENTRING

THE RECOMMENDED MACHINING TOLERANCES FOR THE PRESSURE SURFACES ARE AS FOLLOWS:

Ø h 8 FOR SHAFT

Ø H 8 FOR HUB

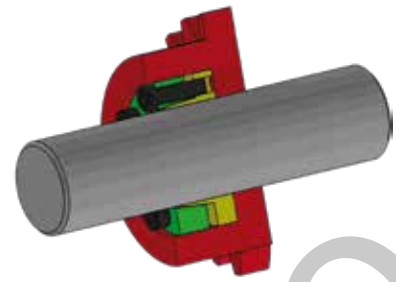
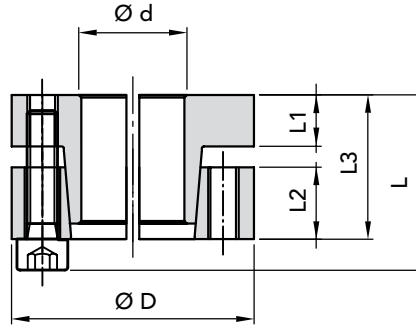

RCK 60 TYPE CLAMPING ELEMENTS

PART NUMBER	DIMENSIONS						maximum torque		CLAMPING PRESSURE		CLAMPING SCREWS DIN 912 MAT. 12.9			EXTRACTION THREAD		WEIGHT Kg
	Ød	ØD	L1	L2	L3	L	Mt Nm	Axial force N.	Shaft N/mm ²	Hub N/mm ²	N.	Type	Torque Nm	Type	N.	
06600020	20	47	10	14	28	34	245	29400	210	93	5	M6x25	17	M6	3	0,24
06600022	22	47	10	14	28	34	265	30000	196	93	5	M6x25	17	M6	3	0,23
06600024	24	50	10	14	28	34	370	32300	215	108	6	M6x25	17	M6	3	0,26
06600025	25	50	10	14	28	34	390	33300	210	108	6	M6x25	17	M6	3	0,25
06600030	30	55	10	14	28	34	480	41200	186	98	6	M6x25	17	M6	3	0,29
06600035	35	60	10	14	28	34	735	44100	186	108	8	M6x25	17	M6	4	0,32
06600038	38	65	10	14	28	34	790	46100	206	103	8	M6x25	17	M6	4	0,36
06600040	40	65	10	14	28	34	830	47000	186	103	8	M6x25	17	M6	4	0,34
06600042	42	75	12	18	35	43	1450	66000	225	132	7	M8x30	41	M8	4	0,48
06600045	45	75	12	18	35	43	1560	70000	220	132	7	M8x30	41	M8	4	0,57
06600050	50	80	12	18	35	43	1650	72000	206	127	7	M8x30	41	M8	4	0,60
06600055	55	85	12	18	35	43	2250	80000	210	132	8	M8x30	41	M8	4	0,63
06600060	60	90	12	18	35	43	2450	83000	186	122	8	M8x30	41	M8	4	0,69
06600065	65	95	12	18	35	43	2890	90000	200	132	9	M8x30	41	M8	3	0,73
06600070	70	110	16	24	46	56	4700	130000	220	140	8	M10x40	83	M10	4	1,26

ORDERING EXAMPLE:

The following will be ordered with a shaft having Ød 30 with a torque value less than or equal 480 Nm:

RCK 60 - 30 x 55

Part Number 06600030

CAD drawings available on our site

3D simulation available on the website.



Quantity, availability and prices





SELF CENTRING

THE RECOMMENDED MACHINING TOLERANCES FOR THE PRESSURE SURFACES ARE AS FOLLOWS:

$\varnothing h 8$ FOR SHAFT

$\varnothing H 8$ FOR HUB

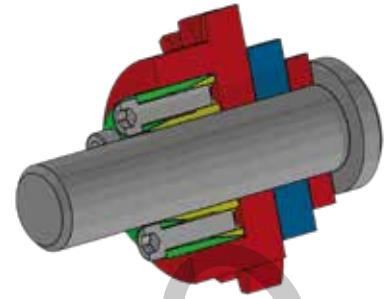
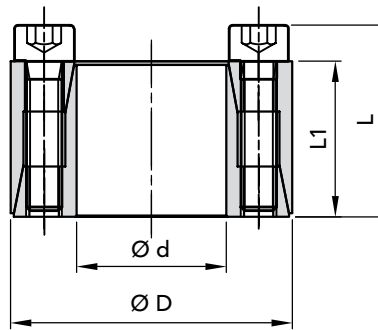

PART NUMBER	DIMENSIONS				maximum torque Mt Nm	CLAMPING PRESSURE		CLAMPING SCREWS DIN 912 MAT. 12.9			EXTRACTION THREAD		WEIGHT Kg
	$\varnothing d$	$\varnothing D$	L1	L		Shaft N/mm ²	Hub N/mm ²	N.	Type	Torque Nm	Type	N.	
06610010	10	20	13	15,5	15	110	55	4	M2,5x12	1,2	M2,5	2	0,02
06610012	12	22	13	15,5	20	90	50	4	M2,5x12	1,2	M2,5	2	0,02
06610014	14	26	17	20	35	105	55	4	M3x16	2,1	M3	2	0,04
06610015	15	28	17	20	40	100	50	4	M3x16	2,1	M3	2	0,04
06610016	16	32	17	21	70	130	65	4	M4x16	4,9	M4	2	0,07
06610018	18	35	21	25	80	115	60	4	M4x20	4,9	M4	2	0,09
06610019	19	35	21	25	85	110	60	4	M4x20	4,9	M4	2	0,08
06610020	20	38	21	26	220	220	115	6	M5x20	9,7	M5	3	0,10
06610022	22	40	21	26	240	200	110	6	M5x20	9,7	M5	3	0,11
06610024	24	47	26	32	380	220	110	6	M6x25	16,2	M6	3	0,20
06610025	25	47	26	32	390	210	110	6	M6x25	16,2	M6	3	0,19

ORDERING EXAMPLE:

The following will be ordered with a shaft having $\varnothing d$ 15 with a torque value less than or equal 40 Nm:

RCK 61 - 15 x 28
Part Number 06610015

CAD drawings available on our site

3D simulation available on the website.



Quantity, availability and prices



RCK 70 TYPE CLAMPING ELEMENTS

SELF CENTRING

THE RECOMMENDED MACHINING TOLERANCES FOR THE PRESSURE SURFACES ARE AS FOLLOWS:

Ø h 8 FOR SHAFT

Ø H 8 FOR HUB

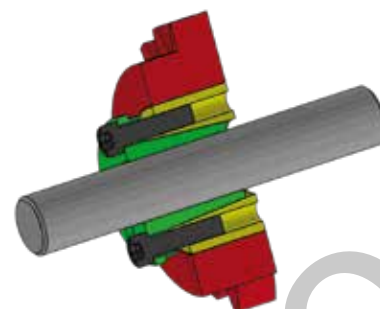
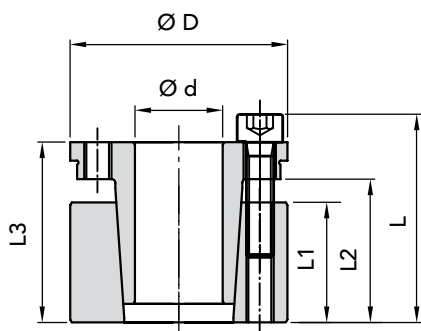

RCK 70 TYPE CLAMPING ELEMENTS

DIMENSIONS

PART NUMBER	Ød	ØD	DIMENSIONS				maximum torque Mt Nm	CLAMPING PRESSURE		CLAMPING SCREWS DIN 912 MAT. 12.9			EXTRACTION THREAD		WEIGHT Kg
			L1	L2	L3	L		Shaft N/mm ²	Hub N/mm ²	N.	Type	Torque Nm	Type	N.	
06700019	19	47	26	31	39	45	350	228	98	4	M6x25	17	M6	2	0,39
06700020	20	47	26	31	39	45	390	231	100	4	M6x25	17	M6	2	0,38
06700022	22	47	26	31	39	45	440	220	95	4	M6x25	17	M6	2	0,37
06700024	24	50	26	31	39	45	519	215	102	6	M6x25	17	M6	3	0,43
06700025	25	50	26	31	39	45	590	230	105	6	M6x25	17	M6	3	0,42
06700028	28	55	26	31	39	45	700	220	110	6	M6x25	17	M6	3	0,45
06700030	30	55	26	31	39	45	760	200	120	6	M6x25	17	M6	3	0,45
06700032	32	60	26	31	39	45	930	230	114	8	M6x25	17	M6	4	0,60
06700035	35	60	26	31	39	45	1030	200	119	8	M6x25	17	M6	4	0,50
06700038	38	65	26	31	39	45	1240	210	124	8	M6x25	17	M6	4	0,60
06700040	40	65	26	31	39	45	1350	200	125	8	M6x25	17	M6	4	0,60
06700042	42	75	30	36	47	55	2170	236	140	6	M8x30	41	M8	3	1,00
06700045	45	75	30	36	47	55	2350	236	140	6	M8x30	41	M8	3	1,00
06700048	48	80	30	36	47	55	2510	218	135	6	M8x30	41	M8	3	1,10
06700050	50	80	30	36	47	55	2580	218	135	6	M8x30	41	M8	3	1,00
06700055	55	85	30	36	47	55	3200	223	145	8	M8x30	41	M8	4	1,10
06700060	60	90	30	36	47	55	3380	198	157	8	M8x30	41	M8	4	1,20
06700065	65	95	30	36	47	55	4160	213	140	8	M8x30	41	M8	4	1,30
06700070	70	110	40	46	57	67	6840	225	143	8	M10x35	83	M10	4	2,20
06700075	75	115	40	46	62	72	7500	210	138	8	M10x35	83	M10	4	2,50
06700080	80	120	40	46	62	72	8100	200	130	8	M10x35	83	M10	4	2,60
06700085	85	125	40	46	62	72	9700	210	145	10	M10x35	83	M10	4	2,80
06700090	90	130	40	46	62	72	10300	200	138	10	M10x35	83	M10	4	2,70
06700095	95	135	40	46	62	72	12100	210	148	10	M10x35	83	M10	4	2,90
06700100	100	145	46	52	77	89	15700	216	148	8	M12x45	145	M12	4	3,90
06700110	110	155	46	52	77	89	17200	196	139	8	M12x45	145	M12	4	4,20
06700120	120	165	46	52	77	89	22500	216	156	10	M12x45	145	M12	4	4,80
06700130	130	180	46	52	77	89	24000	196	140	12	M12x45	145	M12	4	5,00
06700140	140	190	51	59	84	90	30800	196	145	8	M14x45	230	M14	4	6,50
06700150	150	200	51	59	84	90	37150	205	153	10	M14x45	230	M14	5	7,00
06700160	160	210	51	59	84	90	40500	205	155	10	M14x45	230	M14	5	7,00
06700170	170	225	51	59	84	90	40900	163	123	12	M14x45	230	M14	6	8,50
06700180	180	235	51	59	84	90	41300	160	120	12	M14x45	230	M14	6	9,00

ORDERING EXAMPLE:

The following will be ordered with a shaft having Ød 48 with a torque value less than or equal 2510 Nm:

RCK 70 - 48 x 80

Part Number 06700048

CAD drawings available on our site

3D simulation available on the website.



Quantity, availability and prices





SELF CENTRING

THE RECOMMENDED MACHINING TOLERANCES FOR THE PRESSURE SURFACES ARE AS FOLLOWS:

$\varnothing h 8$ FOR SHAFT

$\varnothing H 8$ FOR HUB

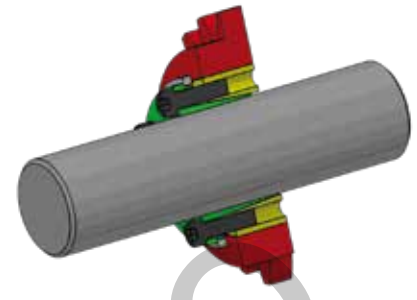
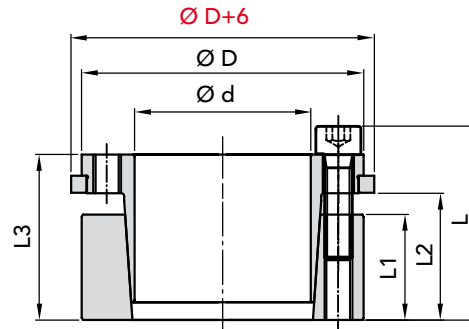

PART NUMBER	DIMENSIONS						maximum torque Mt Nm	CLAMPING PRESSURE		CLAMPING SCREWS DIN 912 MAT. 12.9			EXTRACTION THREAD		WEIGHT Kg
	Ød	ØD	L1	L2	L3	L		Shaft N/mm ²	Hub N/mm ²	N.	Type	Torque Nm	Type	N.	
06710019	19	47	26	31	39	45	300	228	98	4	M6x25	17	M6	2	0,45
06710020	20	47	26	31	39	45	320	231	98	4	M6x25	17	M6	2	0,46
06710022	22	47	26	31	39	45	370	211	99	4	M6x25	17	M6	2	0,50
06710024	24	50	26	31	39	45	430	220	110	6	M6x25	17	M6	3	0,50
06710025	25	50	26	31	39	45	480	226	113	6	M6x25	17	M6	3	0,50
06710028	28	55	26	31	39	45	590	207	108	6	M6x25	17	M6	3	0,60
06710030	30	55	26	31	39	45	650	226	121	6	M6x25	17	M6	3	0,60
06710032	32	60	26	31	39	45	800	201	117	8	M6x25	17	M6	4	0,70
06710035	35	60	26	31	39	45	860	206	121	8	M6x25	17	M6	4	0,60
06710038	38	65	26	31	39	45	1030	201	124	8	M6x25	17	M6	4	0,80
06710040	40	65	26	31	39	45	1130	239	146	8	M6x25	17	M6	4	0,60
06710042	42	75	30	36	47	55	1930	221	138	6	M8x30	41	M8	3	1,20
06710045	45	75	30	36	47	55	1950	221	138	6	M8x30	41	M8	3	1,10
06710048	48	80	30	36	47	55	2180	226	145	6	M8x30	41	M8	3	1,30
06710050	50	80	30	36	47	55	2210	226	146	6	M8x30	41	M8	3	1,10
06710055	55	85	30	36	47	55	2730	226	146	8	M8x30	41	M8	4	1,20
06710060	60	90	30	36	47	55	2910	201	134	8	M8x30	41	M8	4	1,30
06710065	65	95	30	36	47	55	3570	211	145	8	M8x30	41	M8	4	1,40
06710070	70	110	40	46	57	67	5830	226	145	8	M10x35	83	M10	4	2,50
06710075	75	115	40	46	62	72	6330	221	151	8	M10x35	83	M10	4	2,60
06710080	80	120	40	46	62	72	6840	202	142	8	M10x35	83	M10	4	2,80
06710085	85	125	40	46	62	72	8160	221	161	10	M10x35	83	M10	4	2,80
06710090	90	130	40	46	62	72	8670	201	146	10	M10x35	83	M10	4	3,00
06710095	95	135	40	46	62	72	10200	191	141	10	M10x35	83	M10	4	3,00
06710100	100	145	46	52	77	89	13600	201	151	8	M12x45	145	M12	4	5,50
06710110	110	155	46	52	77	89	14870	201	182	8	M12x45	145	M12	4	4,80
06710120	120	165	46	52	77	89	19460	221	162	10	M12x45	145	M12	4	5,50
06710130	130	180	46	52	77	89	20820	202	146	12	M12x45	145	M12	4	6,00
06710140	140	190	51	59	84	90	25410	192	141	8	M14x45	230	M14	4	7,50
06710150	150	200	51	59	84	90	30720	202	152	10	M14x45	230	M14	5	7,70
06710160	160	210	51	59	84	90	33150	202	152	10	M14x45	230	M14	5	8,00
06710170	170	225	51	59	84	90	34000	161	121	12	M14x45	230	M14	6	9,80
06710180	180	235	51	59	84	90	34250	157	122	12	M14x45	230	M14	6	9,80

ORDERING EXAMPLE:

The following will be ordered with a shaft having $\varnothing d$ 30 with a torque value less than or equal 650 Nm:

RCK 71 - 30 x 55

Part Number 06710030

CAD drawings available on our site

3D simulation available on the website.



Quantity, availability and prices



RCK 80 TYPE CLAMPING ELEMENTS

SELF CENTRING

THE RECOMMENDED MACHINING TOLERANCES FOR THE PRESSURE SURFACES ARE AS FOLLOWS:

Ø h 8 FOR SHAFT

Ø H 8 FOR HUB

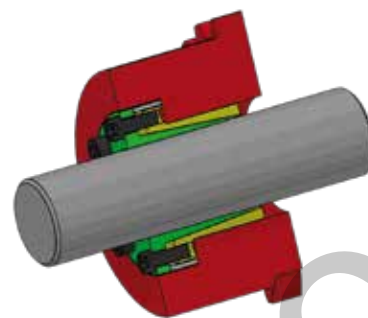
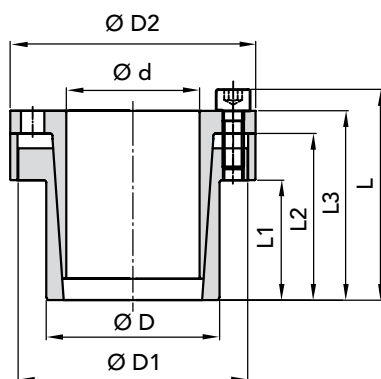

DIMENSIONS

PART NUMBER	Ød	ØD	ØD1	ØD2	L1	L2	L3	L	maximum torque	CLAMPING PRESSURE		CLAMPING SCREWS DIN 912 MAT. 12.9			EXTRACTION THREAD		WEIGHT Kg
									Mt Nm	Shaft N/mm ²	Hub N/mm ²	N.	Type	Torque Nm	Type	N.	
06800006	6	14	22	25	10	18,5	22,5	25,5	12	190	80	3	M3x10	2,2	M3	2	0,10
06800008	8	15	24	27	12	21,5	25,5	29,5	29	205	110	3	M4x12	5	M4	2	0,10
06800009	9	16	25	28	14	23,5	27,5	31,5	31	150	85	3	M4x12	5	M4	2	0,10
06800010	10	16	25	28	14	23,5	27,5	31,5	35	140	85	3	M4x12	5	M4	2	0,11
06800011	11	18	28	32	14	23,5	27,5	31,5	52	170	105	4	M4x12	5	M4	2	0,11
06800012	12	18	28	32	14	23,5	27,5	31,5	58	150	100	4	M4x12	5	M4	2	0,12
06800014	14	23	35	39	14	23,5	27,5	31,5	69	140	80	4	M4x12	5	M4	2	0,12
06800015	15	24	40	45	16	29,5	36,5	42,5	170	158	98	4	M6x18	17	M6	2	0,21
06800016	16	24	40	45	16	29,5	36,5	42,5	180	148	98	4	M6x18	17	M6	2	0,23
06800017	17	26	42	47	19	32,5	39,5	45,5	200	180	125	4	M6x18	17	M6	2	0,25
06800018	18	26	42	47	19	32,5	39,5	45,5	200	180	125	4	M6x18	17	M6	2	0,27
06800019	19	27	43	49	19	32,5	39,5	45,5	210	170	120	4	M6x18	17	M6	2	0,27
06800020	20	28	44	50	19	32,5	39,5	45,5	220	160	115	4	M6x18	17	M6	2	0,27
06800022	22	32	48	54	26	39,5	46,5	52,5	250	115	80	4	M6x18	17	M6	2	0,38
06800024	24	34	50	56	26	39,5	46,5	52,5	395	146	102	6	M6x18	17	M6	3	0,41
06800025	25	34	50	56	26	39,5	46,5	52,5	410	140	102	6	M6x18	17	M6	3	0,45
06800028	28	39	55	61	25,5	39,5	46,5	52,5	465	135	98	6	M6x18	17	M6	3	0,47
06800030	30	41	57	62	25,5	39,5	46,5	52,5	510	127	90	6	M6x18	17	M6	3	0,48
06800032	32	43	59	65	25,5	39,5	46,5	52,5	705	146	108	8	M6x18	17	M6	4	0,49
06800035	35	47	62	69	31,5	45,5	52,5	58,5	790	105	80	8	M6x18	17	M6	4	0,63
06800038	38	50	66	72	31,5	45,5	52,5	58,5	860	100	76	8	M6x18	17	M6	4	0,67
06800040	40	53	69	75	31,5	45,5	52,5	58,5	900	96	72	8	M6x18	17	M6	4	0,73
06800042	42	55	71	78	31,5	45,5	52,5	58,5	940	90	70	8	M6x18	17	M6	4	0,78
06800045	45	59	80	86	45	62,5	71	79	1840	110	85	8	M8x22	41	M8	4	1,23
06800048	48	62	81	87	45	62,5	71	79	2000	105	80	8	M8x22	41	M8	4	1,24
06800050	50	65	86	92	45	62,5	71	79	2100	100	75	8	M8x22	41	M8	4	1,40
06800055	55	71	92	98	55	72,5	81	89	2580	85	65	9	M8x22	41	M8	3	1,70
06800060	60	77	98	104	55	72,5	81	89	2800	75	60	9	M8x22	41	M8	3	1,76
06800065	65	84	105	111	55	72,5	81	89	3050	70	55	9	M8x22	41	M8	3	2,21
06800070	70	90	113	119	65	86,5	96,5	106,5	5250	90	70	9	M10x25	83	M10	3	3,05
06800075	75	95	119	126	65	86,5	96,5	106,5	5600	80	65	9	M10x25	83	M10	3	3,32
06800080	80	100	125	131	65	86,5	96,5	106,5	8000	100	80	12	M10x25	83	M10	4	3,50
06800090	90	112	137	144	65	86,5	96,5	106,5	9000	90	75	12	M10x25	83	M10	4	3,90
06800100	100	125	147	154	65	86,5	96,5	106,5	15000	120	95	18	M10x25	83	M10	4	4,60
06800110	110	140	172	180	90	114	128	140	16000	80	65	12	M12x35	145	M12	4	8,70
06800120	120	155	187	198	90	114	128	140	17500	70	55	12	M12x35	145	M12	4	10,70

ORDERING EXAMPLE:

The following will be ordered with a shaft having Ød 95 with a torque value less than or equal 8000 Nm:

RCK 80 - 80 x 100

Part Number 06800080

CAD drawings available on our site

3D simulation available on the website.



Quantity, availability and prices





RIGID JOINT

THE RECOMMENDED MACHINING TOLERANCES FOR THE PRESSURE SURFACES ARE AS FOLLOWS:

$\varnothing h 8$ FOR SHAFT

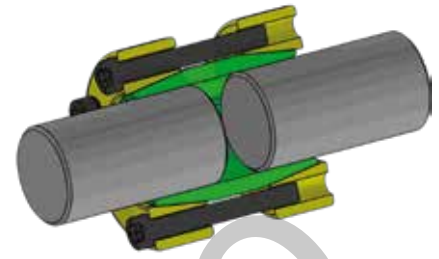
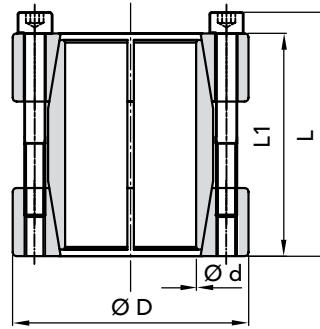

PART NUMBER	DIMENSIONS				maximum torque Mt Nm	CLAMPING PRESSURE Shaft N/mm ² 2	CLAMPING SCREWS DIN 912 MAT. 12.9			WEIGHT Kg
	Ød	ØD	L1	L			N.	Type	Torque Nm	
06950017	17	50	50	56	200	110	4	M6x40	17	0,51
06950018	18	50	50	56	220	110	4	M6x40	17	0,52
06950019	19	50	50	56	230	110	4	M6x40	17	0,50
06950020	20	50	50	56	240	105	4	M6x40	17	0,50
06950024	24	55	60	66	290	120	4	M6x50	17	0,71
06950025	25	55	60	66	450	110	6	M6x50	17	0,69
06950028	28	60	60	66	510	110	6	M6x50	17	0,81
06950030	30	60	60	66	550	105	6	M6x50	17	0,78
06950032	32	63	60	66	580	90	6	M6x50	17	0,85
06950035	35	75	75	83	790	105	4	M8x60	41	1,48
06950038	38	75	75	83	850	100	4	M8x60	41	1,45
06950040	40	75	75	83	900	95	4	M8x60	41	1,40
06950042	42	78	75	83	950	90	4	M8x60	41	1,50
06950045	45	85	85	93	1520	110	6	M8x70	41	2,03
06950048	48	90	85	93	1620	100	6	M8x70	41	2,24
06950050	50	90	85	93	1690	95	6	M8x70	41	2,18
06950055	55	94	85	93	2470	110	8	M8x70	41	2,29
06950060	60	100	85	93	2710	95	8	M8x70	41	2,52
06950065	65	105	85	93	2930	90	8	M8x70	41	2,69
06950070	70	115	100	110	3770	90	6	M10x80	83	3,94

ORDERING EXAMPLE:

The following will be ordered with a shaft having Ød 40 with a torque value less than or equal 900 Nm:

RCK 95 - 40 x 75
Part Number 06950040

CAD drawings available on our site

3D simulation available on the website.



Quantity, availability and prices