

IBC



Telescopic-Runner

TI-I-7005.2 / E



Table of contents

1. Introduction	3
2. Product Description and Applications	4
3. Designs	5
3.1 LCAE Telescopic-Runner	5
3.2 LCAD Telescopic-Runner	5
3.3 LCAH Telescopic-Runner	6
3.4 LCAS Telescopic-Runner	6
3.5 LCBS Telescopic-Runner	6
3.6 Special strokes and customer-specific solutions	6
4. Technical Properties	8
4.1 Materials	8
4.2 Surface platings	8
4.3 Lubrication	8
4.4 Temperature ranges of application	8
4.5 Lengths	8
4.6 Travel speeds	8
4.7 Static load ratings	8
4.8 Limit stops	8
4.9 Fastener spacing	8
4.10 Locking devices	8
5. Technical Dimensioning	9
5.1 Technical variables, definitions and units	9
5.2 Guide to choosing the suitable telescopic guide	9
5.3 Static load	10
5.4 Life time calculation	11
5.5 Bending under load	12
5.6 Travel speeds	12
6. Mounting Advice	13
7. Product Overview	14
7.1 LCAE production series – partial extension	14
7.2 LCAD production series – full extension	16
7.3 LCAH production series – full extension	18
7.4 LCAS production series – full extension	20
7.5 LCBS production series – full extension with track rollers	26
7.6 Locking devices	28
7.7 End position dampings	28
8. IBC Linear Guides with ATCoat Coating	29
9. Designation System	30

I. Introduction

IBC Wälzlager GmbH, Industrial Bearings and Components, is proud to continue in the tradition of Robert Kling Wetzlar GmbH, a company founded in 1918. IBC is widely known for producing high precision rolling bearings that are used in machine tools, separators, centrifuges, compressors, gear boxes, printing machines, textile machines and high speed units. IBC, founded in 1972, is also a brand in the field of drive engineering, special-purpose mechanical engineering and general mechanical engineering. The company's distinguishing features are its efficient and high-precision production of small and medium sized batches and its innovative realisation of a customer's solutions.

IBC started its **Linear Guidance Systems** division to complement the well known and time-tested range of rotational rolling bearings. By continuously developing and improving its product range, IBC has evolved into one of the leading manufacturers of linear motion bearings and telescopic linear motion bearings. IBC produces **linear motion bearings** that are guided in rails that have an X- or U-profile and an internal raceway. This technology allows for very compact and space-saving systems. The most common choices are the **"Telescopic-Runner" telescopic linear motion bearings**, the **"Easy-Runner" linear ball bearings**, and the **track roller linear guidance systems**. Typical uses include the housings of machine tools as well as telescopic pullouts, e.g. those used in the railway supply industry, in medical technology and in warehouse logistics.

IBC offers a broad range of standard products. Since we operate our own production facilities in Germany, we are also in the position to respond to customers' wishes very speedily and flexibly, supplying you with sophisticated products that meet all the required efficiency demands. By way of example, the very smooth run, durability and precise positioning of our linear guides will enable you to design environmentally friendly and energy-saving solutions.

The brochure you are now viewing provides a detailed overview of the IBC range of **"Telescopic-Runner"** telescopic linear motion bearings.

For a detailed overview of the IBC range of **"Easy-Runner"** linear ball bearings please refer to our brochure **TI-I-7011**.

We would also like to draw your attention to our **track roller linear guidance systems** product series (see fig. 1.1 for an

example). **IBC track roller linear guidance systems** are long-lasting and economical and show their strength in routine, everyday situations where machine parts or manually handled parts need to be smoothly moved either by hand or automatically, and heavy weights need to be guided precisely and in an energy-efficient way.

Compared to the **"Telescopic-Runner"** telescopic linear motion bearings and the **"Easy-Runner"** linear ball bearings, the **track roller linear guidance systems** with their roller-based carriers are able to realise much longer distances. Wipers and seals ensure that the closed carriage systems are resistant to any kind of contamination. As the rail guide is available both as a locating and a floating bearing system, designs are able to provide a structurally defined support and continue to function steadily in the event of changes in tolerance, temperature or in the direction of force. You will find more detailed information on these bearings in our **"Linear Motion Bearings"** brochure **TI-I-7001**.

The IBC product range includes **ATCoat thin dense chromium coated high precision rolling bearings and linear guides** that are designed for special applications. The advantage of high precision rolling bearings and linear guides that are coated with ATCoat derives from characteristics that increase their service life and from their very good resistance to wear and corrosion (**IBC Rolling Bearings With ATCoat Coating, ATC Thin Dense Chromium Technology**).

Our comprehensive product range enables us to develop specific and efficient bearing solutions for our customers, and in partnership with our customers.

Companies increasingly rely on global sourcing and the localisation of market-specific products for their business. That is why being able to **service a company's operations all over the world** is becoming increasingly important. IBC Wälzlager has its own production facilities and sales locations in Oberbiel (Germany), Asslar (Germany), Grenchen (Switzerland), Taichung (Taiwan), Aurangabad (India) as well as a sales base in Guangzhou (China). With our facilities, we are able to supply the European markets and have also gained access to the most important new markets of the future.

We will be glad to support you at an early stage of application engineering and will be happy to discuss any plans you may have.



Fig. 1.1: IBC LCX 35 series track roller linear guidance system with CS 35-21.2RS series carrier

2. Product Description and Applications

IBC **Telescopic-Runners** are high-class and precise telescopic linear motion bearings with a very compact design. They are available both as partial extension and as full extension designs. Both cage guided variations (pages 14 to 25 of this brochure) and variations with track rollers (pages 26 and 27 of this brochure) are available.

An inner profile rail is moved within an outer profile rail via cage-guided balls. The inner profile rail thus produces the extension. In the variation with track rollers, the balls are arranged in a fixed manner at the intermediate segment of the telescopic guide. In the cage guided variation, the balls run on suitably formed ball raceways with zero clearance during the extension movement, just as they would in a rolling bearing, where they make rolling contact with 4 contact points in a precise linear movement. In the track roller variation, the ball-bearing mounted rollers run on identical raceways in the same manner. Since only a minimal amount of friction is produced, both track roller guidance systems and ball guidance systems achieve very small displacement forces and acceleration forces, while at the same time exhibiting a high degree of stiffness. The 4 contact points also ensure a noiseless run, even for great loads and high operating speeds. IBC telescopic linear motion bearings are compact in their design and therefore require little installation space.

The outer and inner profile rails are manufactured from high-quality quenched and tempered steel (58CrMoV4). Their ball raceways have been treated by an induction surface hardening process, which allows for **very high load ratings** and **extremely long life times**. IBC Telescopic-Runners are generally characterised by a **high power density** and, as a consequence, they are **very efficient**.

All IBC telescopic linear guides mainly consist of an outer profile

rail and either of an inner profile rail (subsequently called "carriage slider") and a linear ball cage that contains the balls running in it, or of track rollers instead of a ball cage, balls and the carriage slider. The rolling elements permit an even and low-friction transmission of force that simultaneously achieves great stiffness. The linear guides can be manufactured with or without clearance, or they can be preloaded. Limit stops are fitted to limit the preset strokes. We recommend installing external end stops.

The following list, taken from the broad range of possible applications, contains some typical areas of application:

- housings of machine tools and production plants
- transport engineering: door opening systems, battery boxes, etc.
- handling and automation systems
- logistics, shelf access equipment, etc.
- medical technology
- installed equipment in rescue, fire-fighting and municipal-utility vehicles
- aerospace
- printing machines

As the applications within these industries vary greatly, the requirements that the telescopic linear motion bearings need to meet are quite diverse too. Within the handling and automation industry and in transport engineering the focus is on speed, and therefore on high productivity accompanied by low energy consumption. Within the machine tool sector, the emphasis is on great stiffness and on smooth running characteristics. Choosing the right type of guidance system will depend on factors such as load, speed, stroke, and acceleration, but also on factors such as temperature, lubrication, vibration, maintenance, and installation.



Fig. 2.1: LCAD 28H Telescopic-Runner

3. Designs

IBC telescopic linear motion bearings are available with guide lengths between 130 mm and 1,970 mm, both as partial extension designs and as full extension designs that meet individual requirements. The partial extension designs allow for a stroke length of more than 50% of the installation length.

3.1 LCAE Telescopic-Runner

The LCAE series permits partial extension. The length of the carriage slider is equal to the length of the outer profile rail. Moving the carriage slider will achieve a stroke that is greater than half the installation length of the outer profile rail. By removing the stop screw you will be able to achieve two-way pullout. Variants are available that have two LCAE telescopic guides screwed one on top of the other, which leads to a significantly longer overall stroke.

Full extension designs allow for a stroke length that is more than 100% of installation length. All variations described in the following are available in sizes **28H**, **35** and **43**.

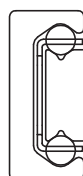

70-028



71-009



Fig. 3.1: LCAE Telescopic-Runner

3.2 LCAD Telescopic-Runner

The LCAD series permits full extension. It consists of two LCAE type telescopic guides, whose carriage sliders have been bolted together and therefore constitute the intermediate telescopic segment. The stroke is slightly longer than the actual installation length of the outer profile rail. Due to this design, approximately the same load ratings are achieved for all feasible fitting positions.

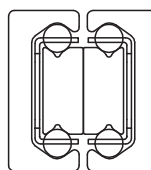

70-029



71-010



Fig. 3.2: LCAD Telescopic-Runner

3.3 LCAH Telescopic-Runner

This series permits full extension. Its design bolts together the two C-shaped outer profiles to form an overall profile shaped like a double T. Great stiffness and outstanding radial load ratings are a mark of this production series. The stroke is slightly longer than the actual installation length of the outer profile rail. For convenient fastening, the carriage sliders can be manufactured with threaded holes, with countersunk drill holes, or with a combination of both.

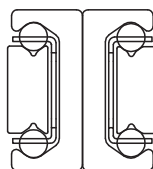

70-030



71-011

3.4 LCAS Telescopic-Runner

This series permits full extension. The outer profile rail is placed in an S-shaped support profile in this design, which therefore achieves a greatly reduced overall width, while simultaneously providing high load carrying capacity and great bending stiffness. One-way and two-way pullout designs are available, depending on the variation that is chosen from this production series.



70-032



71-013

3.5 LCBS Telescopic-Runner

This series permits full extension. The series has a very flat design, which is achieved by way of an improved S-shaped intermediate profile. This series is marked by very high load ratings and a high degree of stiffness. Variations that provide either a one-way or two-way pullout are available. Unlike the LCAS series, this series comes with rollers fitted. Rollers are especially beneficial in the case of vertical applications, high travel speeds or contaminated installation conditions.

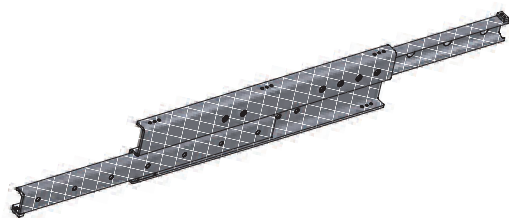

d30-010

3.6 Special strokes and customer-specific solutions

The linear guides described in this catalogue make up the standard range offered by IBC. Depending on the application, we can also offer customer-specific special solutions. Since our linear guides are manufactured by means of a modular system, we are able to manufacture and deliver special solutions at short notice and at a competitive price. Possible variations may include longer strokes, lead-in chamfers, locking devices or interlocks, and synchronised variations.

We are able to provide linear guides for the food industry, for example, by plating the surface of the guides with ATCoat coating or by using components made from high-grade steel. Please contact us for further information on this topic.

All telescopic guides are available from stock or, failing this, can be delivered at short notice, because the parts are standardised to a large extent.



Fig. 3.3: LCAH Telescopic-Runner

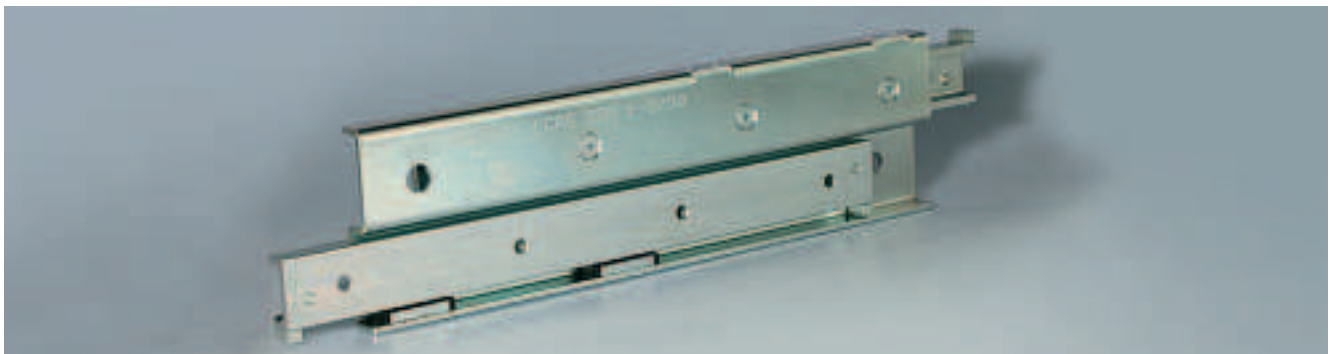

Fig. 3.4: LCAS Telescopic-Runner



Fig. 3.5: LCBS Telescopic-Runner



Fig. 3.6: LCAE Telescopic-Runner with ATCoat coating and special stroke

4. Technical Properties

4.1 Materials

- Material of the outer and inner profile rails: high-quality 58CrMoV4 quenched and tempered steel (1.7792), unless otherwise specified
- Outer and inner profile ball-raceways: inductively surface hardened
- Balls: made of 100Cr6 bearing steel (1.3505); as an option: made of X45Cr13 corrosion resistant steel (1.3541); e.g. for applications within the food industry

4.2 Surface platings

- via electrogalvanisation;
- optional: electroless nickel plated; other coatings available on request; suitable for use with foodstuffs if ATCoat coated, increases life time, good dry running properties

4.3 Lubrication

- for life lubrication with high-quality lubricant for linear guides; optional special lubrication, depending on the application (see page 13 for lubrication time intervals)

4.4 Temperature ranges of application

- Standard: -30 °C to +140 °C
If elastomers are used, e.g. for damped end stops, the permissible range of application is -30 °C to +100 °C; max. +125 °C possible for a short time
- Lower and higher temperature ranges are available on request.

4.5 Lengths

- Installation lengths: 130 mm to 2,000 mm; special lengths available on request
- Stroke lengths: 110 mm to over 2,000 mm; special strokes available on request

4.6 Travel speeds

- max. 0.8 m/s (depending on the application and the installation length)

Please note:

- For fast changes in direction and great acceleration forces, cage slip may occur in unfavourable conditions, especially in the case of long ball cages (see page 13).

4.7 Static load ratings

- C_{0rad} : from 500 N to 67,200 N

4.8 Limit stops

- Each telescopic pullout has been designed to secure the ball cage via limit stops once the maximum stroke is reached.

Please note:

- It is advisable to install external end stops

4.9 Fastener spacing

- The spacing of the holes for fastening is 80 mm as standard. We can provide other fastener spacings on request. The edge distance is 25 mm.

4.10 Locking devices

- Locking devices suited to an inserted and/or extended state are available, depending on the specific production series. If the device you require is not listed in chapter 7.6 or in the product overviews, please contact our technical department for more information.



Fig. 4.1: Telescopic-Runner

5. Technical Dimensioning

5.1 Technical variables, definitions and units

- C = dynamic load rating [N]
- $C_{o_{ax}}$ = permissible static, axial load rating [N]
- $C_{o_{rad}}$ = permissible static, radial load rating [N]
- d = calculated bending under load at each end of the telescopic guide [mm]
- $F_{zul.}$ = permissible tensile force in the direction of extension [N]
- h = stroke coefficient for calculation of bending under load
- L_h = calculated life time [h]
- L_{km} = calculated life span [km]
- M_x = permissible moment of load in X-direction [Nm]
- M_{1x} = effective moment of load in X-direction [Nm]
- M_y = permissible moment of load in Y-direction [Nm]
- M_{2y} = effective moment of load in Y-direction [Nm]
- M_z = permissible moment of load in Z-direction [Nm]
- M_{3z} = effective moment of load in Z-direction [Nm]
- P = external load [N]
- ΣP = equivalent load [N]
- $P_{o_{ax}}$ = effective, static, axial load [N]
- $P_{o_{rad}}$ = effective, static, radial load [N]
- $P_{zul.}$ = permissible load [N]
- S = safety factor that allows for operating conditions
- S_L = safety factor that allows for operating conditions when calculating life time
- w = design-specific coefficient to be considered when calculating bending under load
- X = load rating coefficient for life time calculation

5.2 Guide to choosing the suitable telescopic guide

In order to choose a suitable telescopic guide you will first need to determine the available installation space, the applicable load and the desired stroke. Next, you will need to clarify issues regarding permissible bending under load, operating conditions and the required life time.

With regard to operating conditions, you will need to take into account such influencing factors as operating temperature, levels of contamination, and exceptional impacts (e.g. vibrations). The individual calculation steps are explained on the following pages.

5.3 Static load

The static load values $C_{O_{rad}}$ and $C_{O_{ax}}$, which are contained in the product tables (in chapter 7), refer to the maximum load that is permitted to act on the middle of the third segment of the fully extended profile rail (see figs. 5.1 and 5.2). All values apply to a single telescopic guide, which means that the following applies to a paired arrangement:

$$P_{zul.} = 2 \cdot C_{O_{rad}} \quad [N] \quad [5.1]$$

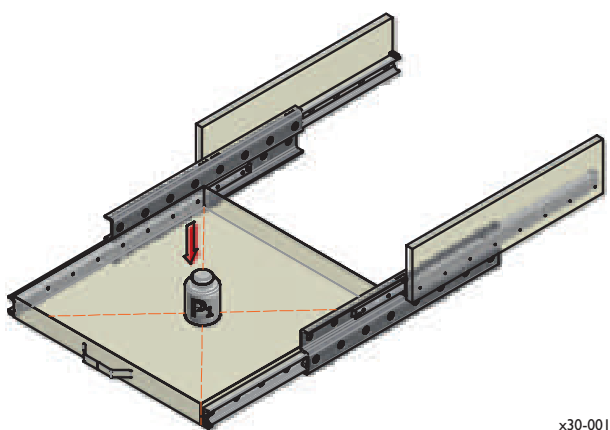

x30-001

Fig. 5.1: Presumed point of load application for paired installation

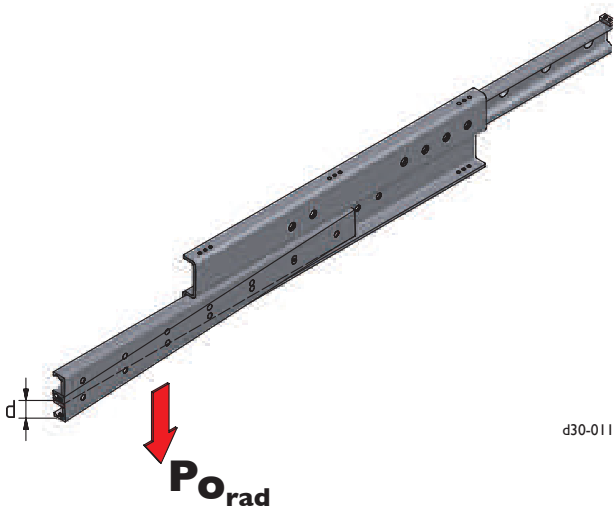

d30-011

Fig. 5.2: Bending under load d for an effective radial load $P_{O_{rad}}$

Telescopic guides are normally subject to external influences, which can be taken into account by factoring in a safety factor. The specific factors are contained in table 5.1:

Influencing variable	Safety factor S
Good installation conditions; precise and stiff mounting; clean environment; fairly constant temperature ranges; No vibrations or shock impact loads; slow changes in direction	1-1.5
Normal installation conditions	1.6-2
Adverse installation conditions; mounting is not very stiff; vibrations and shock impacts; fast changes in direction; heavy contamination	2.1-3.5

Table 5.1: Safety factor S for ambient conditions

Based on the above, the ratio of the effective load P to the static load rating $C_{O_{rad}}$ or $C_{O_{ax}}$ should always amount to the following:

$$\frac{P_{O_{rad}}}{C_{O_{rad}}} \leq \frac{1}{S} \quad \frac{P_{O_{ax}}}{C_{O_{ax}}} \leq \frac{1}{S} \quad [5.2]$$

$$\frac{M_{1x}}{M_x} \leq \frac{1}{S} \quad \frac{M_{2y}}{M_y} \leq \frac{1}{S}$$

$$\frac{M_{3z}}{M_z} \leq \frac{1}{S}$$

If forces and moments of load impact from several directions, then the following applies:

$$\frac{P_{O_{rad}}}{C_{O_{rad}}} + \frac{P_{O_{ax}}}{C_{O_{ax}}} + \frac{M_{1x}}{M_x} + \frac{M_{2y}}{M_y} + \frac{M_{3z}}{M_z} \leq \frac{1}{S} \quad [5.3]$$

You can calculate an external, equivalent load that consists of several load components and load torques by means of formula 5.5 on page 11.

5.4 Life time calculation

The fact that the life time depends on the installation conditions and the ambient conditions is taken into account for calculations by factoring in a safety factor S_L (see table 5.2).

A load rating coefficient X must also be factored into these calculations. Table 5.3 lists the factor for each specific variation.

The calculated life time spans the period from initial operation to the occurrence of the first signs of wear or fatigue.

$$L_{km} = 100 \cdot \left[\frac{(X \cdot C_{O_{rad}})}{\Sigma P} \cdot \frac{1}{S_L} \right]^3 \quad [5.4]$$

In this case, ΣP is the sum of the loads, or the equivalent load, which can be calculated by means of formula 5.5.

Influencing variable	Safety factor S_L
Slow changes in direction, no shocks or vibrations, clean environment	1.3 – 1.8
Few vibrations, normal changes in direction, and normal ambient conditions	1.81 – 2.3
Frequent vibrations and shocks, contaminated environment, frequent and fast changes in direction	2.31 – 3.5

Table 5.2: Safety factor S_L for operating conditions

In-stal- lation length mm	Load rating coefficient X									
	LCAE	LCAH			LCAD			LCAS		LCBS
	all	28H	35	43	28H	35	43	28H	43	43
130	1.4	1.5			1.5					2.15
210	1.4	1.5	1.5	1.5	1.5	1.5	1.5	2.0		2.15
290	1.4	1.5	1.5	1.5	1.85	1.8	1.5	1.9		2.15
370	1.4	1.5	1.5	1.5	3.0	3.0	1.5	1.8		2.15
450	1.4	1.5	1.5	1.5	4.5	4.4	2.1	1.8		2.15
530	1.4	1.9	1.5	1.5	6.2	6.5	3.0	1.7	1.7	2.15
610	1.4	2.5	1.5	1.5	8.2	8.5	4.1	1.7	1.7	2.15
690	1.4	3.15	1.9	1.5	10.5	10.8	5.1	1.7	1.7	2.15
770	1.4	3.9	2.5	1.8	13.1	13.9	6.5	1.65	1.65	2.15
850	1.4	4.9	3.0	2.2	16.3	16.9	8	1.65	1.65	2.15
930	1.4	5.9	3.5	2.6	19.5	20.1	9.5	1.7	1.6	2.15
1,010	1.4	6.9	4.2	3.1	23.0	24.1	11.3	2.0	1.6	2.15
1,090	1.4	8.0	4.9	3.7	26.8	28.0	13.3	2.3	1.7	2.15
1,170	1.4	9.2	5.6	4.2	30.9	32.2	15.2	2.7	1.85	2.15
1,250	1.4		6.5	4.9		37.2	17.5	2.9	2.1	2.15
1,330	1.4		7.4	5.4		41.8	19.6	3.3	2.4	2.15
1,410	1.4		8.3	6.1		47.0	23.1	3.7	2.7	2.15
1,490	1.4		9.3	6.9		53.1	27.9	4.1	3.0	2.15
1,570	1.4			7.7			27.9		3.5	2.15
1,650	1.4			8.5			30.6		3.7	2.15
1,730	1.4			9.35			33.8		4.1	2.15
1,810	1.4			10.2			36.7		4.5	2.15
1,890	1.4			11.1			40.3		4.9	2.15
1,970	1.4			12			43.4		5.3	2.15

Table 5.3: Load rating coefficient X

Method of calculation

Provided the effective static load P_0 is equivalent to the maximum permissible value $C_{O_{rad}}$, and provided good operating conditions ($S_L = 1$) apply, then the calculated life time $L_{km} = 100$ km.

For several loads, the impacting overall load is calculated by means of the following formula:

$$\Sigma P = P_{O_{rad}} + \left[\frac{P_{O_{ax}}}{C_{O_{ax}}} + \frac{M_{1x}}{M_x} + \frac{M_{2y}}{M_y} + \frac{M_{3z}}{M_z} \right] \cdot C_{O_{rad}} \quad [N] \quad [5.5]$$

5.5 Bending under load (see fig. 5.2)

Subject to simplification, bending under load, which occurs at the end of a single, fully extended telescopic guide, can be calculated by means of the following formula:

$$d = \frac{h}{w} \cdot P \quad [\text{mm}] \quad [5.6]$$

Determine the load P in the way described under point 5.3 (fig. 5.2) for this purpose.

Design coefficient w	
Design	w
LCAH 28H	17
LCAH 35	54
LCAH 43	120
LCAD 28H	8
LCAD 35	13
LCAD 43	56
LCAS 28H	180
LCAS 35	470
LCAS 43	800
LCBS 43	800

Table 5.4: Design coefficient w

Stroke coefficient h	
Stroke [mm]	h
600	0.2
800	0.8
1,000	1.3
1,200	2.4
1,400	3.9
1,600	6.0
1,800	8.2
2,000	11.2
2,200	15.0

Table 5.5: Stroke coefficient h

Please note: The calculated value for bending under load presupposes that the adjacent construction has been designed to be stiff. This should be taken into account especially with regard to the LCAE production series (the overall length of both telescopic rail segments must be bolted to the adjacent construction).

5.6 Travel speed

Due to the overall design, the intermediate segment that is carried along with the other segments affects maximum travel speed. As a result, whereas the maximum permissible travel speed for a telescopic guide with an installation length of 400 mm is 0.8 m/s, this value drops to 0.2 m/s for an installation length of 2,000 mm. The values in between are linearly dependent (for an installation length of 1,200 mm the maximum permissible travel speed is therefore 0.5 m/s, for instance). If you have any further questions on this topic, please speak to our technical department.



Fig. 5.3: LCAS Telescopic-Runner

6. Mounting Advice

Stiffness, a smooth run and durability are important characteristics of IBC telescopic linear motion bearings. The bearings are also compact in their design and easy to assemble.

The easy-to-assemble design of the bearings significantly reduces maintenance and shutdown times and therefore cuts costs.

■ Fitting position

It is advisable to mount telescopic guides in a horizontal or near-horizontal fitting position. For installations where guides are mounted in a vertical position it cannot be completely ruled out that the ball cage will move downward if the stroke is not fully utilised. This is due to the specific guide design. Assuming the least favourable scenario, this movement of the cage will negatively impact operation conditions and/or life time. If you are operating such an installation, it is advisable to carry out a no-load stroke from time to time in order to shift the cage back into its correct position. From a technical point of view, we would advise you to install roller telescopic guides (e.g. the LCBS type) if you are contemplating a vertical design. Please contact our technical department for more information on this issue.

■ End stops

We recommend you provide external end stops. The internally fitted stops have only been designed to limit the cage.

■ Paired installation

For the LCAS and LCBS telescopic guides that are installed in pairs, the load should be fastened to the bottom movable telescopic segment, if possible (see fig. 6.1).

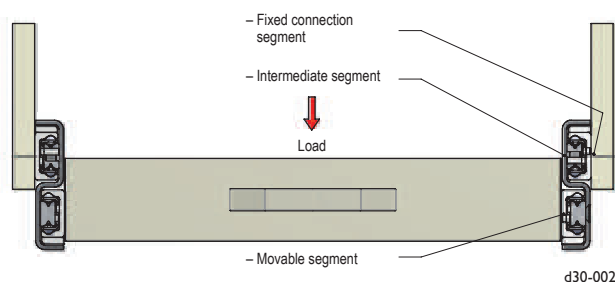

Fig. 6.1 Mounting recommendation for the LCAS and LCBS Telescopic-Runners

■ Two-way stroke

Due to their specific design, the position of the intermediate segment in the case of full extension designs is only defined when the pullout is in its fully extended state. In unfavourable applications, the intermediate segment may also protrude in the zero position in the case of two-way stroke designs. You can remedy this problem by using synchronised telescopic pullouts that carry the intermediate segments along with them

in a defined manner. Please contact our technical department for more information on this issue.

■ Lubrication time intervals

During manufacture, IBC telescopic guides are lubricated for life with high-grade special grease for linear guides. Re-lubrication is advisable at certain intervals, depending on ambient conditions, operating temperatures, speeds, operating frequency, etc. Should you lack practical experience in this matter, we recommend you re-lubricate after 6 to 12 months of service life.

■ Fastening screws

As a standard solution, countersunk screws according to German standard DIN 7991 are used, appropriate to the relevant overall size. If you wish to have a cylindrical countersink for the fastening screws machined into the outer profile rail, the screws will be supplied by IBC, as you will need a very flat head. Always use screws of strength class 10.9. Typical tightening torques are:

M5: 8.1 Nm | M6: 14.0 Nm | M8: 34.3 Nm

■ Utilisation of fastening holes

Some telescopic designs will not allow you to use all the fastening holes. This fact is mentioned in the relevant product table. Generally speaking, these holes can remain unused. In exceptional cases, however, especially if a two-way stroke has been realised, you can reach the fastening holes by loosening the stop screws and extending the carriage slider as far as you need. Once you have finished, re-tighten the stop screws.

■ Installation without clearance

The telescopic guides are normally installed without clearance. However, we can supply variations with an increased preload on request. Please contact our technical department for more information on this issue.

■ Cage slip

Under normal operating conditions, the cage moves in synchronisation with the carriage slider, but at half its speed; or, to put it another way, the ball cage follows the relevant stroke, albeit travelling half the distance. In unfavourable operating conditions, e.g. fast-changing acceleration or heavily fluctuating strokes, it is not always possible to avoid cage slip from occurring. In this case, you should schedule a no-load stroke, if possible, in order to re-position the cage. If strokes fluctuate, you should also ensure adequate dimensioning of the drive that is used. You can use a friction coefficient of 0.1 for the relevant calculations.

A note on using the product tables on the next pages:

- All load ratings specified apply to a single telescopic guide in continuous operation.

7. Product Overview

7.1 LCAE 28H series – partial extension (> 50% stroke length) LCAE 35 series – partial extension (> 50% stroke length)

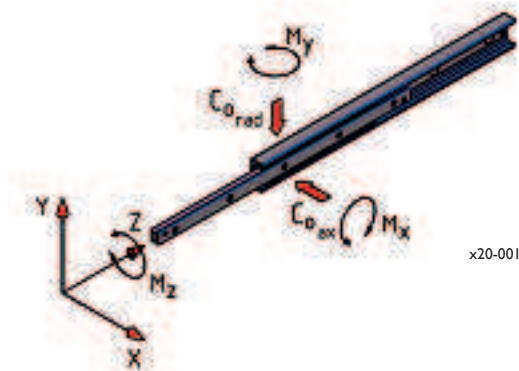

Dimension	Profile size		
	28H	35	43
A	28	35	43
B	12.9	17	22
C	12.3	16.5	21
n1	Ø 5.5	Ø 6.5	Ø 8.5
n2	M5	M6	M8

Designation	Stroke mm	Telescopic rail			Load ratings		Permissible moments of load		
		L mm	no. of holes	weight kg	C_{0rad} N	C_{0ax} N	M_x Nm	M_y Nm	M_z Nm
LCAE 28H-0130	74	130	2	0.29	645	452	30	23	17
LCAE 28H-0210	116	210	3	0.46	1,165	816	86	60	27.5
LCAE 28H-0290	148	290	4	0.64	2,019	1,413	190	135	41
LCAE 28H-0370	190	370	5	0.81	2,543	1,780	309	215	52
LCAE 28H-0450	232	450	6	0.99	3,069	2,148	450	316	64
LCAE 28H-0530	274	530	7	1.17	3,595	2,517	625	438	74
LCAE 28H-0610	315	610	8	1.34	4,151	2,906	822	579	83.5
LCAE 28H-0690	357	690	9	1.52	4,666	3,266	1,055	738	95
LCAE 28H-0770	399	770	10	1.69	5,192	3,634	1,310	916	107
LCAE 28H-0850	432	850	11	1.87	6,045	4,232	1,667	1,166	120
LCAE 28H-0930	475	930	12	2.05	6,549	4,584	1,991	1,392	129
LCAE 28H-1010	517	1,010	13	2.22	7,074	4,952	2,333	1,637	141
LCAE 28H-1090	559	1,090	14	2.39	7,709	5,267	2,709	1,896	151
LCAE 28H-1170	601	1,170	15	2.57	8,125	5,688	3,111	2,178	162
LCAE 35-0210	127	210	3	0.65	1,090	763	90	63	37
LCAE 35-0290	159	290	4	0.87	2,101	1,471	218	155	56
LCAE 35-0370	203	370	5	1.05	2,686	1,880	348	247	69
LCAE 35-0450	247	450	6	1.30	3,271	2,289	515	365	80.5
LCAE 35-0530	279	530	7	1.55	4,350	3,045	787	553	101
LCAE 35-0610	323	610	8	1.85	4,932	3,452	1,027	722	113
LCAE 35-0690	367	690	9	2.00	5,514	3,860	1,296	914	125
LCAE 35-0770	399	770	10	2.25	6,614	4,629	1,711	1,203	143.5
LCAE 35-0850	443	850	11	2.55	7,192	5,035	2,063	1,446	157
LCAE 35-0930	487	930	12	2.68	7,773	5,440	2,441	1,713	170
LCAE 35-1010	519	1,010	13	2.90	8,882	6,218	3,002	2,104	186
LCAE 35-1090	563	1,090	14	3.15	9,504	6,609	3,457	2,422	201
LCAE 35-1170	607	1,170	15	3.40	10,037	7,026	3,946	2,764	215
LCAE 35-1250	639	1,250	16	3.63	11,288	7,798	4,648	3,256	232
LCAE 35-1330	683	1,330	17	3.85	11,728	8,209	5,211	3,652	244.5
LCAE 35-1410	727	1,410	18	4.08	12,338	8,726	5,809	4,070	257
LCAE 35-1490	759	1,490	19	4.30	13,423	9,396	6,654	4,663	273

Removing the stop screw in the outer profile rail will permit a two-way stroke.

7.1 LCAE 43 – partial extension (> 50% stroke length)

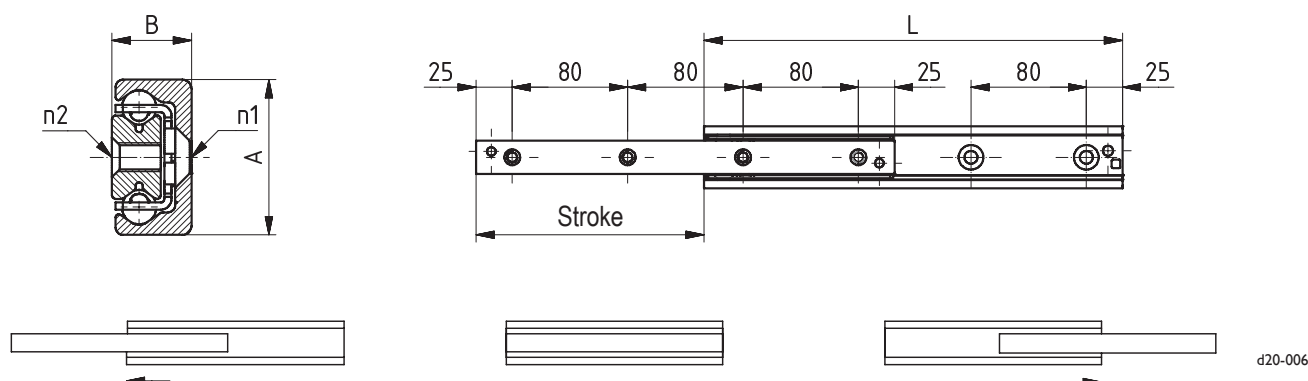

Designation	Stroke mm	Telescopic rail			Load ratings		Permissible moments of load		
		L mm	no. of holes	weight kg	$C_{O_{rad}}$ N	$C_{O_{ax}}$ N	M_x Nm	M_y Nm	M_z Nm
LCAE 43-0210	123	210	3	1.09	1,700	1,190	123	89	62
LCAE 43-0290	158	290	4	1.51	3,033	2,123	294	204	96.5
LCAE 43-0370	208	370	5	1.92	3,546	2,482	444	313	119
LCAE 43-0450	243	450	6	2.34	4,909	3,436	735	514	151
LCAE 43-0530	278	530	7	2.76	6,308	4,415	1,092	766	184
LCAE 43-0610	313	610	8	3.17	7,728	5,410	1,525	1,069	210
LCAE 43-0690	363	690	9	3.59	8,185	5,730	1,853	1,297	240
LCAE 43-0770	398	770	10	4.00	9,490	6,533	2,405	1,687	273
LCAE 43-0850	433	850	11	4.42	10,617	7,432	3,030	2,120	305
LCAE 43-0930	483	930	12	4.84	11,477	8,034	3,489	2,442	331
LCAE 43-1010	518	1,010	13	5.25	12,902	9,031	4,233	2,964	362.5
LCAE 43-1090	568	1,090	14	5.66	13,360	9,604	4,775	3,343	384
LCAE 43-1170	603	1,170	15	6.08	14,774	10,342	5,636	3,945	417
LCAE 43-1250	638	1,250	16	6.50	16,048	11,198	6,575	4,602	450
LCAE 43-1330	688	1,330	17	6.92	16,649	11,654	7,237	5,067	470.5
LCAE 43-1410	723	1,410	18	7.34	17,963	12,618	8,300	5,809	505
LCAE 43-1490	758	1,490	19	7.75	19,094	13,366	9,427	6,601	538
LCAE 43-1570	793	1,570	20	8.16	20,704	14,532	10,630	7,442	572
LCAE 43-1650	843	1,650	21	8.58	21,378	14,964	11,476	8,032	593.5
LCAE 43-1730	878	1,730	22	9.00	22,796	15,962	12,799	8,961	626
LCAE 43-1810	928	1,810	23	9.41	23,249	16,274	13,722	9,603	650
LCAE 43-1890	963	1,890	24	9.83	24,213	17,142	15,170	10,619	684
LCAE 43-1970	1,013	1,970	25	10.24	25,122	17,585	16,169	11,320	709

Removing the stop screw in the outer profile rail will permit a two-way stroke.



7.2 LCAD 28H series – full extension (>100% stroke length) LCAD 35 series – full extension (>100% stroke length)

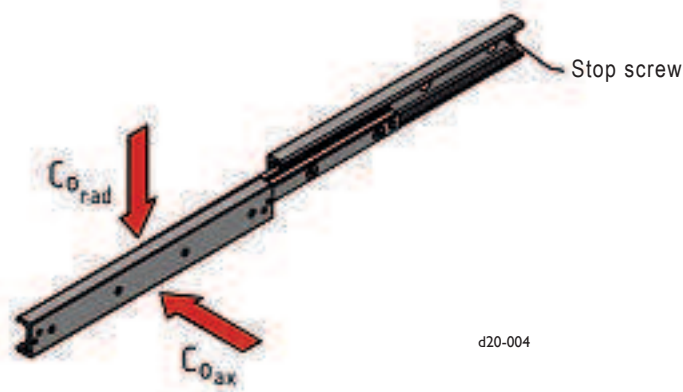

Dimension	Profile size		
	28H	35	43
A	28	35	43
B	26	34	44
n1	Ø 5.5	Ø 6.5	Ø 8.5

Designation	Stroke mm	Telescopic rail			Load ratings	
		L mm	no. of holes	weight kg	$C_{O_{rad}}$ N	$C_{O_{ax}}$ N
LCAD 28H-0130	148	130	2	0.47	244	172
LCAD 28H-0210	232	210	3	0.92	444	313
LCAD 28H-0290	296	290	4	1.28	632	545
LCAD 28H-0370	380	370	5	1.63	496	490
LCAD 28H-0450	464	450	6	1.98	405	405
LCAD 28H-0530	548	530	7	2.33	342	342
LCAD 28H-0610	630	610	8	2.68	298	298
LCAD 28H-0690	714	690	9	3.04	263	263
LCAD 28H-0770	798	770	10	3.39	234	234
LCAD 28H-0850	864	850	11	3.74	220	220
LCAD 28H-0930	950	930	12	4.09	200	200
LCAD 28H-1010	1,034	1,010	13	4.44	183	183
LCAD 28H-1090	1,118	1,090	14	4.80	170	170
LCAD 28H-1170	1,202	1,170	15	5.15	157	157
LCAD 35-0210	254	210	3	1.15	409	286
LCAD 35-0290	318	290	4	1.60	684	569
LCAD 35-0370	406	370	5	2.05	534	534
LCAD 35-0450	494	450	6	2.55	439	439
LCAD 35-0530	558	530	7	3.00	403	403
LCAD 35-0610	646	610	8	3.55	346	346
LCAD 35-0690	734	690	9	3.90	304	304
LCAD 35-0770	798	770	10	4.45	286	286
LCAD 35-0850	886	850	11	4.90	256	256
LCAD 35-0930	974	930	12	5.30	232	232
LCAD 35-1010	1,038	1,010	13	5.80	221	221
LCAD 35-1090	1,126	1,090	14	6.25	205	205
LCAD 35-1170	1,214	1,170	15	6.70	187	187
LCAD 35-1250	1,278	1,250	16	7.15	181	181
LCAD 35-1330	1,366	1,330	17	7.60	169	169
LCAD 35-1410	1,454	1,410	18	8.10	160	160
LCAD 35-1490	1,518	1,490	19	8.65	153	153

If the stop screws are removed, then the overall two-way stroke will be twice the stroke specified in this table. Locking devices for the device in its extended and/or inserted state are available for this production series (single stroke) as standard.

7.2 LCAD 43 series – full extension (>100% stroke length)

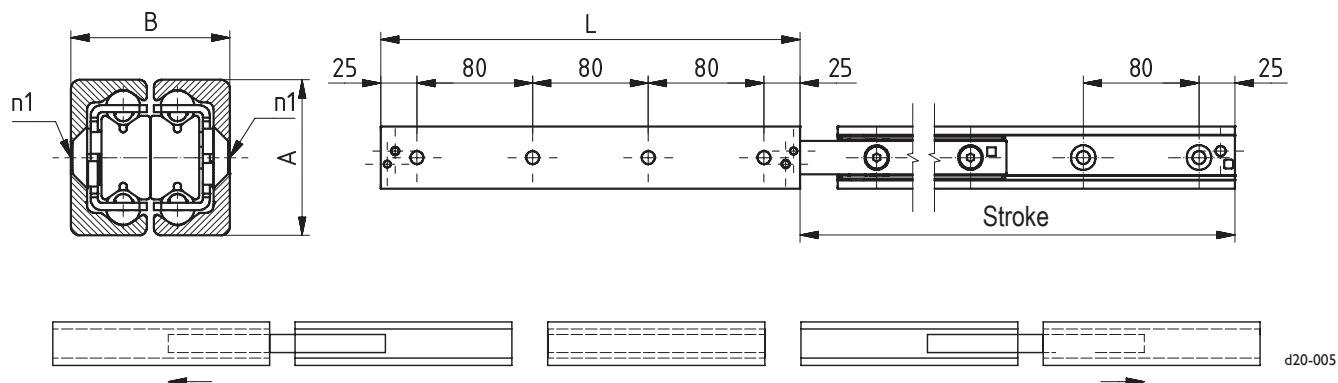

Designation	Stroke mm	Telescopic rail			Load ratings	
		L mm	no. of holes	weight kg	C_{0rad} N	C_{0ax} N
LCAD 43-0210	246	210	3	2.33	631	449
LCAD 43-0290	316	290	4	3.22	1,158	819
LCAD 43-0370	416	370	5	4.11	1,349	954
LCAD 43-0450	486	450	6	5.00	1,370	1,298
LCAD 43-0530	556	530	7	5.88	1,229	1,229
LCAD 43-0610	626	610	8	6.77	1,115	1,115
LCAD 43-0690	726	690	9	7.66	939	939
LCAD 43-0770	796	770	10	8.55	870	870
LCAD 43-0850	866	850	11	9.44	812	812
LCAD 43-0930	966	930	12	10.32	714	714
LCAD 43-1010	1,036	1,010	13	11.21	674	674
LCAD 43-1090	1,106	1,090	14	12.10	629	629
LCAD 43-1170	1,206	1,170	15	12.99	576	576
LCAD 43-1250	1,276	1,250	16	13.88	546	546
LCAD 43-1330	1,376	1,330	17	14.76	503	503
LCAD 43-1410	1,446	1,410	18	15.65	473	473
LCAD 43-1490	1,516	1,490	19	16.54	464	464
LCAD 43-1570	1,586	1,570	20	17.43	443	443
LCAD 43-1650	1,686	1,650	21	18.32	415	415
LCAD 43-1730	1,756	1,730	22	19.20	397	397
LCAD 43-1810	1,856	1,810	23	20.09	376	376
LCAD 43-1890	1,926	1,890	24	21.00	364	364
LCAD 43-1970	2,026	1,970	25	21.87	344	344

If the stop screws are removed, then the overall two-way stroke will be twice the stroke specified in this table.

Locking devices for the device in its extended and/or inserted state are available for this production series (single stroke) as standard.



7.3 LCAH 28H series – full extension (>100% stroke length) LCAH 35 series – full extension (>100% stroke length)

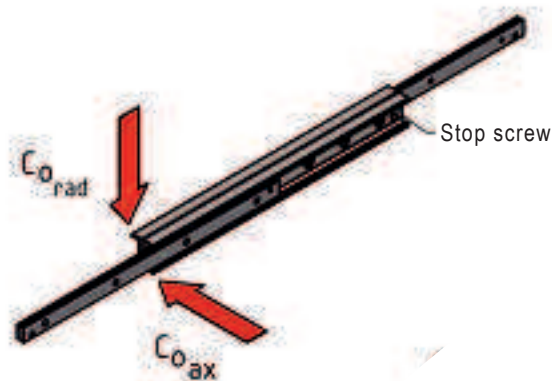

d20-003

Dimension	Profile size		
	28H	35	43
A	28	35	43
B	26	33	44
n1	Ø 5.5	Ø 6.5	Ø 8.5
n2	M5	M6	M8

Designation	Stroke mm	Telescopic rail			Load ratings	
		L mm	no. of holes	weight kg	$C_{o_{rad}}$ N	$C_{o_{ax}}$ N
LCAH 28H-0130	148	130	2	0.57	244	172
LCAH 28H-0210	232	210	3	0.92	447	314
LCAH 28H-0290	296	290	4	1.28	791	559
LCAH 28H-0370	380	370	5	1.63	1,001	499
LCAH 28H-0450	464	450	6	1.98	1,205	403
LCAH 28H-0530	548	530	7	2.33	1,140	351
LCAH 28H-0610	630	610	8	2.68	987	308
LCAH 28H-0690	714	690	9	3.04	869	270
LCAH 28H-0770	798	770	10	3.39	778	245
LCAH 28H-0850	864	850	11	3.74	734	236
LCAH 28H-0930	950	930	12	4.09	665	207
LCAH 28H-1010	1,034	1,010	13	4.44	610	191
LCAH 28H-1090	1,118	1,090	14	4.80	566	178
LCAH 28H-1170	1,202	1,170	15	5.15	523	164
LCAH 35-0210	254	210	3	1.20	409	286
LCAH 35-0290	318	290	4	1.65	811	570
LCAH 35-0370	406	370	5	2.10	1,038	731
LCAH 35-0450	494	450	6	2.60	1,265	811
LCAH 35-0530	558	530	7	3.05	1,706	749
LCAH 35-0610	646	610	8	3.60	1,932	647
LCAH 35-0690	734	690	9	3.95	1,720	574
LCAH 35-0770	798	770	10	4.50	1,629	541
LCAH 35-0850	886	850	11	4.95	1,459	489
LCAH 35-0930	974	930	12	5.35	1,322	445
LCAH 35-1010	1,038	1,010	13	5.85	1,263	427
LCAH 35-1090	1,126	1,090	14	6.30	1,159	394
LCAH 35-1170	1,214	1,170	15	6.75	1,069	361
LCAH 35-1250	1,278	1,250	16	7.20	1,029	348
LCAH 35-1330	1,366	1,330	17	7.65	959	325
LCAH 35-1410	1,454	1,410	18	8.15	899	308
LCAH 35-1490	1,518	1,490	19	8.70	870	287

If the stop screws are removed, then the overall two-way stroke will be twice the stroke specified. Carriage sliders with threaded holes, through-holes, or with a combination of both, are available for convenient fastening (see "Designation system" on page 30).

7.3 LCAH 43 series – full extension (>100% stroke length)

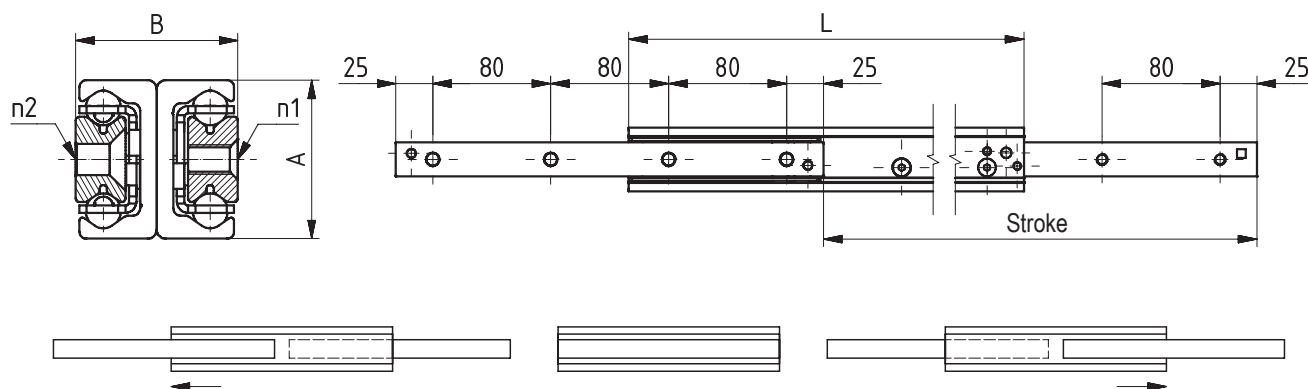

d20-007

Designation	Stroke mm	Telescopic rail			Load ratings	
		L mm	no. of holes	weight kg	C_{0rad} N	C_{0ax} N
LCAH 43-0210	246	210	3	2.21	631	451
LCAH 43-0290	316	290	4	3.05	1,159	805
LCAH 43-0370	416	370	5	3.89	1,349	957
LCAH 43-0450	486	450	6	4.73	1,894	1,338
LCAH 43-0530	556	530	7	5.57	2,460	1,539
LCAH 43-0610	626	610	8	6.41	3,037	1,398
LCAH 43-0690	726	690	9	7.25	3,197	1,191
LCAH 43-0770	796	770	10	8.09	3,146	1,112
LCAH 43-0850	866	850	11	8.93	2,932	1,031
LCAH 43-0930	966	930	12	9.77	2,581	905
LCAH 43-1010	1,036	1,010	13	10.61	2,435	847
LCAH 43-1090	1,106	1,090	14	11.45	2,293	799
LCAH 43-1170	1,206	1,170	15	12.29	2,083	728
LCAH 43-1250	1,276	1,250	16	13.13	1,986	695
LCAH 43-1330	1,376	1,330	17	13.97	1,819	642
LCAH 43-1410	1,446	1,410	18	15.81	1,755	601
LCAH 43-1490	1,516	1,490	19	15.65	1,677	582
LCAH 43-1570	1,586	1,570	20	16.49	1,648	546
LCAH 43-1650	1,686	1,650	21	17.33	1,502	522
LCAH 43-1730	1,756	1,730	22	18.17	1,456	513
LCAH 43-1810	1,856	1,810	23	19.01	1,360	473
LCAH 43-1890	1,926	1,890	24	19.85	1,318	461
LCAH 43-1970	2,026	1,970	25	20.69	1,242	430

If the stop screws are removed, then the overall two-way stroke will be twice the stroke specified. Carriage sliders with threaded holes, counter-sunk drill holes, or with a combination of both, are available for convenient fastening (see "Designation system" on page 30).

Product key suffix	Carriage slider fastening method
...GG	thread – thread
...DD	pass – pass
...GD	thread – pass



7.4 LCAS 35.E series – full extension (>100% stroke length)

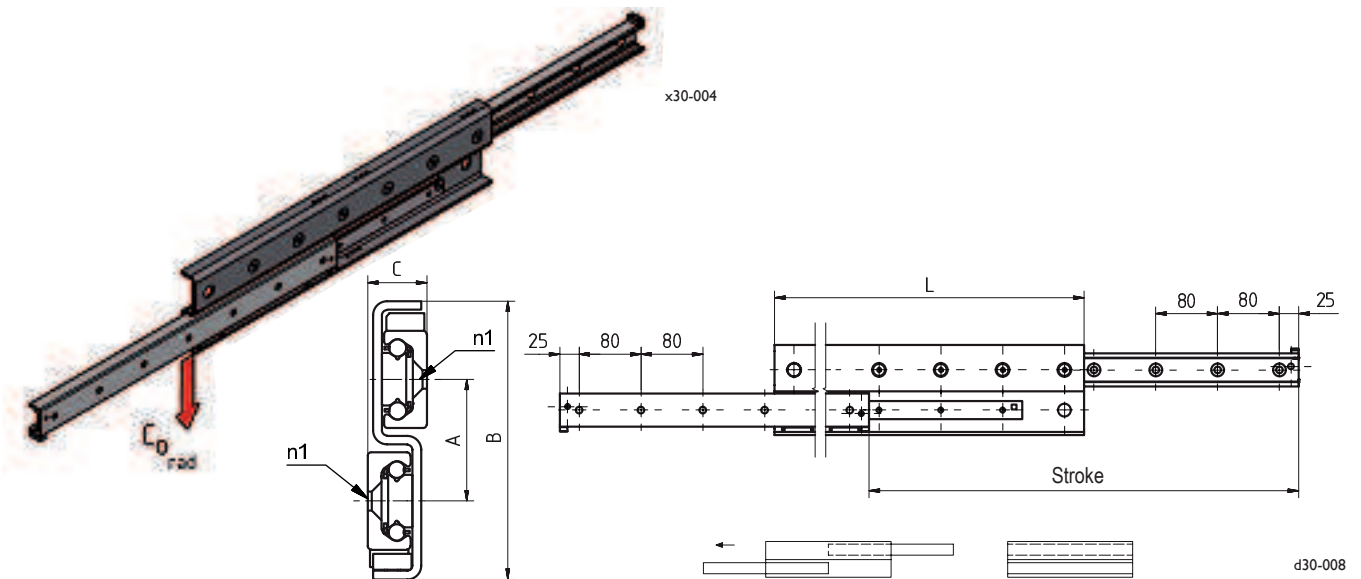

Designation	Stroke mm	Telescopic rail				Load ratings C_{0rad} N
		L mm	no. of holes	accessible holes	weight kg	
LCAS 28H.E-0290	296	290	4	3	2.52	587
LCAS 28H.E-0370	380	370	5	4	3.22	793
LCAS 28H.E-0450	464	450	6	4	3.91	999
LCAS 28H.E-0530	548	530	7	6	4.61	1,205
LCAS 28H.E-0610	630	610	8	6	5.30	1,514
LCAS 28H.E-0690	714	690	9	7	6.00	1,720
LCAS 28H.E-0770	798	770	10	7	6.69	1,926
LCAS 28H.E-0850	864	850	11	9	7.39	2,276
LCAS 28H.E-0930	950	930	12	9	8.08	2,307
LCAS 28H.E-1010	1,034	1,010	13	10	8.78	2,112
LCAS 28H.E-1090	1,118	1,090	14	10	9.47	1,959
LCAS 28H.E-1170	1,202	1,170	15	12	10.17	1,813
LCAS 28H.E-1250	1,266	1,250	16	12	10.86	1,749
LCAS 28H.E-1330	1,350	1,330	17	13	11.56	1,627
LCAS 28H.E-1410	1,434	1,410	18	13	12.25	1,531
LCAS 28H.E-1490	1,518	1,490	19	15	12.95	1,442

This production series allows for one-way pullout.

All telescopic guides are also available in a synchronised version, which ensures an even extension of the two movable segments. Locking devices can be supplied for an extended and/or inserted state for this production series.

You will find information on locking devices for an inserted state on page 28.

Dimension	Profile size			Variation with locking device for an extended state		
	28H	35	43	28H	35	43
A	35	43	52	50	60	72
B	80	97	117	86	105	122
C	17	22.5	28			
n1	Ø 5.5	Ø 5.5	Ø 8.5			

7.4 LCAS 28H.D series

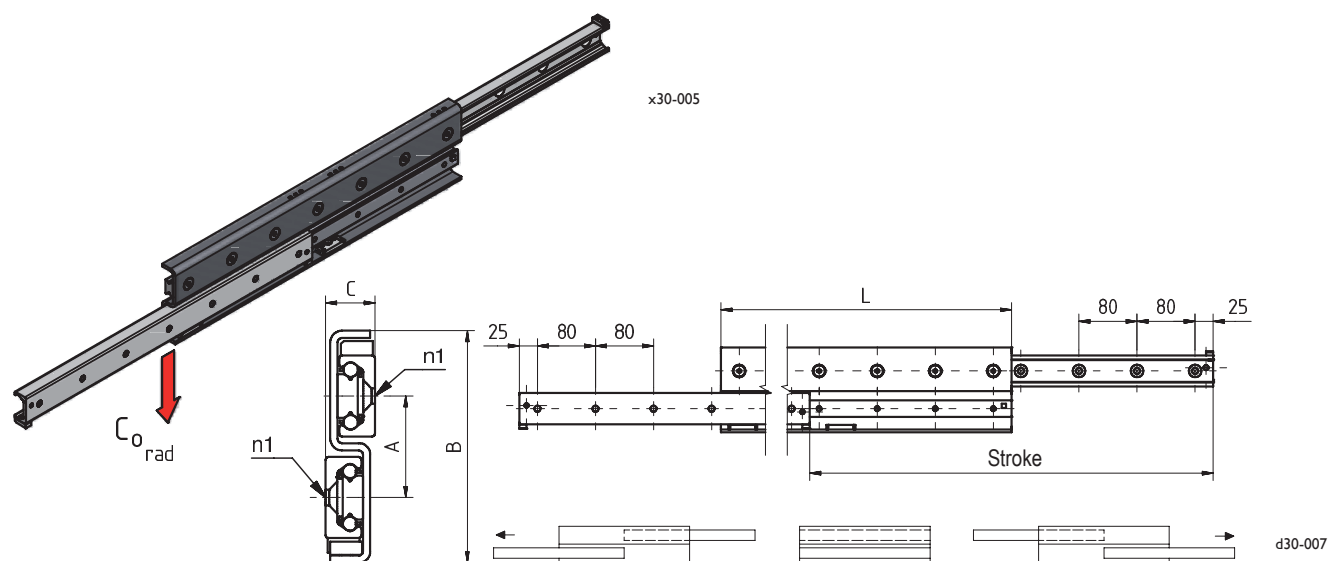

Designation	Stroke mm	Telescopic rail			Load ratings C_{0rad} N
		L mm	no. of holes	weight kg	
LCAS 28H.D-0290	246	290	4	2.52	1,061
LCAS 28H.D-0370	326	370	5	3.22	1,246
LCAS 28H.D-0450	406	450	6	3.91	1,576
LCAS 28H.D-0530	486	530	7	4.61	1,782
LCAS 28H.D-0610	566	610	8	5.30	1,998
LCAS 28H.D-0690	646	690	9	6.00	2,215
LCAS 28H.D-0770	726	770	10	6.69	2,431
LCAS 28H.D-0850	806	850	11	7.39	2,750
LCAS 28H.D-0930	886	930	12	8.08	2,791
LCAS 28H.D-1010	966	1,010	13	8.78	2,431
LCAS 28H.D-1090	1,046	1,090	14	9.48	2,251
LCAS 28H.D-1170	1,126	1,170	15	10.17	2,070
LCAS 28H.D-1250	1,206	1,250	16	10.86	1,943
LCAS 28H.D-1330	1,286	1,330	17	11.56	1,803
LCAS 28H.D-1410	1,366	1,410	18	12.25	1,699
LCAS 28H.D-1490	1,446	1,490	19	12.95	1,597

This type generally permits a two-way stroke.

On request, the V-shaped countersunk drill holes n1 can be executed as a cylindrical countersink. Please contact our technical department for further information on this issue.



7.4 LCAS 35.E series – full extension (>100% stroke length)

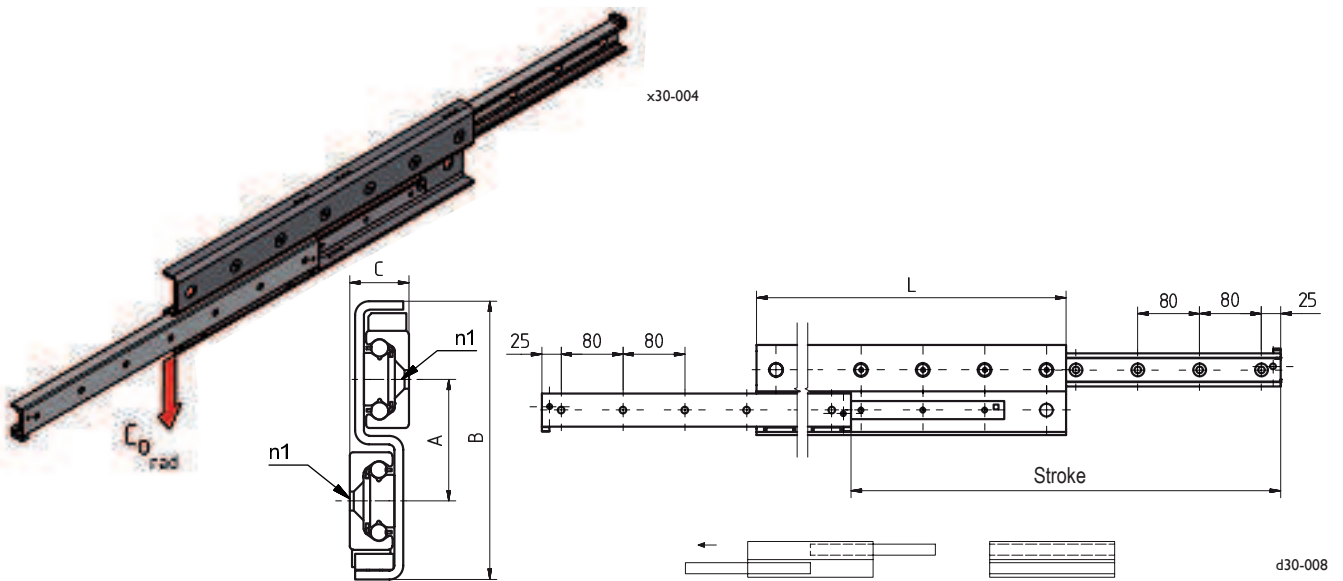

Designation	Stroke mm	Telescopic rail			weight kg	Load ratings C_{0rad} N
		L mm	no. of holes	accessible holes		
LCAS 35.E-0450	494	450	6	5	3.98	1,269
LCAS 35.E-0530	558	530	7	6	4.74	1,704
LCAS 35.E-0610	646	610	8	6	5.33	1,930
LCAS 35.E-0690	734	690	9	7	6.07	2,151
LCAS 35.E-0770	798	770	10	8	6.83	2,596
LCAS 35.E-0850	886	850	11	9	7.56	2,834
LCAS 35.E-0930	974	930	12	9	8.40	3,052
LCAS 35.E-1010	1,038	1,010	13	10	8.91	3,498
LCAS 35.E-1090	1,126	1,090	14	11	9.66	3,536
LCAS 35.E-1170	1,214	1,170	15	12	10.38	3,268
LCAS 35.E-1250	1,278	1,250	16	12	11.13	3,148
LCAS 35.E-1330	1,366	1,330	17	13	11.73	2,930
LCAS 35.E-1410	1,454	1,410	18	14	12.20	2,748
LCAS 35.E-1490	1,518	1,490	19	15	13.22	2,666
LCAS 35.E-1570	1,606	1,570	20	15	13.90	2,504
LCAS 35.E-1650	1,694	1,650	21	16	14.71	2,389
LCAS 35.E-1730	1,758	1,730	22	17	15.45	2,303

This production series allows for one-way pullout.

All telescopic guides are also available in a synchronised version, which ensures an even extension of the two movable segments. For this production series, locking devices can be supplied for an extended and/or inserted state as standard.

You will find information on locking devices for an inserted state on page 28.

Dimension	Profile size			Variation with locking device for an extended state		
	28H	35	43	28H	35	43
A	35	43	52	50	60	72
B	80	97	117	86	105	122
C	17	22.5	28			
n1	Ø 5.5	Ø 6.5	Ø 8.5			

7.4 LCAS 35.D series

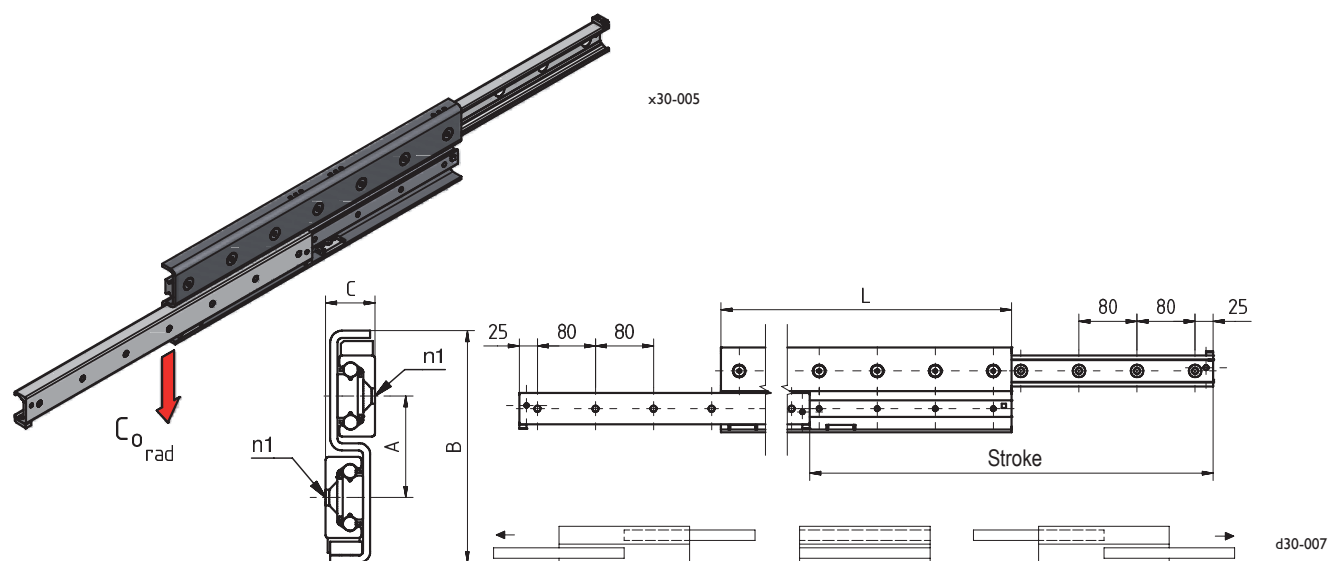

Designation	Stroke mm	Telescopic rail			Load ratings C_{0rad} N
		L mm	no. of holes	weight kg	
LCAS 35.D-0450	402	450	6	4.14	1,275
LCAS 35.D-0530	481	530	7	4.90	1,705
LCAS 35.D-0610	562	610	8	5.64	1,932
LCAS 35.D-0690	642	690	9	6.38	2,158
LCAS 35.D-0770	722	770	10	7.14	2,595
LCAS 35.D-0850	802	850	11	7.87	2,833
LCAS 35.D-0930	862	930	12	8.87	3,042
LCAS 35.D-1010	962	1,010	13	9.38	3,494
LCAS 35.D-1090	1,042	1,090	14	10.12	3,531
LCAS 35.D-1170	1,122	1,170	15	10.95	3,268
LCAS 35.D-1250	1,201	1,250	16	11.59	3,145
LCAS 35.D-1330	1,282	1,330	17	12.35	2,937
LCAS 35.D-1410	1,362	1,410	18	12.85	2,755
LCAS 35.D-1490	1,442	1,490	19	13.83	2,651
LCAS 35.D-1570	1,522	1,570	20	14.58	3,499
LCAS 35.D-1650	1,602	1,650	21	15.33	2,373
LCAS 35.D-1730	1,682	1,730	22	16.07	2,303

This type generally permits a two-way stroke.

On request, the V-shaped countersunk drill holes n1 can be executed as a cylindrical countersink.
Please contact our technical department for further information on this issue.



7.4 LCAS 43.E series – full extension (>100% stroke length)

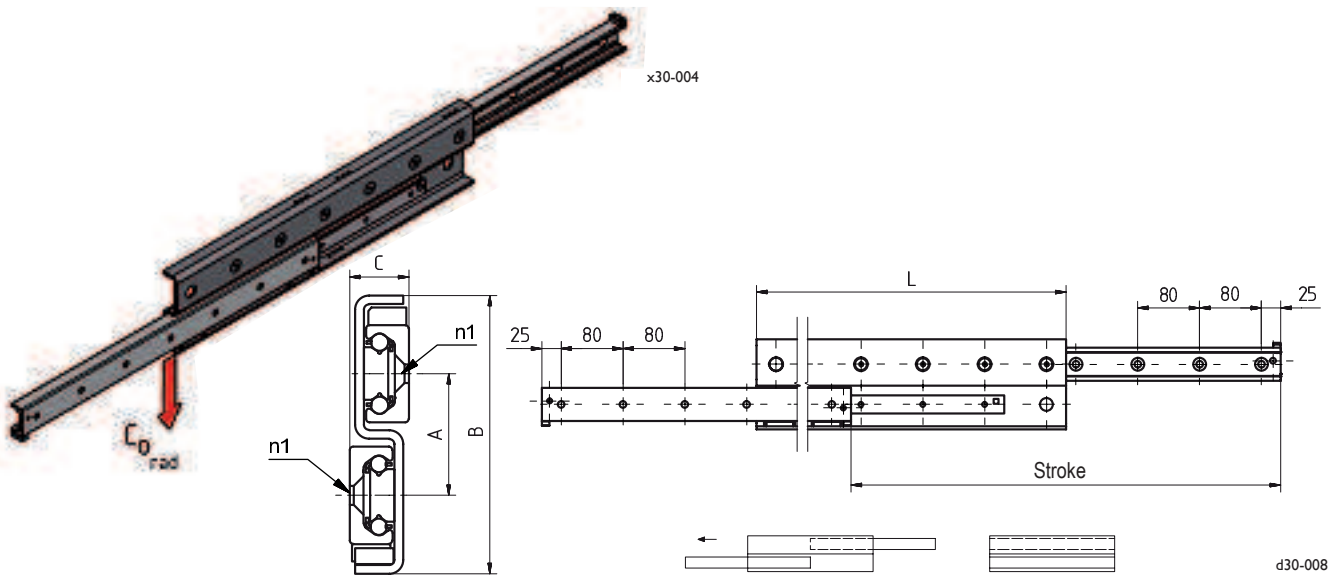

Designation	Stroke mm	Telescopic rail			Load ratings C _{0rad} N	
		L mm	no. of holes	accessible holes		weight kg
LCAS 43.E-0530	556	530	7	6	7.74	2,142
LCAS 43.E-0610	626	610	8	6	8.91	2,699
LCAS 43.E-0690	726	690	9	7	10.07	2,884
LCAS 43.E-0770	796	770	10	7	11.24	3,451
LCAS 43.E-0850	866	850	11	9	12.41	4,017
LCAS 43.E-0930	966	930	12	9	13.58	4,182
LCAS 43.E-1010	1,036	1,010	13	10	14.75	4,759
LCAS 43.E-1090	1,106	1,090	14	11	15.91	5,043
LCAS 43.E-1170	1,206	1,170	15	12	17.08	4,748
LCAS 43.E-1250	1,276	1,250	16	12	18.25	4,599
LCAS 43.E-1330	1,376	1,330	17	13	19.42	4,151
LCAS 43.E-1410	1,446	1,410	18	13	20.58	3,991
LCAS 43.E-1490	1,516	1,490	19	15	21.75	3,821
LCAS 43.E-1570	1,616	1,570	20	15	22.92	3,552
LCAS 43.E-1650	1,686	1,650	21	16	24.09	3,420
LCAS 43.E-1730	1,756	1,730	22	16	25.26	3,310
LCAS 43.E-1810	1,856	1,810	23	18	26.43	3,100
LCAS 43.E-1890	1,926	1,890	24	18	27.60	3,006
LCAS 43.E-1970	2,026	1,970	25	19	28.76	2,833

This production series allows for one-way pullout.

All telescopic guides are also available in a synchronised version, which ensures an even extension of the two movable segments. For this production series, locking devices can be supplied for an extended and/or inserted state as standard.

You will find information on locking devices for an inserted state on page 28.

Dimension	Profile size			Variation with locking device for an extended state		
	28H	35	43	28H	35	43
A	35	43	52	50	60	72
B	80	97	117	86	105	122
C	17	22.5	28			
n1	Ø 5.5	Ø 5.5	Ø 8.5			

7.4 LCAS 43.D series

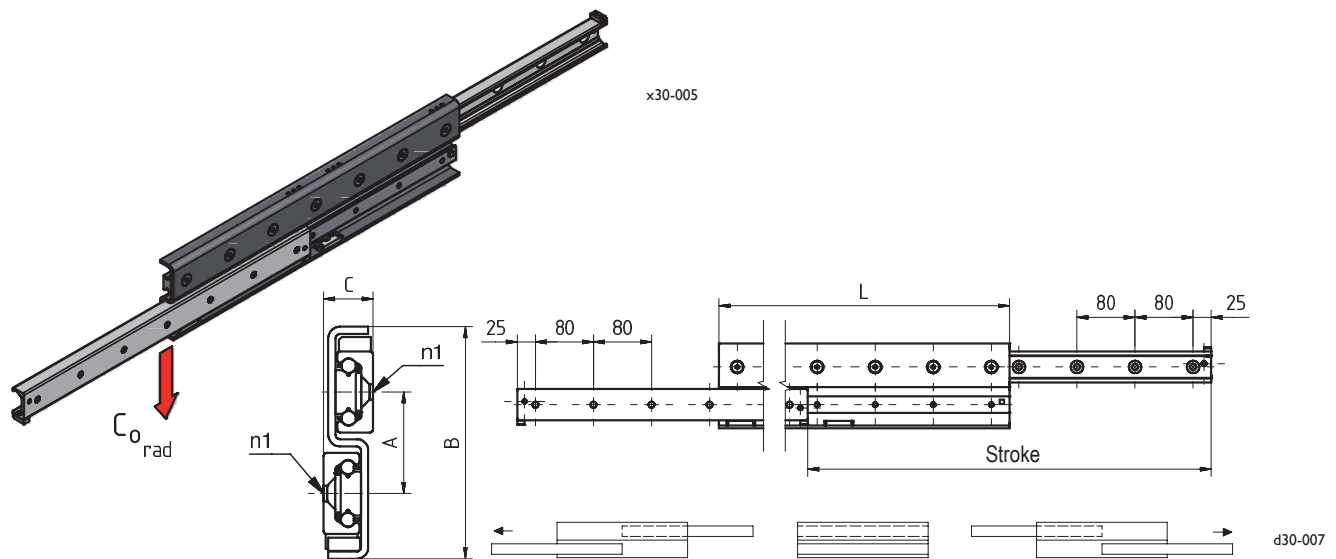

Designation	Stroke mm	Telescopic rail			Load ratings $C_{o_{rad}}$ N
		L mm	no. of holes	weight kg	
LCAS 43.D-0530	476	530	7	7.74	3,111
LCAS 43.D-0610	556	610	8	8.91	3,457
LCAS 43.D-0690	636	690	9	10.07	4,013
LCAS 43.D-0770	716	770	10	11.24	4,429
LCAS 43.D-0850	796	850	11	12.41	4,675
LCAS 43.D-0930	876	930	12	13.58	5,231
LCAS 43.D-1010	956	1,010	13	14.75	5,747
LCAS 43.D-1090	1,036	1,090	14	15.91	5,968
LCAS 43.D-1170	1,116	1,170	15	17.08	5,552
LCAS 43.D-1250	1,196	1,250	16	18.25	5,133
LCAS 43.D-1330	1,276	1,330	17	19.42	4,831
LCAS 43.D-1410	1,356	1,410	18	20.58	4,519
LCAS 43.D-1490	1,436	1,490	19	21.75	4,264
LCAS 43.D-1570	1,516	1,570	20	22.92	4,037
LCAS 43.D-1650	1,596	1,650	21	24.09	3,821
LCAS 43.D-1730	1,676	1,730	22	25.26	3,651
LCAS 43.D-1810	1,756	1,810	23	26.43	3,461
LCAS 43.D-1890	1,836	1,890	24	27.60	3,333
LCAS 43.D-1970	1,916	1,970	25	28.76	3,172

This type generally permits a two-way stroke.

On request, the V-shaped countersunk drill holes n1 can be executed as a cylindrical countersink. Please contact our technical department for further information on this issue.



7.5 LCBS 28H.E series – full extension with track rollers

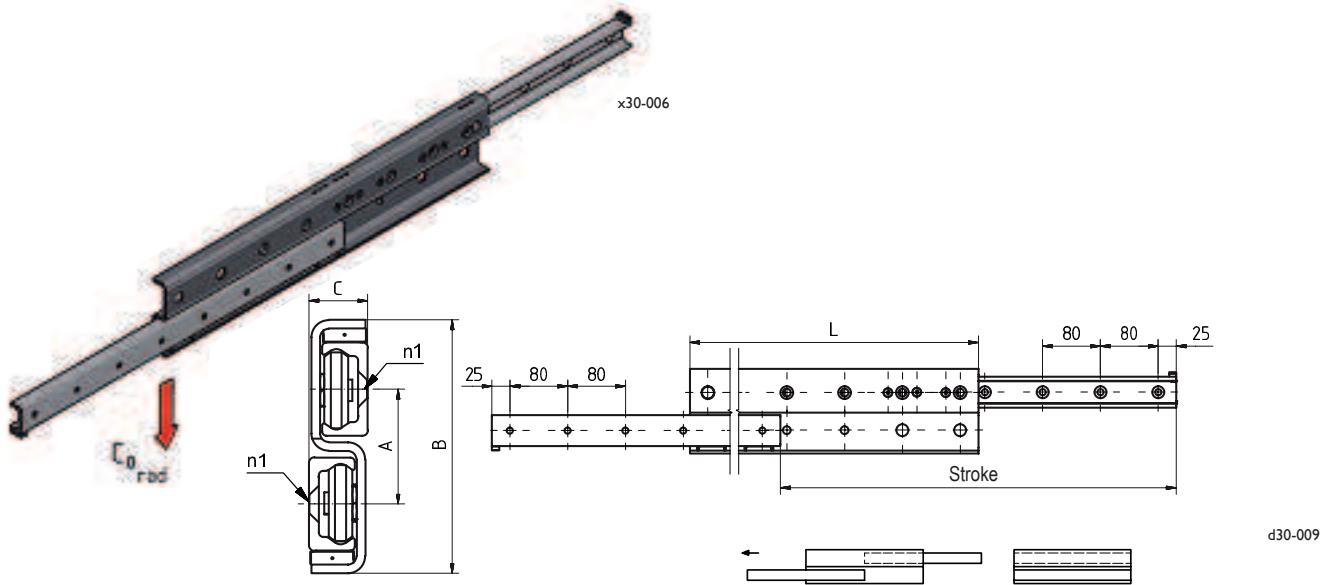

Designation	Stroke mm	Telescopic rail			weight kg	Load ratings C_{0rad} N
		L mm	no. of holes	accessible holes		
LCBS 28H.E-0290	296	290	4	3	1.58	1,073
LCBS 28H.E-0370	380	370	5	4	1.95	1,141
LCBS 28H.E-0450	464	450	6	4	2.33	1,213
LCBS 28H.E-0530	548	530	7	6	2.71	1,269
LCBS 28H.E-0610	630	610	8	6	3.09	1,307
LCBS 28H.E-0690	714	690	9	7	3.47	1,372
LCBS 28H.E-0770	798	770	10	7	3.85	1,433
LCBS 28H.E-0850	864	850	11	9	4.22	1,514
LCBS 28H.E-0930	950	930	12	9	4.60	1,568
LCBS 28H.E-1010	1,034	1,010	13	10	4.98	1,613
LCBS 28H.E-1090	1,118	1,090	14	10	5.36	1,666
LCBS 28H.E-1170	1,202	1,170	15	12	5.74	1,711
LCBS 28H.E-1250	1,266	1,250	16	12	6.12	1,730
LCBS 28H.E-1330	1,350	1,330	17	13	6.49	1,767
LCBS 28H.E-1410	1,434	1,410	18	13	6.92	1,782
LCBS 28H.E-1490	1,518	1,490	19	15	7.25	1,815

All telescopic guides are also available in a synchronised version, which ensures an even extension of the two movable segments. This will prevent any “sliding” of the cage, which is theoretically possible. You will find information on the overall heights A and B in the data for the LCAS production series (on page 20).

Dimension	Profile size		
	28H	35	43
A	35	43	52
B	80	97	117
C	17	22.5	28
n1	Ø 5.5	Ø 5.5	Ø 8.5

7.5 LCBS 43.E series – full extension with track rollers

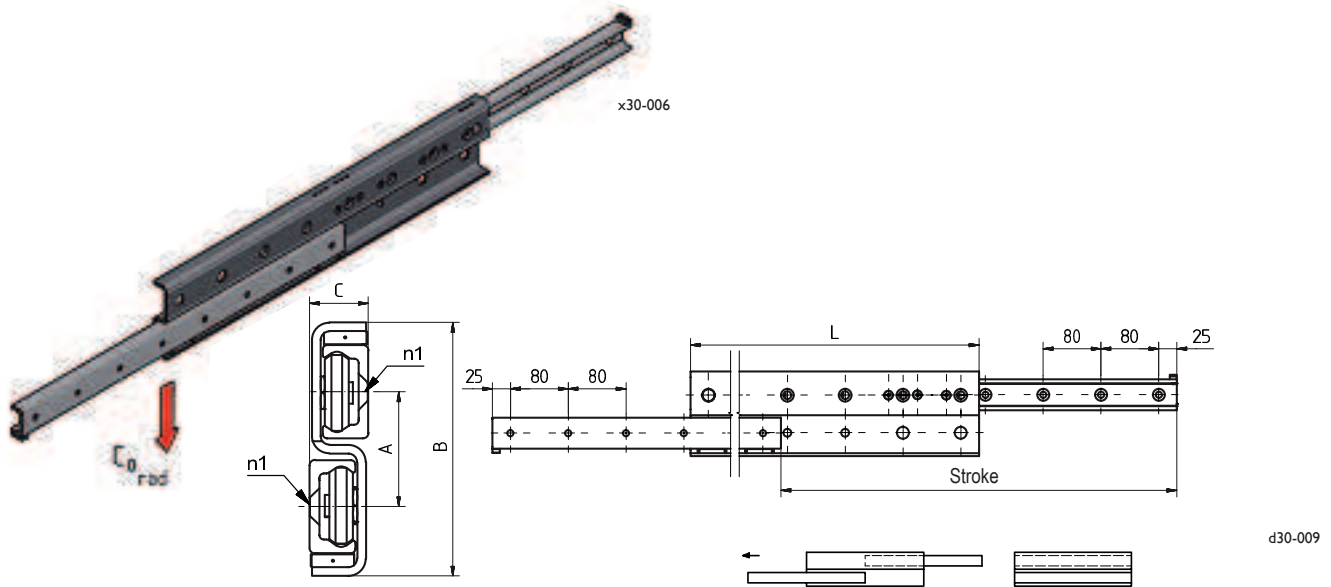

Designation	Stroke mm	Telescopic rail			weight kg	Load ratings $C_{O_{rad}}$ N
		L mm	no. of holes	accessible holes		
LCBS 43.E-0530	556	530	7	6	6.0	2,098
LCBS 43.E-0610	626	610	8	8	6.9	2,213
LCBS 43.E-0690	726	690	9	8	7.8	2,314
LCBS 43.E-0770	796	770	10	10	8.7	2,397
LCBS 43.E-0850	866	850	11	10	9.6	2,473
LCBS 43.E-0930	966	930	12	12	10.5	2,534
LCBS 43.E-1010	1,036	1,010	13	12	11.3	2,590
LCBS 43.E-1090	1,116	1,090	14	14	12.2	2,633
LCBS 43.E-1170	1,206	1,170	15	14	13.1	2,674
LCBS 43.E-1250	1,286	1,250	16	16	14.0	2,705
LCBS 43.E-1330	1,376	1,330	17	16	15.0	2,735
LCBS 43.E-1410	1,446	1,410	18	18	15.9	2,760
LCBS 43.E-1490	1,516	1,490	19	18	16.7	2,785
LCBS 43.E-1570	1,596	1,570	20	20	17.6	2,797
LCBS 43.E-1650	1,686	1,650	21	20	18.5	2,825
LCBS 43.E-1730	1,766	1,730	22	22	19.4	2,830
LCBS 43.E-1810	1,856	1,810	23	22	20.3	2,846
LCBS 43.E-1890	1,936	1,890	24	24	21.2	2,858
LCBS 43.E-1970	2,026	1,970	25	24	22.2	2,875

All telescopic guides are also available in a synchronised version, which ensures an even extension of the two movable segments. This will prevent any “sliding” of the cage, which is theoretically possible. You will find information on the overall heights A and B in the data for the LCAS production series (on page 24).



7.6. Locking devices

7.7 End position dampings

7.6. Locking devices

Locking devices can only be used with telescopic guides that have a one-way stroke.

Locking devices for an inserted state

We can supply locking devices for an **inserted** state for the LCAS and LCBS production series. The typical locking device is shown on this page. The measure H is the additional length that is added to the relevant standard length. The force $F_{zul.}$ is the permissible tensile force in the direction of extension.

Please note: locking devices come in right and left variations.

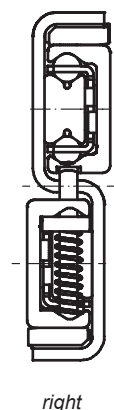
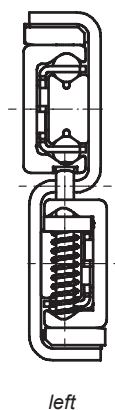
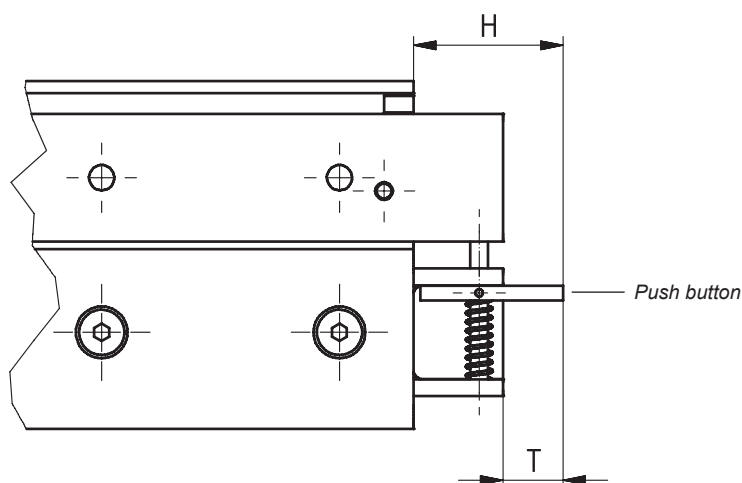

x30-010

Profile size	H	T	$F_{zul.}$
	mm	mm	N
28 H	30	10	2,450
35	40	15	3,800
43	50	20.25	5,650

The product key will contain the relevant suffix: ... VL for the left side and ... VR for the right side (see page 31).

Locking devices for an extended state

Additionally, we can supply catches or locking devices for an **extended** state and various intermediate conditions. This will lead to a change in overall height. You will find the measurements in the tables on pages 20, 22, 24 and 26.

7.7 End position dampings

End position dampings with different features are available for all production series. Please contact our technical department for further information on this issue.

8. IBC Linear Guides with ATCoat Coating



Fig. 8.1: LCE Telescopic-Runner with ATCoat coating

8. ATCoat coated linear motion bearings and telescopic guides

The material surface of machine parts is becoming more and more important to the overall performance of machines, power units and equipment. However, outside influences very often alter the surface quality of materials or corrode the surface material.

An ATCoat thin dense chromium coating protects the surface from outside environmental conditions and thereby increases the service life of linear guides and telescopic pullouts.

The advantages of this coating also include energy saving and an efficient use of material.

The ATCoat coating consists of 98% pure chrome. The chromium coating is extremely hard (between 75 and 78 HRC), free of cracks, firmly adhering, cone-shaped, precise, very thin, and highly pure (see fig. 8.2).

Because the process temperature during coating is below 80 °C there is no structural change to the basic material. The ATCoat coating is free of cracks and cone-shaped; this makes it much more resistant to corrosion than normal chromium coating.

Chrome also has very low wettability, a characteristic that enables it to repel aqueous media from its surface, enhancing resistance to corrosion even further.

The ideal coating thickness is between 2 µm to 4 µm thick, depending on the requirements of the components that are at risk of corrosion or abrasion. The holes of the profile rails are coated in a tapering manner in this case.

The ATCoat coating provides very good protection against corrosion and wear and results in good rolling capacity. You will find further information in our brochure **IBC Rolling Bearings With ATCoat Coating TI-I-5011**.

An ATCoat coating is very often applied to linear guides and telescopic runners in the food and chemical industries, where the typical industrial application exposes the machine parts concerned to corrosive or aggressive media, and where machine parts made of stainless steel do not offer the required permissible load or permissible load rating.

Because the ATCoat coating has received USDA approval and has been approved in accordance with EU Regulation No. 1935/2004, it may also be used in the food industry.



Fig. 8.2: Cross section of the ATCoat coating

9. Designation System

LCAD and LCAE production series

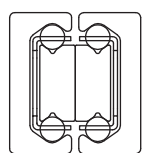
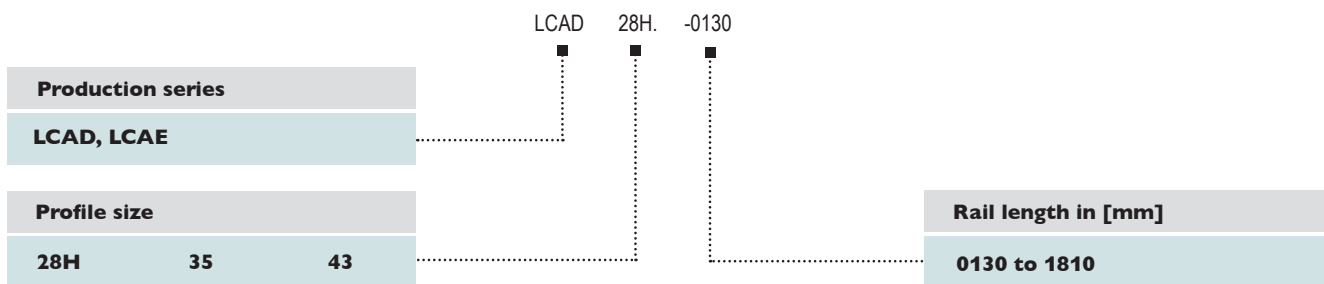

LCAD



71-010

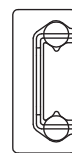

LCAE



71-009

LCAH production series

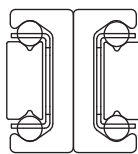
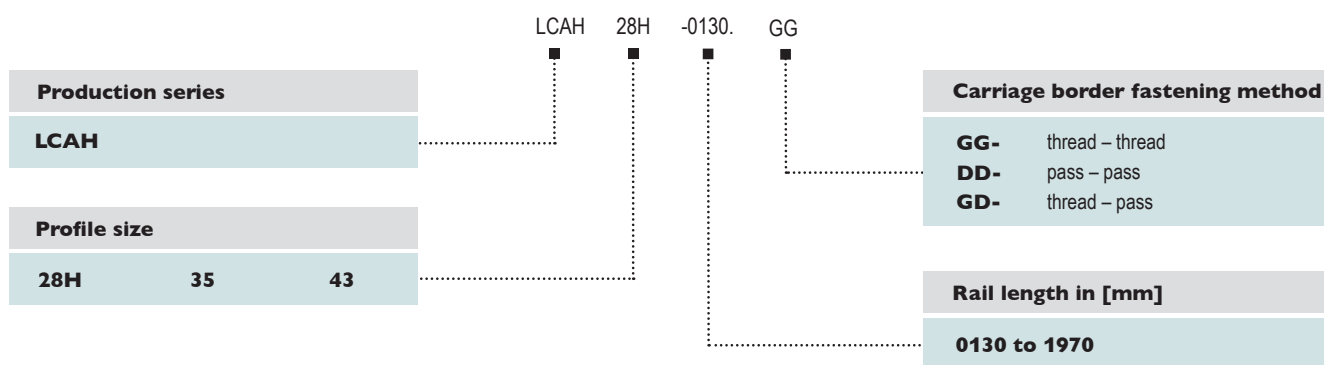

LCAH



71-011

LCAS and LCBS production series

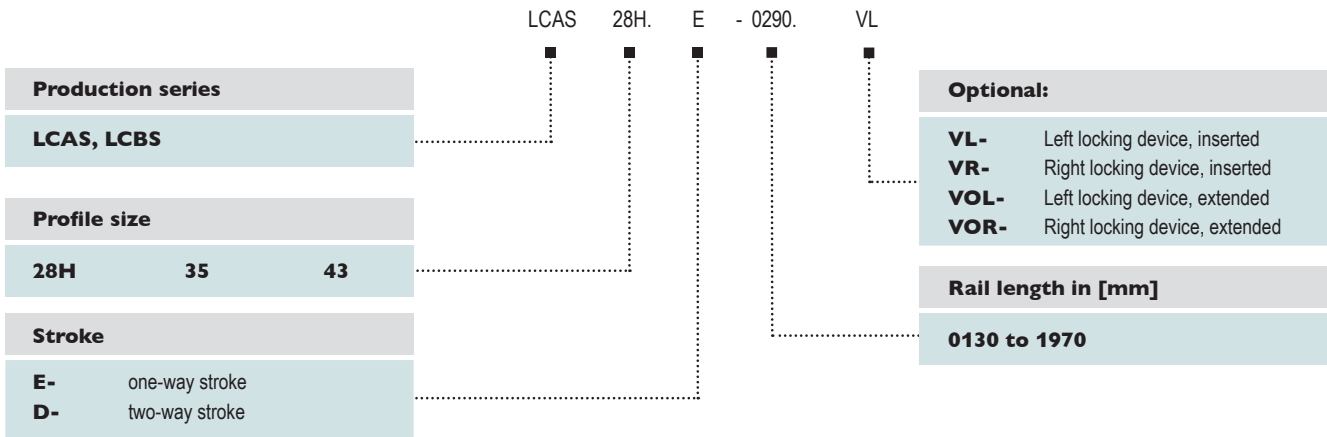

LCAS



71-013



LCBS

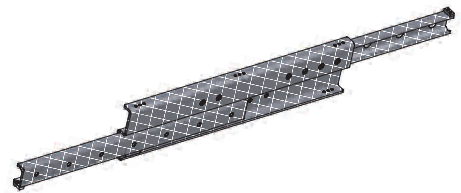

d30-010

IBC Telescopic-Runners with ATCoat coating are designated with an "AC" prefix, e.g. "AC-LCE ...".
 Electroless nickel plating has a "ChNi" suffix after the product key, e.g. LCAS 28H.E-0290.ChNi.
 With regard to the product key for synchronised versions or locking devices for an extended condition, or combinations thereof, please contact us for more information.

Reproducing this catalogue (including reproduction in extracts) is only permitted with our consent. The information contained in this publication has been compiled with the greatest care. We cannot assume liability with regard to possible mistakes or missing information, however; we also cannot assume liability for damage that may occur directly or indirectly due to the use of the information contained herein. We reserve the right to implement changes that are conducive to progress (further development). © Copyright 2013 IBC