



K SERIES

Kegelstirnradtriebmotoren

Helical Bevel Geared Motors

Motoriduttori Ortogonali

Motoréducteurs Orthogonaux

Motorreductores Ortogonales

techno@drive.pro



Eine Änderung in diesem Katalog der Technischen Werte sowie Daten und Maßen und Gewichte bleiben vorbehalten. /

We reserve the right to our company to make changes or modifications to catalogue without prior notice. /

Nous réservons le droit à notre société d'apporter toutes sortes de changement ou modifications au catalogue sans préavis. /

Ci riserviamo il diritto di apportare cambiamenti o modifiche al catalogo senza preavviso. /

Nuestra compañía se reserva el derecho a realizar cambios o modificaciones a este catálogo sin previo aviso. /

NRW[®]
DRIVE TECHNOLOGIES

technositive.pro



techno@drive.pro

Zeichen / Symbols / Simbologia / Symboles / Simbologia	3
Technische Informationen / Technical Information / Informazioni Tecniche / Informacion Tecnica / Información Técnico	4 - 7
Betriebsfaktor / Service factor / Fattore di servizio / Facteur de service / Factor de servicio	8 - 9
Kritische Anwendungen / Critical applications / Applicazioni critiche / Applications critiques / Aplicaciones Críticas	10 - 11
Thermische Leistung / Thermal Power / Potenza termica / Puissance thermique / Potencia térmica	12 - 15
Montage des Motors an den PAM - Flansch B5 / Motor mounting with PAM flange B5 / Montaggio motore su flange B5 / Installation moteur sur bride PAM B5 / Montaje de motores con brida B5	16
IEC-PAM Buchse / IEC-PAM Sleeve / Manicotto IEC-PAM / Manchon IEC-PAM / Manguito IEC-PAM	17
Montage / Installation / Installazione / Installation / Instalación	18 - 19
Querbelastungen / Radial loads / Carichi radiali / Charges radiales / Cargas radiales	20 - 22
Massenträgheitsmomente / Moments of inertia / Momenti d'inerzia / Moments d'inertie / Momentos de inercia	23
Schmierung / Lubrication / Lubrificazione / Lubrification / Lubricación	24 - 26
Einbaulage / Mounting positions / Piazzamento / Pos. de montage / Pos. de montaje	27- 30
Modulares Baukastensystem / Modularity / Modularità / Modularité / Modularidad	31
Produkte / Products / Prodotti / Produits / Productos	32 - 34
Formular für getriebeauswahl / Gearbox selection form / Modulo di selezione riduttore / Formulaire de sélection de réducteurs / Formulario de selección del reductor	35 - 39
Beispiel Bestellbeschreibung / Example for ordering / Esempio di ordinazione / Exemple de commande / Ejemplo orden de compra	40
Bezeichnung / Designation / Designazione / Désignation / Designación	41
Nomenklatur / Nomenclature / I termini usati / Les termes utilisés / Los términos utilizados	42
Zubehör / Accessories / Accessori / Accessoires / Accesorios	43 - 49
Auswahltable von Getriebemotoren / Selection Tables of Gearedmotors / Tabella di selezione di motoriduttori / Tableau de sélection du motoreducteurs / Tabla de selección de motorreductores	50 - 92
Maßtabellen / Dimension Tables / Maßtabellen / Tables de Dimension / Tablas de Dimensiones	93 - 107
Auswahltable von W - PAM - IEC Adapters / Selection Tables of W - IEC and PAM Adapters / Tabella di selezione di W - PAM - IEC Adattatore / Tableau de sélection du W - PAM - IEC Adaptateur / Tabla de selección de W - PAM - IEC Adaptador	109 - 117
Allgemeine Teileliste / General Part List / Generale Elenco Delle Parti / Générale la liste des pièces / Lista de Piezas en General	118 - 128
Elektromotoren / Electric Motors / Motori elettrici / Moteurs électriques / Motores eléctricos	129 - 158
Ersatzteilliste Für Motor / Motor Part List / Elenco Parti Motore / Liste Des Pièces Du Moteur / Lista De Piezas Del Motor	159 - 162
Bremse-Teileliste / Brake parts list / Elenco delle parti freno / Liste des pièces de frein / Lista de piezas de freno	163



technoohdrive.pro

DE ZEICHEN

EN SYMBOLS

IT SIMBOLOGIA

FR SYMBOLES

ES SIMBOLOGIA

Zeichen

P = Leistung in	(kW)	1 = Antriebswelle
M = Drehmoment in	(Nm)	2 = Abtriebswelle
n = Drehzahl in	(rpm)	R = Radial
i = Übersetzung		A = Axial
F = Kraft in	(N)	s = Statisch
m = Masse in	(kg)	d = Dynamisch
f_B = Betriebsfaktor		max = Maximal
		min = Minimal

Symbols

P = Power	(kW)	1 = Input shaft
M = Torque	(Nm)	2 = Output shaft
n = Speed	(rpm)	R = Radial
i = Reduction ratio		A = Axial
F = Load	(N)	s = Static
m = Weight	(kg)	d = Dynamic
f_B = Service factor		max = Maximum
		min = Minimum

Simbologia

P = Potenza	(kW)	1 = Albero ingresso
M = Momento torcente	(Nm)	2 = Albero uscita
n = Numero giri	(giri / 1')	R = Radiale
i = Rapporto di riduzione		A = Assiale
F = Forza	(N)	s = Statico
m = Peso	(kg)	d = Dinamico
f_B = Fattore di servizio		max = Massimo
		min = Minimo

Symboles

P = Puissance	(kW)	1 = Arbre d'entrée
M = Moment de torsion	(Nm)	2 = Arbre de sortie
n = Nombre de tours	(tours/min)	R = Radial
i = Rapport de réduction		A = Axial
F = Force	(N)	s = Statique
m = Poids	(kg)	d = Dynamique
f_B = Facteur de service		max = Maximum
		min = Minimum

Simbologia

P = Potencia	(kW)	1 = Eje de entrada
M = Momento torsor	(Nm)	2 = Eje de salida
n = Número de revoluciones	(rpm)	R = Radial
i = Relación de reducción		A = Axial
F = Fuerza	(N)	s = Estático
m = Peso	(kg)	d = Dinámico
f_B = Factor de servicio		max = Máximo
		min = Mínimo

DE TECHNISCHE INFORMATIONEN

Für die korrekte Auswahl eines Getriebes oder eines Getriebemotors müssen einige grundsätzliche Daten bekannt sein:

A. Die Antriebsdrehzahl am Getriebeeingang (n_1) und die gewünschte Abtriebsdrehzahl (n_2).
Mit diesen beiden Werten kann das Übersetzungsverhältnis (i) des Getriebes mit der folgenden Formel ausgerechnet werden:

$$i = \frac{n_1}{n_2}$$

B. Das für die Anwendung erforderte Drehmoment (M_H)
Wenn diese Daten bekannt sind, kann mit der Auswahl des Getriebemotors oder des Getriebes fortgefahren werden.

Auswahl der Getriebemotoren

Dieser Ratgeber führt in wenigen Schritten durch die Auswahl des geeigneten Antriebes:

1. Den Betriebsfaktor (f_b) der Anwendung bestimmen Dieser Parameter ist eine Funktion aus der Belastungsart der angetriebenen Maschine, der Anzahl der Anläufe pro Stunde und der Betriebsstundenzahl (siehe Absatz "Betriebsfaktor" S. 8-9)
2. Die Eingangsleistung P_H über das erforderliche Drehmoment M_H , die Abtriebsdrehzahl n_2 und den dynamischen Wirkungsgrads ermitteln.
Der Wert des dynamischen Wirkungsgrads hängt von der Art des Getriebes und von der Anzahl der Übersetzungsstufen ab. Für die Kegelstirnradgetriebe der Serie K gilt ein mittlerer Wert von: $0,9 (\eta_d)$
 $K..3$ Übersetzungsstufen = $0,9$

$$P_H = \frac{M_H \cdot n_2}{9550 \cdot \eta_d}$$

3. Eine genormte Leistung P_1 aus der Tabelle der Getriebemotorenleistungen aussuchen, die höher ist als die erforderliche P_H , sodass:

$$P_1 \geq P_H$$

4. Nach dem Ermitteln der geeigneten genormten Leistung den Getriebemotor auswählen, der die Abtriebsdrehzahl zur Verfügung stellt, die der gewünschten n_2 am nächsten kommt, und der einen gleich hohen oder größeren Betriebsfaktor f_b besitzt als durch die Anwendung gefordert.

In den Auswahltabellen der Getriebemotoren sind die Kombinationen mit 50Hz - Motoren mit 2, 4 oder 6 Polen dargestellt. Für abweichende Antriebsgeschwindigkeiten berücksichtigen Sie bitte die Daten aus den Getriebetabellen.

EN TECHNICAL INFORMATION

For correctly selecting a gear reducer or geared motor, several essential pieces of data are required:

A. The rotational input speed to the gear reducer (n_1) and the rotational output speed (n_2).
Through these two values it is possible to calculate the reduction ratio (i) of the gear reducer using the following formula:

$$i = \frac{n_1}{n_2}$$

B. The torque required by the application (M_H)
The geared motor or gear reducer can be selected once this data is known.

Geared motor selection

This guide indicates a brief sequence of steps for selecting a suitable product:

1. Determine the application's actual service factor (f_b)
This parameter depends on the type of load of the powered machine, the number of starts per hour and the hours of operation (refer to the "Service factor" paragraph on page 8-9)
2. Calculate the input power P_H using the required torque value M_H , the speed n_2 and dynamic efficiency value.
The dynamic efficiency value depends on the type of gear reducer and on the number of gear reduction stages. K - range helical bevel gear reducers have an average value equal to: (η_d)
 $K..3$ stages = $0,9$

$$P_H = \frac{M_H \cdot n_2}{9550 \cdot \eta_d}$$

3. Consult the geared motor performance tables and identify a normalised power value P_1 exceeding the required power P_H , such that:

$$P_1 \geq P_H$$

4. Once the suitable normalised power has been identified, select the geared motor capable of generating the rotational speed closest to the desired n_2 value and with service factor f_b greater or equal to that required by the application.

In the geared motor selection tables the combinations include 2-pole, 4-pole and 6-pole motors powered at 50Hz; for different drive speeds refer to the nominal data provided for the gear reducers.

IT INFORMAZIONI TECNICHE

Per la corretta selezione di un riduttore o di un motoriduttore occorre disporre de alcuni dati fondamentali quali:

A. La velocità angolare in entrata al riduttore (n_1) e la velocità angolare in uscita (n_2).
Attraverso questi due valori è possibile calcolare il rapporto di riduzione (i) del riduttore attraverso la formula:

$$i = \frac{n_1}{n_2}$$

B. Il momento torcente richiesto dall'applicazione (M_H).
Noti questi dati, si può procedere nella selezione del motoriduttore o del riduttore.

Selezione dei motoriduttori

Questa guida conduce alla selezione del prodotto attraverso pochi passi:

1. Determinare il fattore di servizio effettivo dell'applicazione (f_b). Questo parametro è funzione del tipo di carico della macchina azionata, del numero di azionamenti per ora e del numero di ore di funzionamento (vedi paragrafo "Fattore di servizio" pag. 8-9).
2. Ricavare la potenza in entrata P_H mediante il momento torcente richiesto M_H , la velocità n_2 e il rendimento dinamico.
Il valore di rendimento dinamico dipende dalla tipologia del riduttore e dal numero di stadi d'ingranaggi di riduzione. I riduttori ortogonali della serie K presentano unvalore medio pari a:
 (η_d) $K..3$ stadi = $0,9$

$$P_H = \frac{M_H \cdot n_2}{9550 \cdot \eta_d}$$

3. Consultare le tabelle delle prestazioni dei motoriduttori ricercando una potenza normalizzata P_1 superiore a quella richiesta P_H tale che:

$$P_1 \geq P_H$$

4. Individuata la potenza normalizzata idonea, selezionare dunque il motoriduttore in grado di sviluppare lavelocità angolare più vicina a quella n_2 desiderata e con fattore di servizio f_b maggiore o uguale richiesto dall'applicazione.

Nelle tabelle di selezione dei motoriduttori gli abbinamenti sono realizzati con motori 2,4,6 poli alimentati a 50Hz, per velocità di azionamento diverse riferirsi ai dati nominali forniti per i riduttori.

FR

INFORMACION TECNICA

Pour choisir correctement un réducteur ou un motorréducteur, il est nécessaire de disposer de certaines données fondamentales telles que:

A. La vitesse angulaire en entrée du réducteur (n_1) et la vitesse angulaire en sortie (n_2).

Grâce à ces deux valeurs, il est possible de calculer le rapport de réduction (i) du réducteur en utilisant la formule:

$$i = \frac{n_1}{n_2}$$

B. Le moment de torsion requis par l'application (M_H)
Une fois ces données, il est possible de procéder au choix du motorréducteur ou du réducteur.

Selection des motorréducteur

Ce guide permet de procéder à la sélection du produit en suivant quelques étapes:

1. Déterminer le facteur de service effectif de l'application (f_b). Ce paramètre dépend du nombre d'actionnements par heure et du nombre d'heures de fonctionnement (voir paragraphe "Facteur de service" page 8-9).

2. Déterminer la puissance en entrée P_H à l'aide du moment de torsion requis M_H de la vitesse n_2 et du rendement dynamique.

La valeur du rendement dynamique dépend du type de réducteur et du nombre de trains d'engrenages de réduction. Les réducteurs orthogonaux de la série K présentent une valeur moyenne égale à: (η_d)
K..3 trains = 0,9

$$P_H = \frac{M_H \cdot n_2}{9550 \cdot \eta_d}$$

3. Consulter le tableau des performances des motorréducteurs en recherchant une puissance normalisée P_1 supérieure à la puissance P_H demandée telle que:

$$P_1 \geq P_H$$

4. Une fois identifiée la puissance normalisée adéquate, sélectionner le motoréducteur en mesure de développer la vitesse angulaire la plus proche de la vitesse n_2 désirée et présentant un facteur de service f_b supérieur ou égal à celui demandé par l'application.

Dans les tableaux de sélection des motoréducteurs, les combinaisons sont réalisées avec des moteurs 2,4,6 pôles alimentés à 50Hz. Pour des vitesses d'actionnement différentes, se référer aux données nominales fournis par les réducteurs

ES

INFORMACIÓN TÉCNICO

Para la correcta selección de un reductor o de un motorreductor es necesario disponer de algunos datos fundamentales como:

A. La velocidad angular a la entrada del reductor (n_1) y la velocidad angular a la salida (n_2). A través de reducción (i) del reductor utilizando la fórmula:

$$i = \frac{n_1}{n_2}$$

B. El momento de torsión requerido por la aplicación (M_H).
Conocidos estos datos, se puede proceder a la selección del motorreductor o del reductor.

Selección de los motorreductores

Esta guía conduce a la selección del producto a través de unos pocos pasos:

1. Determinar el factor de servicio efectivo de la aplicación (f_b). Este parámetro es función del tipo de carga de la máquina accionada, del número de accionamientos por hora y de la cantidad de horas de funcionamiento (ver el párrafo "Factor de servicio" pág. 8-9)

2. Obtener la potencia a la entrada P_H utilizando el momento de torsión requerido M_H , la velocidad n_2 el rendimiento dinámico.

El valor del rendimiento dinámico depende del tipo de reductor y del número de etapas de engranajes de reducción. Los reductores ortogonales de la serie K presentan un valor medio igual a: (η_d)
K..3 trenes = 0,9

$$P_H = \frac{M_H \cdot n_2}{9550 \cdot \eta_d}$$

3. Consultar las tablas de las prestaciones de los motorreductores buscando una potencia normalizada P_1 superior a la requerida P_H tal que:

$$P_1 \geq P_H$$

4. Una vez identificada la potencia normalizada adecuada, seleccionar el motorreductor capaz de desarrollar la velocidad angular más cercana a la n_2 deseada y con un factor de servicio f_b mayor o igual que el necesario para la aplicación

En las tablas de selección de los motorreductores, las combinaciones se realizan con motores de 2, 4, 6 polos alimentados con 50Hz. Para velocidades de accionamiento diferentes, consultar los datos nominales suministrados para los reductores.

DE TECHNISCHE INFORMATIONEN

Auswahl der Getriebe

1. Den Betriebsfactor der Anwendung bestimmen (f_B) (siehe Absatz "Betriebsfactor" S. 8-9).
2. Das benötigte Übersetzungsverhältnis i aus der erforderlichen Abtriebsdrehzahl n_2 und der Antriebsdrehzahl n_1 bestimmen.

$$i = \frac{n_1}{n_2}$$

3. Das Drehmoment M_G für die Auswahl des Getriebes über das von der Anwendung erforderliche Drehmoment M_{r2} und den Betriebsfaktor f_B ermitteln:

$$M_G = M_H \cdot (f_B)$$

4. Das Getriebe mit dem Übersetzungsverhältnis aus der Tabelle der Getriebedaten auswählen, das dem bestimmten Übersetzungsverhältnis am nächsten kommt und über ein ausreichendes Nenn Drehmoment M_2 verfügt, sodass:

$$M_2 \geq M_G$$

Überprüfungen

Nach der Auswahl des Getriebes oder des Getriebemotors ist es ratsam, die folgenden Überprüfungen durchzuführen:

A. Thermische Leistung

Die thermische Leistung des Getriebes muss gleich oder größer als die installierte mechanische Leistung sein oder als die von der Anwendung gemäß den im Abschnitt enthaltenen Angaben erforderliche Leistung (siehe Abschnitt "thermische Leistung" S.12-15).

B. Maximales Drehmoment

Grundsätzlich darf das maximale Drehmoment (momentane Spitzenbelastung), das an das Getriebe angewendet werden kann, nicht mehr als 200% des Nenn Drehmoments betragen.

C. Radiale Belastungen

Überprüfen Sie bitte dass die radialen Belastungen auf den Eingangs - und / oder Ausgangswellen die zugelassenen Katalogwerte nicht überschreiten.

Wenn diese größer sind, bitte die Getriebegröße anpassen oder die Auslegung für die externe Last anpassen.

In der Prüfphase berücksichtigen bitte berücksichtigen, dass die im Katalog angegebenen Werte sich auf Lasten beziehen, die auf die Mittelachse des Wellenüberstands wirken. Daher ist es notwendig mit den entsprechenden Formeln die zugelassene Last in der gewünschten Position zu bestimmen, falls diese in einer davon abweichenden Position angebracht wird (siehe Absatz "Radiale Belastungen S. 20-22).

EN TECHNICAL INFORMATION

Gear reducer selection

1. Determine the application's service factor (f_B) (consult to the "Service factor" paragraph on page 8-9).
2. Calculate the reduction ratio i from the requested output speed n_2 and from the input speed n_1 .

$$i = \frac{n_1}{n_2}$$

3. Calculate the torque M_G for selecting the gear reducer through the torque required by the application M_{r2} and the service factor f_B :

$$M_G = M_H \cdot (f_B)$$

4. Consult the gear reducer performance tables and identify the gear reducer that - with a reduction ratio closest to the calculated ratio - has a nominal torque M_2 such that

$$M_2 \geq M_G$$

Checks

Once the gear reducer or geared motor has been selected, the following checks should be performed:

A. Thermal Power

The gear reducer's thermal power must be equal to or greater than the installed mechanical power, or the power required by the application according to the indications contained in the section (refer to the "Thermal power" paragraph on page 12-15).

B. Maximum Torque

Generally, the maximum torque (peak instantaneous load) that can be applied to the gear reducer must not exceed 200% of the nominal torque.

C. Radial Loas

Verify that the loads acting on the input and/or output shaft are within with the values indicated in the catalogue. If they exceed these values, increase the size of the gear reducer or modify the external load capacity.

During the checking phase, it is important to remember that the values indicated in the catalogue refer to loads acting on the mid-point of the shaft protrusion, therefore, if the load is applied to a different position, appropriate formulas must be used to calculate the admissible load in the desired position (refer to the "Radial loads" paragraph on page 20-22).

IT INFORMAZIONI TECNICHE

Selezione dei riduttori

1. Determinare il fattore di servizio dell'applicazione (f_B) (vedi paragrafo "Fattore di servizio" pag. 8-9)
2. Calcolare il rapporto di riduzione i dalla velocità in uscita n_2 richiesta e dalla quella in entrata n_1 .

$$i = \frac{n_1}{n_2}$$

3. Ricavare il momento torcente M_G per la selezione del riduttore attraverso la coppia richiesta dall'applicazione M_{r2} ed il fattore di servizio f_B :

$$M_G = M_H \cdot (f_B)$$

4. Consultare le tabelle delle prestazioni dei riduttori cercando il riduttore che, col rapporto di riduzione più prossimo a quello calcolato, dispone di una coppia nominale M_2 tale che:

$$M_2 \geq M_G$$

Verifiche

Esguita la selezione del riduttore o del motoriduttore è opportuno effettuare le seguenti verifiche:

A. Potenza Termica

La potenza termica del riduttore deve essere uguale o maggiore della potenza meccanica installata o della potenza richiesta dall'applicazione secondo le indicazioni contenute nella sezione (vedi paragrafo "Potenza termica" pag 12-15).

B. Coppia Massima

Generalmente la coppia massima (picco di carico istantaneo) che può essere applicata al riduttore non deve superare il 200% della coppia nominale.

C. Carichi radiali

Verificare che i carichi radiali agenti sugli alberi di entrata e/o di uscita rispettino i valori ammessi a catalogo. Se superiori, aumentare la grandezza del riduttore o modificare la supportazione del carico esterno.

Nella fase di verifica occorre tenere conto che i valori indicati a catalogo si riferiscono a carichi agenti sulla mezziera della sporgenza dell'albero per cui, nel caso il carico sia applicato in posizione diversa è necessario determinare con le apposite formule il carico ammissibile nella posizione desiderata (vedi paragrafo "Carichi Radiali" pag 20-22).

FR

INFORMACION TECNICA

Sélection des réducteurs

1. Déterminer le facteur de service de l'application (f_B) (voir paragraphe "Facteur de service" page 8-9).
2. Calculer le rapport de réduction (i) à partir de la vitesse n_2 requise en sortie et de la vitesse en entrée n_1

$$i = \frac{n_1}{n_2}$$

3. Déterminer le moment de torsion M_G pour la sélection du réducteur à l'aide du couple M_{r2} requis par l'application et du facteur de service f.s.:

$$M_G = M_H \cdot (f_B)$$

4. Consulter les tableaux des performances des réducteurs en recherchant le réducteur disposant du rapport de réduction le plus proche du rapport calculé et présentant un couple nominal M_2 tel que:

$$M_2 \geq M_G$$

Vérifications

Une fois sélectionné le réducteur ou le motorréducteur, il convient d'effectuer les vérifications suivantes:

A. Puissance Thermique

La puissance thermique doit être égale ou supérieure à la puissance mécanique installée, ou à la puissance requise par l'application, conformément aux indications contenues dans la section (voir paragraphe "Puissance thermique" page 12-15).

B. Couple Maximal

Généralement, le couple maximal (pic de charge instantanée) pouvant être appliqué au réducteur, ne doit pas dépasser 200% du couple nominal.

C. Charges Radiales

Vérifier que les charges radiales agissant sur les arbres d'entrée et/ou de sortie respectent les valeurs admises dans le catalogue. Si elles sont supérieures, augmenter la taille du réducteur ou modifier le palier de la charge extérieure.

Durant la phase de vérification, il est nécessaire de tenir compte du fait que les valeurs indiquées dans le catalogue se réfèrent à des charges agissant sur la moitié de la partie saillante de l'arbre; par conséquent, en cas d'application de la charge dans une position différente, il est nécessaire de déterminer la charge admissible dans la position désirée à l'aide des formules spéciales (voir paragraphe "Charges radiales" page 20-22).

ES

INFORMACIÓN TÉCNICO

Selección de los reductores

1. Determinar el factor de servicio de la aplicación (f_B) (ver el párrafo "Factor de servicio" pág. 8-9).
2. Calcular la relación de reducción i entre la velocidad de salida n_2 requerida y la de entrada n_1

$$i = \frac{n_1}{n_2}$$

3. Obtener el momento de torsión M_G para seleccionar el reductor a través del par necesario para la aplicación M_{r2} y el factor de servicio f.s.:

$$M_G = M_H \cdot (f_B)$$

4. Consultar las tables de las prestaciones de los reductores buscando el reductor que, con la relación de reducción más próxima a la calculada, disponga de un par nominal M_2 tal que:

$$M_2 \geq M_G$$

Verificaciones

Una vez realiza la selección del reductor o del motorreductor es conveniente efectuar las siguientes verificaciones:

A Potencia Térmica

La potencia térmica del reductor debe ser mayor o igual que la potencia mecánica instalada o que la potencia requerida por la aplicación según las indicaciones contenidas en la sección (ver el párrafo "Potencia térmica" pág 12-15).

B Par Máximo

Generalmente el par máximo (pico de carga instantáneo) que se puede aplicar al reductor no debe superar el 200% del par nominal.

C Cargas Radiales

Verificar que las cargas radiales que actúan sobre los árboles de entrada y/o de salida respeten los valores admitidos según el catálogo. Si son mayores, aumentar el tamaño del reductor o modificar la capacidad de soportar la carga externa. En la fase de verificación, es necesario tener en cuenta que los valores indicados en el catálogo se refieren a carga estática aplicada en una posición diferente, es necesario determinar la carga admisible en la posición deseada con las fórmulas correspondientes (ver el párrafo "Cargas Radiales" pág. 20-22).

DE **BETRIEBSFAKTOR**

Der Betriebsfaktor (fb) hängt von den Betriebsbedingungen ab, unter denen das Getriebe betrieben wird. Die Parameter, die für eine korrekte Auswahl des Betriebsfaktors zu berücksichtigen sind, sind folgende:

- Belastungsart der angetriebenen Maschine: **U - M - H**
- Tägliche Betriebsdauer: **Std./Tag**
- Anlaufhäufigkeit: **Anl./Std.**

LAST : **U** - Gleichförmig $mfa \leq 0.3$
M - Mittlere Überlast $mfa \leq 3$
H - Hohe Überlast $mfa \leq 10$

mfa = Je/Jm

- mfa Massenträgheitswert
- Je (kgm²) äußeres Trägheitsmoment reduziert auf die Motorwelle
- Jm (kgm²) Motor-Trägheitsmoment

Bei mfa > 10 bitte mit unserem Kundendienst Kontakt aufnehmen.

U- Schneckenförderer für Leichtmaterial, Gebläse, Montagebänder, Bandförderer für Leichtmaterial, kleine Rührwerke, Kleinlastenaufzüge, Kreiselpumpen, Hebebühnen, Reinigungs - maschinen, Abfüllmaschinen, Prüfmaschinen, Bandförderer.

M- Wickelmaschinen, Vorrichtungen zur Zuführung bei Holzbearbeitungsmaschinen, Lastaufzüge, Auswuchtmaschinen, Gewindefräsmaschinen, mittlere Rührwerke und Mischer, Bandförderer für schwere Materialien, Winden, Schiebetore, Dünger Abkratzer, Verpackungsmaschinen, Betonmischmaschinen, Kranfahr- und Kranhubwerke, Fräsmaschinen, Biegemaschinen, Zahnrad-pumpen, Hubstapler, Drehtische.

H- Rührwerke für schwere Materialien, Scheren, Pressen, Schleudern, Winden und Aufzüge für schwere Materialien, Schleifmaschinen, Steinbrecher, Kettenbecherwerke, Bohrmaschinen, Hammermühlen, Exzenterpressen, Biegemaschinen, Drehtische, Scheuertrommeln, Vibrationsrüttler, Schneidemaschinen, Stanzen, Walzwerke, Zementmühlen.

EN **SERVICE FACTOR**

The service factor (fb) depends on the operating conditions the reduction unit is subjected to.

The parameters that need to be taken into consideration to select the most adequate service factor correctly comprise:

- Type of load of the operated machine: **U - M - H**
- Length of daily operating time: **hours/day**
- Start-up frequency: **starts/hour**

TYPE OF LOAD : **U** - Uniform $mfa \leq 0.3$
M - Moderate shocks $mfa \leq 3$
H - Heavy shocks $mfa \leq 10$

mfa = Je/Jm

- mfa factor of inertia
- Je (kgm²) moment of reduced external inertia at the drive-shaft
- Jm (kgm²) moment of inertia of motor

If mfa > 10 call our Technical Service.

U- Screw feeders for light materials, fans, assembly lines, conveyor belts for light materials, small mixers, lifts, cleaning machines, fillers, control machines.

M- Winding devices, woodworking machine feeders, goods lifts, balancers, threading machines, medium mixers, conveyor belts for heavy materials, winches, sliding doors, fertilizer scrapers, packing machines, concrete mixers, crane mechanisms, milling cutters, folding machines, gear pumps.

H- Mixers for heavy materials, shears, presses, centrifuges, rotating supports, winches and lifts for heavy materials, grinding lathes, stone mills, bucket elevators, drilling machines, hammer mills, cam presses, folding machines, turntables, tumbling barrels, vibrators, shredders.

IT **FATTORE DI SERVIZIO**

Il fattore di servizio (fb) dipende dalle condizioni di funzionamento alle quali il riduttore è sottoposto. I parametri che occorre considerare per una corretta selezione del fattore di servizio più adeguato sono:

- Tipo del carico della macchina azionata: **U-M-H**
- Durata di funzionamento giornaliero: ore/giorno
- Frequenza di avviamento: avv/ora

TIPO DEL CARICO : **U** - Uniforme $mfa \leq 0.3$
M - Medio $mfa \leq 3$
H - Forte $mfa \leq 10$

mfa = Je/Jm

- mfa fattore d'inertzia
- Je (kgm²) momento d'inertzia esterno ridotto all'albero motore
- Jm (kgm²) momento d'inertzia motore

Se mfa > 10 interpellare il ns. Servizio Tecnico.

U- Coclee per materiali leggeri, ventole, linee di montaggio, nastri trasportatori per materiali leggeri, piccoli agitatori, elevatori, macchine pulitrici, macchine riempitrici, macchine per il controllo, nastri trasportatori.

M- Dispositivi di avvolgimento, apparecchi per l'alimentazione delle macchine per il legno, montacarichi, equilibratrici, filettatrici, agitatori medi e mescolatori, nastri trasportatori per materiali pesanti, verricelli, porte scorrevoli, raschiatore di concime, macchine per l'imballaggio, betoniere, meccanismi per il movimento delle gru, frese, piegatrici, pompe a ingranaggi.

H- Agitatori per materiali pesanti, cesoie, prese, centrifughe, supporti rotanti, verricelli ed ascensori per materiali pesanti, torni per la rettifica, frantoi da pietre, elevatori a tazze, perforatrici, mulini a martello, presse as eccentrico, piegatrici, tavole rotanti, barilatrici, vibratori, trinciatrici.

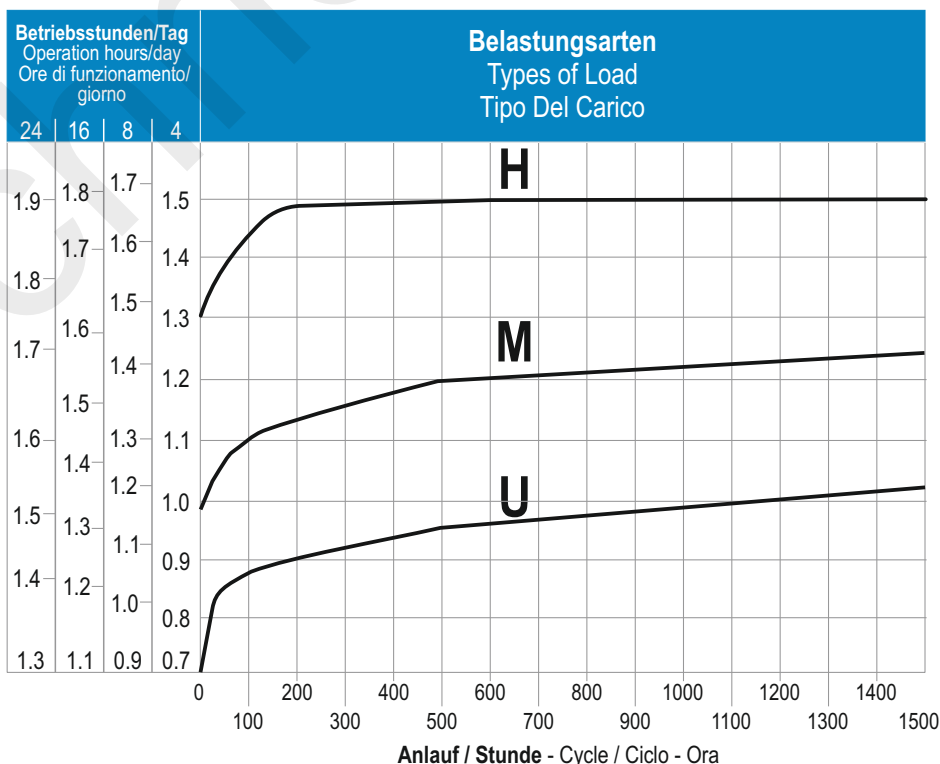

FR

FACTEUR DE SERVICE

Le facteur de service (fb) est subordonné aux conditions de fonctionnement auxquelles le réducteur est soumis. Les paramètres qu'il faut considérer pour un choix correct du facteur de service adéquat sont les suivants:

- Type de charge de la machine actionnée: **U-M-H**
- Durée de fonctionnement journalière: **heures / jour**
- Fréquence de démarrage: **dém / heure**

TYPE DE CHARGE : **U** - Uniforme mfa ≤ 0.3
M - Surcharge moyenne mfa ≤ 3
H - Surcharge forte mfa ≤ 10

mfa = Je/Jm

- mfa facteur d'inertie
 - Je (kgm²) moment d'inertie extérieur ramené à l'arbre-moteur
 - Jm (kgm²) moment d'inertie moteur
- En cas de mfa > 10, contacter notre S.ce Technique.

U- Vis d'Archimède pour matériaux légers, ventilateurs, lignes de montage, convoyeurs pour matériaux légers, petits agitateurs, élévateurs, machines à nettoyer, machines à remplir, machines pour le contrôle, convoyeurs.

M- Dispositifs d'enroulement, appareils pour l'alimentation des machines pour le bois, montecharges, équilibreuse, taraudeuses, agitateurs moyens et mélangeurs, convoyeurs pour matériaux lourds, treuils, portes coulissantes, racleurs d'engrais, machines à emballer, plieuses, pompes à engrènements.

H- Agitateurs pour matériaux lourds, cisailles, presses, centrifugeuses, supports rotatifs, treuils et ascenseurs pour matériaux lourds, tours pour la rectification, concasseurs de pierres, élévateurs à godets, perceuses, moulins à marteaux, presses à excentrique, plieuses, tables tournantes, polisseuses, vibrateurs, machines à hacher.

ES

FACTOR DE SERVICIO

El factor de servicio (fb) depende de las condiciones de funcionamiento a las cuales está sometido el reductor. Los parámetros que deben ser considerados para una correcta selección del factor de servicio más adecuado son:

- Tipo de carga de la máquina accionada: **U-M-H**
- Duración de funcionamiento diario: **horas/día**
- Frecuencia de arranques: **arr/hora**

TIPO DE CARGA : **U** - Uniforme mfa ≤ 0.3
M - Sobrecarga media mfa ≤ 3
H - Sobrecarga fuerte mfa ≤ 10

mfa = Je/Jm

- mfa factor de inercia
 - Je (kgm²) inercia externa reducida al eje motor
 - Jm (kgm²) inercia motor
- En caso de mfa > 10, ponerse en contacto con nuestro Servicio Técnico.

U- Tornillos de Arquímedes para materiales ligeros, ventiladores, líneas de montaje, cintas transportadoras para materiales ligeros, pequeños agitateurs, elevadores, máquinas limpiadoras, máquinas llenadoras, máquinas comprobadoras, cintas transportadoras.

M- Dispositivos de enrollado, alimentadores de las máquinas para la madera, montacargas, equilibradores, roscadoras, agitadores medios y mezcladores, cintas transportadoras para materiales pesados, cabrestantes, puertas corredizas, raspadores de abono, máquinas empaquetadoras, puertas corredizas, raspadores de abono, máquinas empaquetadoras, hormigoneras, mecanismos para el movimiento de las grúas, fresadoras, plegadoras, bombas de engranajes.

H- Agitadores para materiales pesados, cizallas, prensas, centrifugadoras, soportes rotativos, cabrestantes y elevadores para materiales pesados, tornos para la rectificación, molinos de piedras, elevadores de cangilones, perforadoras, molidores a percusión, prensas de excéntrica, plegadoras, mesas giratorias, pulidoras, vibradores, cortadoras.

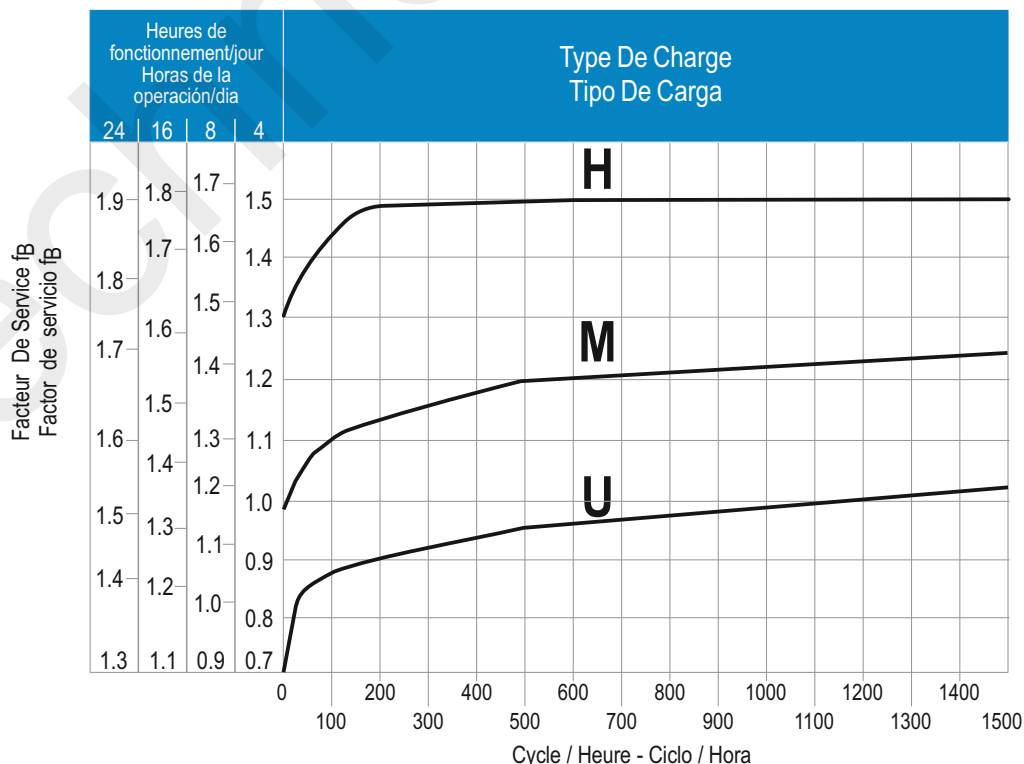

DE KRITISCHE ANWENDUNGEN

EN CRITICAL APPLICATIONS

IT APPLICAZIONI CRITICHE

Die im Katalog aufgeführten Leistungsdaten gelten für die Einbaulage M1 oder gleichwertig, wenn das Ritzel nicht völlig mit Öl geschmiert wird. Für andere Einbaulagen und/oder besondere Antriebsdrehzahlen sind die Tabellen zu beachten, die verschiedene kritische Zustände für jede Getriebegröße darstellen. Darüber hinaus sind nachstehende Anwendungen zu beachten und eventuell sollte mit unserem Kundendienst Kontakt aufgenommen werden:

- Nicht verwendbar als Übersetzungsgetriebe
- Anwendungen, die bei Bruch des Getriebes für den Menschen gefährlich sein könnten.
- Anwendungen mit sehr hohen Trägheitsmomenten.
- Einsatz als Hebewinde.
- Anwendungen mit hohen dynamischen Beanspruchungen auf Getriebegehäuse.
- Einsatz bei Umgebungstemperaturen unter -5°C oder über 40°C.
- Einsatz in Verbindung mit aggressiven chemischen Substanzen.
- Einsatz unter Salzwassereinwirkung.
- Nicht im Katalog vorgesehene Einbaulagen.
- Einsatz unter radioaktiver Strahlung.
- Einsatz unter einem Druck, der nicht dem normalem Luftdruck entspricht.

Anwendungen, bei denen das Eintauchen der Getriebe in Wasser vorgesehen ist (auch teilweise), sollen vermieden werden.

Das max. zulässige Drehmoment (*) der Getriebe, darf nicht den zweifachen Wert des in der Leistungstabelle angegebenen nominalen Wert des Drehmomentes (fb =1) übersteigen. (*) Hierbei sind Überlasten gemeint, welche durch Anlaufen unter Vollast, Bremsungen, Stöße und weitere dynamische Ursachen, hervorgerufen werden.

The performance given in the catalogue correspond to mounting position M1 or similar, ie. when the first stage is not entirely immersed in oil. For other mounting positions and/or particular input speeds, refer to the tables that highlight different critical situations for each size of reduction unit. It is also necessary to take due consideration of and carefully assess the following applications by calling our Technical Service:

- To avoid the use as multiplier
- Use in services that could be hazardous for people if the reduction unit fails.
- Applications with especially high inertia.
- Use as a lifting winch.
- Applications with high dynamic strain on the case of the reduction unit.
- In places with T° under -5°C or over 40°C.
- Use in chemically aggressive environments.
- Use in a salty environment.
- Mounting positions not envisaged in the catalogue.
- Use in radioactive environments.
- Use in environments pressures other than atmospheric pressure.

Avoid applications where even partial immersion of the reduction unit is required.

The maximum torque (*) that the gear reducer can support must not exceed two times the nominal torque (fb=1) stated in the performance tables. (*) intended for momentary overloads due to starting at full load, braking, shocks or other causes, particularly those that are dynamic.

Le prestazioni indicate a catalogo corrispondono alla posizione M1 o similari, quando cioè il primo stadio non è interamente immerso in olio. Per situazioni di pinnamento diverse e/o velocità di ingresso particolari attenersi alle tabelle che evidenziano situazioni critiche diverse per ciascuna taglia di riduttore. Occorre anche tenere nella giusta considerazione e valutare attentamente le seguenti applicazioni consultando il ns. Servizio Tecnico:

- Evitare l'utilizzo come moltiplicatore.
- Utilizzo in servizi che potrebbero risultare pericolosi per l'uomo in caso di rottura del riduttore.
- Applicazioni con inerzie particolarmente elevate.
- Utilizzo come argano di sollevamento.
- Applicazioni con elevate sollecitazioni dinamiche sulla cassa del riduttore.
- Utilizzo in ambiente con T° inferiore a -5°C o superiore a 40°C.
- Utilizzo in ambiente con presenza di aggressivi chimici.
- Utilizzo in ambiente salmastro.
- Posizioni di piazzamento non previste a catalogo.
- Utilizzo in ambiente radioattivo.
- Utilizzo in ambiente con pressione diversa da quella atmosferica.

Evitare applicazioni dove è prevista l'immersione, anche parziale, del riduttore.

La coppia massima (*) sopportabile dal riduttore non deve superare il doppio della coppia nominale (fb =1) riportata tabelle delle prestazioni.

(*) intesa come sovraccarico istantaneo dovuto a avviamenti a pieno carico, frenature, urti ed altre cause soprattutto dinamiche.

K	35390	40390	50390	60390	70390	90390	100390
2000 < n1 < 3000	-	-	-	P	P	P	P
M2	P	P	P	P	P	P	P
n1 > 3000	P	P	P	P	X	X	X
... L : M5 - M6	P	P	P	P	P	P	P

X Nicht empfohlene Anwendung
Application not recommended
Applicazione sconsigliata

P Anwendung überprüfen und/oder mit unserem Kundendienst Kontakt aufnehmen.
Check the application and/or call our technical service.
Verificare l'applicazione e/o contattare il ns. servizio tecnico.

FR APPLICATIONS CRITIQUES

Les performances indiquées sur le catalogue correspondent à la position M1 ou similaires, lorsque le premier train d'engrenage n'est pas entièrement immergé dans l'huile. Pour les combinaisons d'assemblage différentes et/ou les vitesses d'entrée particulières, se conformer aux tableaux qui mettent en évidence les différentes situations critiques pour chaque taille de réducteur.

Il faut aussi prendre en considération et évaluer attentivement les applications suivantes, en consultant notre S.ce Technique:

- Éviter l'utilisation comme multiplicateur.
- Emploi en services qui pourraient être dangereux pour l'homme en cas de rupture du réducteur.
- Applications avec inerties particulièrement élevées.
- Emploi comme treuil, en cas de soulèvement.
- Applications avec sollicitations dynamiques sur la carcasse du réducteur.
- Emploi en milieu avec température au - dessous de -5°C ou au-dessus de 40°C.
- Emploi en milieu en présence d'agents chimiques agressifs.
- Emploi en milieu saumâtre.
- Positions de montage non prévues sur le catalogue.
- Emploi en milieu radioactif.
- Emploi en milieu ayant une pression différente de celle atmosphérique.

Éviter les applications dans lesquelles l'immersion du réducteur, même si partielle, est prévue.

Le couple maximum (*) supporté par le réducteur ne doit pas être supérieur au double du couple nominal ($f_b = 1$) suivant notre table de prestation.

(*) Entendu comme surcouple instantané dû à démarrages en pleine charge, freinages, chocs et autres causes surtout dynamiques.

ES APLICACIONES CRITICAS

Las prestaciones indicadas en el catálogo corresponden a la posición M1 o similares, cuando el primer tren de engranajes no está completamente inmerso en el aceite. Para posiciones de montaje distintas y/o de velocidades particulares a la entrada, atenderse a las tablas que ponen en evidencia las distintas situaciones críticas por cada tamaño de reductor.

Además es necesario considerar y evaluar cuidadosamente las siguientes aplicaciones, poniéndose en contacto con nuestro Servicio técnico:

- Evitar la utilización como multiplicador.
- Utilización en servicios que, en caso de ruptura del reductor, podrían resultar peligrosos para el hombre.
- Aplicaciones con inercias particularmente elevadas.
- Utilización como cabrestante de levantamiento.
- Aplicaciones con esfuerzos dinámicos elevados sobre la carcasa del reductor.
- Utilización en ambiente con T° inferior a -5°C o superior a 40°C.
- Utilización en ambiente con presencia de agentes químicos agresivos.
- Utilización en ambiente salino.
- Posiciones en montaje no previstas en el catálogo.
- Utilización en ambiente radioactivo.
- Utilización en ambiente con presión distinta de la atmosférica.

Evitar aplicaciones donde está prevista la inmersión, aún parcial, del reductor.

El par máximo (*) soportable por el reductor no debe superar el doble del par nominal ($f_b = 1$) indicado en la tabla de prestaciones.

(*) Entendida como sobrecarga instantánea debida a puestas en marcha a plena carga, frenadas, impactos y otras causas sobretodo dinámicas.

K	35390	40390	50390	60390	70390	90390	100390
2000 < n1 < 3000	-	-	-	P	P	P	P
M2	P	P	P	P	P	P	P
n1 > 3000	P	P	P	P	X	X	X
... L : M5 - M6	P	P	P	P	P	P	P

X Application non conseillée
Aplicación desaconsejada

P Verifier l'application et/ou contacter notre s.ce technique.
Controlar la aplicación y/o ponerse en contacto con nuestro servicio técnico.

DE THERMISCHE LEISTUNG Pt [kW]

Die folgende Tabelle enthält die Werte der thermischen Nennleistung in kW unter den folgenden Referenzbedingungen:

- Montageposition M1
- Dauerbetrieb mit Eingangsgeschwindigkeit ≤1400 rpm
- Umgebungstemperatur von 25°C
- Höhe über dem Meeresspiegel
- Geschwindigkeit der Luft im Getriebeinneren ≥1m/s
- Abwesenheit von radialen und/oder axialen externen Belastungen

EN THERMAL POWER Pt [kW]

The table below list the nominal thermal power values expressed in kW, in the following reference conditions:

- mounting position M1
- continuous operation at input speed ≤1400 rpm
- ambient temperature 25°C
- sea level altitude
- air speed near the gear reducer ≥1m/s
- absence of external radial and/or axial loads

IT POTENZA TERMICA Pt [kW]

La seguente tabella riporta i valori di potenza termica nominale espressa in kW nelle seguenti condizioni di riferimento:

- posizione di montaggio M1
- funzionamento continuo con velocità di entrata ≤1400 rpm
- temperatura ambiente di 25°C
- altitudine pari al livello del mare
- velocità dell'intorno del riduttore ≥1m/s
- assenza di carichi radiali e/o assiali esterni

Thermische Leistungen bei 1400 rpm / Thermal power values at 1400 rpm / Potenza termiche a 1400rpm	
Getriebe / Gear reducer / Riduttore	Pt [kW]
K35390	10.5
K40390	11.0
K50390	12.5
K60390	19.0
K70390	22.5
K90390	38.0
K100390	55.0

Durch die Anwendung einer die Pt nicht übersteigenden Leistung an das Getriebe wird eine ausreichende Schmierung und eine gute Funktionsweise des Getriebes gewährleistet.

Applying a power level not exceeding Pt at the above mentioned reference conditions guarantees the correct lubrication and efficient operation of the gear reducer.

Applicando al riduttore, nelle suddette condizioni di riferimento una potenza non superiore a Pt, risultano garantiti una corretta lubrificazione ed il buon funzionamento del riduttore.

Prüfung der Anwendung

Mit Ausnahme von durchgängigen Betriebszeiten unter zwei (2) Stunden und anschließenden Pausen, bei denen das Getriebe auf die Umgebungstemperatur abkühlt, ist es ratsam bei jeder Anwendung die thermische Grenze des Getriebes mit der folgenden Formel zu überprüfen:

$$P1 < Pt * Fc * Fv * Fa$$

dabei ist :

P1 = Eingangsleistung des Getriebes 1400 rpm (Motor mit 4 Polen)

Pt = Thermische Leistung unter Referenzbedingungen (siehe Tabelle oben)

Fc = Korrekturfaktor für Umgebungstemperatur und Betrieb

Fv = Korrekturfaktor für Belüftung

Fa = Korrekturfaktor für Höhe über NN

Die Korrekturfaktoren beziehen sich auf Betriebsbedingungen, die von den Referenzbedingungen abweichen und werden in den folgenden ISO 14179 Tabellen aufgeführt:

Application check

Except for continuous operating times below two (2) hours and successive pauses capable of bringing the gear reducer back to ambient temperature, for each application it is advisable to verify the gear reducer's thermal limit according to the following formula:

$$P1 < Pt * Fc * Fv * Fa$$

where:

P1 = input power to the gear reducer at 1400 rpm (4-pole motors)

Pt = thermal power at reference conditions (see above table)

Fc = ambient and operating temperature correction factor

Fv = ventilation correction factor

Fa = altitude correction factor

The correction factors refer to different operating conditions compared to the reference conditions, and are provided by following ISO 14179 tables:

Verifica della applicazione

Fatta eccezione per tempi di funzionamento continuo inferiori a due (2) ore e successive pause in grado di riportare il riduttore a temperatura ambiente, per ogni applicazione è consigliabile eseguire la verifica del limite termico del riduttore, secondo la seguente formula:

$$P1 < Pt * Fc * Fv * Fa$$

dove:

P1 = potenza in ingresso al riduttore a 1400 rpm (motori a 4 poli)

Pt = potenza termica in condizioni di riferimento (vedi tabella sopra)

Fc = fattore correttivo di temperatura ambiente e servizio

Fv = fattore correttivo di aerazione

Fa = fattore correttivo dell'altitudine

I fattori correttivi sono relativi a condizioni operative differenti da quelle di riferimento, e sono forniti dalle seguenti tabelle ISO 14179:

FR PUISSANCE THERMIQUE Pt [kW]

ES POTENCIA TÉRMICA Pt [kW]

Le tableau suivant présente les valeurs de puissance thermique nominale exprimées en kW dans les conditions de référence suivantes:

- position de montage M1
- fonctionnement continu avec vitesse d'entrée ≤1400 rpm
- température ambiante de 25°C
- altitude égale au niveau de la mer
- vitesse de l'air à proximité du réducteur ≥1m/s
- absence de charges radiales et/ou axiales externes

La siguiente tabla contiene los valores de potencia térmica nominal expresada en kW en las siguientes condiciones de referencia:

- posición de montaje M1
- funcionamiento continuo con velocidad de entrada ≤1400 rpm
- temperatura ambiente de 25°C
- altura sobre el nivel del mar
- velocidad del aire en torno al reductor ≥1m/s
- ausencia de cargas radiales y/o axiales externas

Puissances thermiques à 1400 rpm / Potencias térmicas a 1400 rpm	
Réducteur / Reductor	Pt [kW]
K35390	10.5
K40390	11.0
K50390	12.5
K60390	19.0
K70390	22.5
K90390	38.0
K100390	55.0

L'application au réducteur d'une puissance inférieure à la Pt, dans les conditions de référence indiquées ci-dessus, garantit une lubrification correcte et le bon fonctionnement du réducteur.

En las condiciones de referencia mencionadas, aplicando al reductor una potencia no mayor que la Pt, se garantiza una correcta lubricación y el buen funcionamiento del reductor.

Vérification de l'application

À l'exception de périodes de fonctionnement continu inférieures à deux (2) heures et de pauses successives permettant au réducteur de redescendre à une température ambiante pour toute application, il est conseillé d'effectuer une vérification de la limite thermique du réducteur, selon la formule suivante

$$P1 < Pt * Fc * Fv * Fa$$

où:

P1 = puissance d'entrée au réducteur à 1400tr/min (moteurs à 4 p-pôles)

Pt = puissance thermique dans les conditions de référence (voir tableau ci-dessus)

Fc = facteur de correction de température ambiante et de service

Fv = facteur de correction d'aération

Fa = facteur de correction de l'altitude

Les facteurs de correction correspondent à des conditions de fonctionnement différentes de celles de référence, et sont fournis par les tableaux ISO 14179 suivants:

Controlar la aplicación

Salvo cuando los tiempos de funcionamiento continuo son menores que dos (2) horas y se producen pausas capaces de llevar el reductor a la temperatura ambiente, para cada aplicación es aconsejable realizar la verificación del límite térmico del reductor, según la siguiente fórmula:

$$P1 < Pt * Fc * Fv * Fa$$

donde:

P1 = potencia a la entrada del reductor a 1400rpm (motores de 4 polos)

Pt = potencia térmica en condiciones de referencia (ver la tabla de arriba)

Fc = factor de corrección de la temperatura ambiente y servicio

Fv = factor de corrección de aireación

Fa = factor de corrección de la altitud

Los factores de corrección son relativos a condiciones operativas diferentes a las de referencia y se encuentran en las siguientes tablas ISO 14179:

DE THERMISCHE LEISTUNG Pt [kW]

EN THERMAL POWER Pt [kW]

IT POTENZA TERMICA Pt [kW]

Fc		Betriebszeit in % pro Stunde / Duty per hour of operation % / Servizio a carico ora di funzionamento %				
		100	80	70	40	20
Umgebungs- temperatur	10°C	1.15	1.21	1.32	1.55	2.07
	18°C	1.07	1.12	1.23	1.44	1.93
	25°C	1.00	1.05	1.15	1.35	1.80
Ambient temperature	30°C	0.93	0.98	1.07	1.26	1.67
Temperatura ambiente	40°C	0.83	0.87	0.95	1.12	1.49
	43°C	0.75	0.79	0.86	1.01	1.35
	50°C	0.67	0.70	0.77	0.90	1.21

Geschwindigkeit der Umgebungsluft / Ventilation correction factor / Velocità dell'aria ambientale	Fv
Stehende Luft (<0,5 m/s) / Stagnant air (<0,5 m/s) / Aria stagnante (<0,5 m/s)	0.75
Installation in geschlossenen Räumen mit geringer Luftzirkulation / Indoor installation with slight ventilation / Installazione al chiuso con lieve aerazione	1
Installation in geschlossenen Räumen mit guter Luftzirkulation (>1,4 m/s) / Indoor installation with good ventilation (>1,4 m/s) / Installazione al chiuso con aerazione (>1,4 m/s)	1.4
Installation im Freien (>3,7 m/s) / Outdoor installation (>3,7 m/s) / Installazione all'aperto (>3,7 m/s)	1.9

Höhe über NN / Altitude correction factor / Altitudine	Fa
0*	1
750	0.95
1500	0.90
2250	0.85
3000	0.81

* Meeresniveau

* Sea level

*Livello del mare

Im Fall eines Betriebs mit Eingangsgeschwindigkeiten über 2000 rpm oder bei Umgebungstemperaturen über 40°C wird empfohlen, den Kundendienst zu kontaktieren

In caso of operation at input speeds exceeding 2000 rpm, or ambient temperatures greater than 40°C it is advisable to contact out technical department.

In caso di funzionamento con velocità di ingresso maggiori di 2000 rpm, o temperature ambiente maggiori di 40°C è consigliabile contattare il ns servizio di assistenza.

FR PUISSANCE THERMIQUE Pt [kW]

ES POTENCIA TÉRMICA Pt [kW]

Fc		Facteur de marche par heure de fonctionnement % / Servicio con carga por hora de funcionamiento %				
		100	80	70	40	20
Température ambiante	10°C	1.15	1.21	1.32	1.55	2.07
	18°C	1.07	1.12	1.23	1.44	1.93
	25°C	1.00	1.05	1.15	1.35	1.80
Temperatura ambiente	30°C	0.93	0.98	1.07	1.26	1.67
	40°C	0.83	0.87	0.95	1.12	1.49
	43°C	0.75	0.79	0.86	1.01	1.35
	50°C	0.67	0.70	0.77	0.90	1.21

Vitesse de l'air ambiant / Velocidad del arie ambiental	Fv
Air stagnant (<0,5 m/s) / Aire estancado (<0,5 m/s)	0.75
Installation en intérieur avec une légère aération / Instalación cubierta con poca aireación	1
Installation en intérieur avec une aération correcte (>1,4 m/s) / Instalación cubierta con buena aireación (>1,4 m/s)	1.4
Installation en extérieur (>3,7 m/s) / Instalación al aire libre (>3,7 m/s)	1.9

Altitude / Altitud	Fa
0*	1
750	0.95
1500	0.90
2250	0.85
3000	0.81

* Niveau de la mer

* Nivel del mar

En cas de fonctionnement avec des vitesses d'entrée supérieures à 2000 tr/min ou en présence de températures ambiantes supérieures à 40°C, il est conseillé de contacter notre service d'assistance.

En el caso de funcionamiento con velocidades de entrada mayores que 2000 rpm o temperaturas ambiente mayores que 40°C es aconsejable llamar a nuestro servicio de asistencia técnica.

DE MONTAGE DES MOTORS AN DEN PAM-IEC FLANSCH B5

Bei Getrieben, welche ohne Motor geliefert werden, sind folgende Vorsichtsmaßnahmen zu beachten, um eine korrekte Montage des Elektromotors zu gewährleisten. Übereinstimmung der Toleranzen von Welle und Motorflansch überprüfen.

Diese sollten mindestens DIN 42955 N entsprechen. Welle, Passung und Flanschfläche sind sorgfältig von Schmutz, Späne oder Lackresten zu säubern.

Halbkupplung auf Motor (siehe Bild) einsetzen, andernfalls sind die korrekte Ausrichtung und die Toleranz der Passfeder zu überprüfen. In jedem Fall sind solche Montageverfahren anzuwenden, die Schäden an den Motorlagern ausschließen.

Motor anbauen, wobei es zuerst darauf geachtet werden muss, dass die Halbkupplung auf dem Motor und der elastische Zwischenring auf der Getriebehalkkupplung frei eingreifen können.

Keine Anpassung der Motorpaßfeder ist in diesem Fall erforderlich.

EN MOTOR MOUNTING WITH PAM-IEC FLANGE B5

When the unit is supplied without motor, it is necessary to follow these recommendation to ensure the correct assembly of the electric motor. Assembly of flange mounting motors to the gear unit with the PAM flange uses a coupling. Check that the tolerances for the motor shaft and flange correspond to the standard. Carefully clean the shaft, spigot and surfaces of the flange removing traces of paint and dirt, and confirm the key is fitted correctly.

Fit the half coupling to the motor shaft (see picture) taking care to ensure the motor shaft and bearings are not damaged by avoiding excessive force and where necessary using assembly equipment.

Place the couplings elastic element onto the motor half coupling and position the motor up to the gear unit ensuring the coupling element is aligned with the driven half coupling. Complete the assembly using the fixing bolts. Key-ways with tightened tolerances.

IT MONTAGGIO MOTORE SU FLANGE PAM-IEC B5

Quando il gruppo viene fornito senza motore occorre osservare le seguenti raccomandazioni per garantire un corretto montaggio del motore elettrico.

Controllare che le tolleranze dell'albero e della flangia motore siano corrispondenti almeno a una classe di qualità "normale". Pulire accuratamente l'albero, il centraggio ed il piano della flangia da sporco o tracce di vernice.

Procedere al montaggio del semigiunto (vedi figura) sull'albero del motore elettrico che deve avvenire senza eccessiva forzatura in caso diverso controllare la corretta posizione e la tolleranza della linguetta motore; utilizzare comunque opportuni sistemi che garantiscano un corretto montaggio senza rischiare il danneggiamento dei cuscinetti motore. Procedere quindi al montaggio del motore completo di semigiunto facendo i denti di trascinamento del semigiunto lato motore con quelli dell'elemento elastico presente sul semigiunto fisso lato riduttore. Non è previsto nessun adattamento della linguetta motore.

FR INSTALLATION MOTEUR SUR BRIDE PAM-IEC B5

Quand le groupe est fourni sans moteur, observez les recommandations suivantes pour garantir un montage correct du moteur électrique.

Contrôler que les tolérances de l'arbre et de la bride du moteur correspondent au moins à une classe de qualité «normale».

Nettoyer soigneusement l'arbre, le centrage et le plan de la bride des traces de saleté et de peinture.

Procéder au montage de demi-accouplement sur l'arbre moteur électrique sans forcer (voir image), dans le cas contraire, vérifier la position correcte et la tolérance de la clavette du moteur.

Utiliser, toutefois, des systèmes appropriés qui garantissent un montage correct sans risquer de détériorer les roulements du moteur.

Procéder de la même façon pour le montage du moteur avec le demiaccouplement coté moteur avec de l'élément élastique du demiaccouplement coté réducteur. Rainures clavette moteur avec tolérances réduites.

ES GUÍA PARA LA SELECCIÓN DEL PRODUCTO

Sie al equipo se suministra sin motor es preciso observar las siguientes recomendaciones para garantizar un correcto montaje del motor eléctrico.

Verificar que la tolerancia del eje y de la brida motor se correspondan al menos a una clase de calidad "normal".

Limpiar cuidadosamente el eje, el centrage y el plano de asiento de restos de barniz o suciedad.

Proceder al montaje del semiacoplamiento en el eje del motor eléctrico sin excesiva fuerza, si no entra con suavidad verificar la correcta tolerancia de la chaveta del motor (ver imagen), utilizar en cualquier caso métodos de montaje que no dañen los rodamientos del motor.

Proceder a continuación al montaje del motor con el semiacoplamiento en el reductor, evitando la interferencia de los dientes del acoplamiento.

No se prevé ninguna adaptación de la chaveta del motor.

IEC BUCHSE / IEC SLEEVE / MANICOTTO IEC / MANCHON IEC / MANGUÍTO IEC

K ... - DA/B14 - IEC

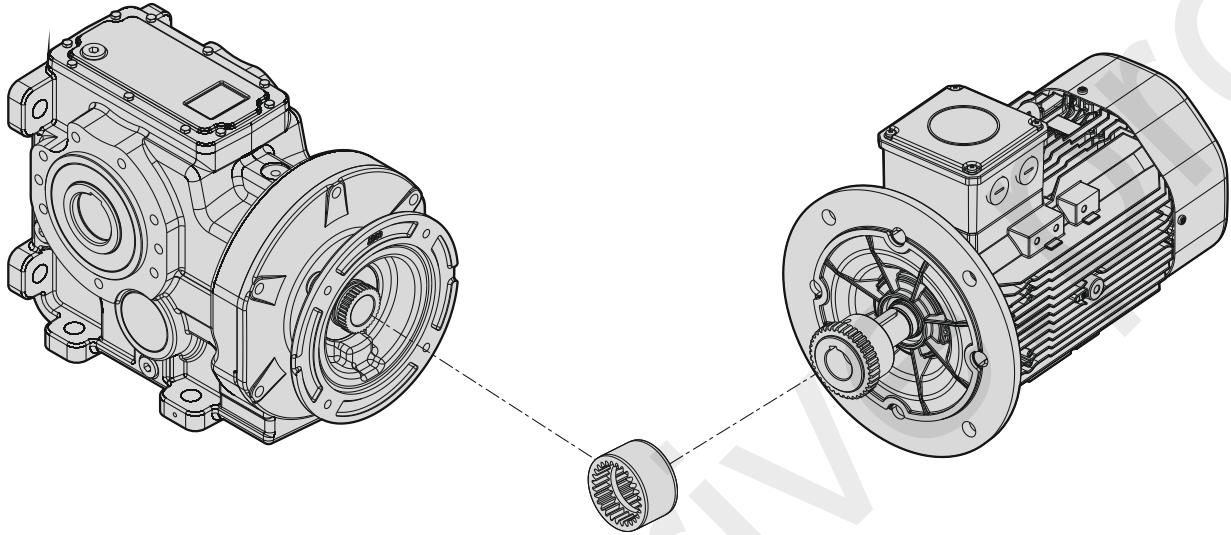

PAM BUCHSE / PAM SLEEVE / MANICOTTO PAM / MANCHON PAM / MANGUÍTO PAM

K ... - DA/B14 PAM

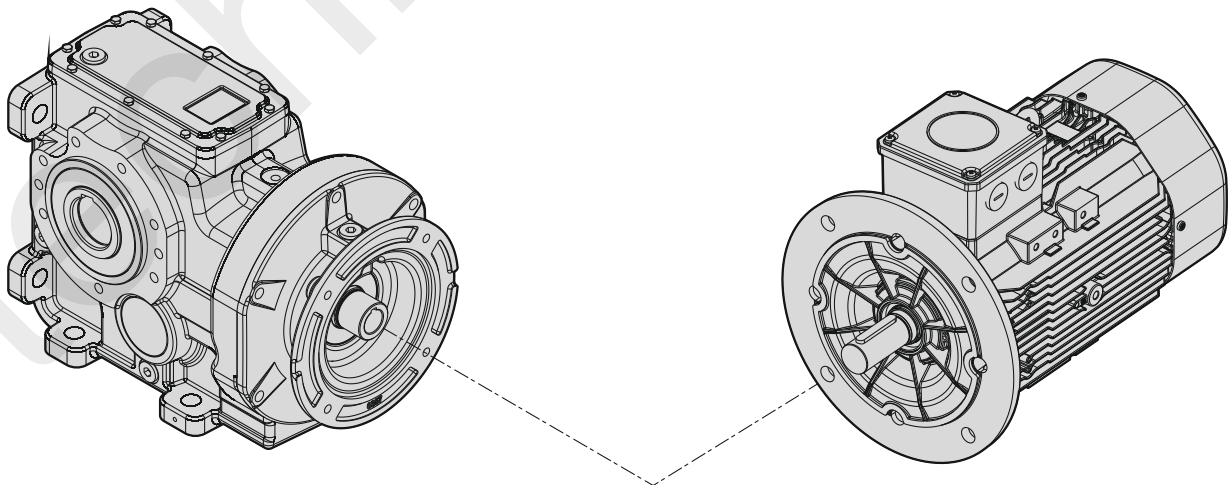

DE MONTAGE

Für die Montage des Getriebes sind nachstehende Anweisungen zu beachten:

- Die Befestigung an der Maschine muss absolut stabil sein, um jegliche Vibrationen zu vermeiden.
- Vor der Montage des Getriebes an der Maschine ist die Abtriebswelle des Getriebes auf die richtige Drehrichtung zu prüfen.
- Nach besonders langer Einlagerung (4/6 Monate) ist zu überprüfen, ob die Wellendichtringe vom Schmiermittel des Getriebes vollständig benetzt wurden; Andernfalls ist ein Austausch anzuraten, da die Dichtlippe auf der Welle festkleben kann oder die zum einwandfreien Betrieb notwendige Elastizität nicht mehr vorhanden ist.
- Wenn möglich, sollte das Getriebe vor Sonneneinstrahlung u.a. Witterungseinflüssen geschützt werden.
- Die Motorkühlung muss durch eine gute Belüftung durch den Lüfter gewährleistet werden.
- Bei Umgebungstemperaturen < -5°C oder > +40°C setzen Sie sich bitte mit dem Kundendienst in Verbindung.
- Zur Montage der unterschiedlichen Anbauteile (Riemenscheiben, Zahnräder, Kupplungen, Wellen usw.) auf den Hohl- oder Vollwellen sind die vorgesehenen Gewindebohrungen oder Aufziehvorrichtungen zu verwenden. Diese gewährleisten eine einwandfreie Montage, ohne die Lager oder die Außenteile des Getriebes zu beschädigen. Die in Berührung kommenden Passungen und Oberflächen der Wellen sind zu fetten/ölen, um ein Festfressen durch Passungsrost zu vermeiden.
- Bei Lackierung ist darauf zu achten, dass alle Gummiteile und fallweise die in den Entlüftungsdeckeln vorhandenen Bohrungen nicht überlackiert werden.
- Bei Getrieben mit Ölstopfen ist die zum Transport verwendete Verschlusschraube durch die beigelegte Entlüftungsschraube zu ersetzen.
- Der Schmierölstand ist an der Füllstandsanzeige zu überprüfen, sofern vorhanden.
- Der Antrieb ist stufenweise in Betrieb zu nehmen, wobei zunächst mit Teillast angefahren werden sollte.
- Sind unter dem Antrieb Gerätteile oder Materialien angeordnet, die durch geringe Mengen austretenden Öls beschädigt werden könnten, so ist eine geeignete Schutzvorrichtung vorzusehen.

EN INSTALLATION

To install the reduction unit it is necessary to note the following Recommendations:

- The mounting on the machine must be stable to avoid any vibration
- Check the correct direction of rotation of the gear reducer output shaft before fitting the unit to the machine.
- In the case of particularly lengthy periods of storage (4/6 months), if the oil seal is not immersed in the lubricant inside the unit, it is recommended to change it since the rubber could stick to the shaft or may even have lost the elasticity it needs to function properly.
- Whenever possible, protect the reduction unit against solar radiation and bad weather.
- Ensure the motor cools correctly by assuring good passage of air from the fan side.
- In the case of ambient temperatures < -5°C or > +40°C call the Technical Service.
- The various parts (pulleys, gear wheels, couplings, shafts, etc.) must be mounted on the solid or hollow shafts using special threaded holes or other systems that anyhow ensure correct operation without risking damage to the bearings or external parts of the units. Lubricate the surfaces in contact to avoid seizure or oxidation.
- Painting must definitely not go over rubber parts and the holes on the breather plugs, if any.
- For units equipped with oil plugs, replace the closed plug used for shipping with the special breather plug.
- Check the correct level of the lubricant through the indicator, if there is one.
- Starting must take place gradually, without immediately applying the maximum load.
- When there are parts, objects or materials under the motor drive that can be damaged by even limited spillage of oil, special protection should be fitted.

IT INSTALLAZIONE

Per l'installazione del riduttore è consigliabile attenersi alle seguenti indicazioni:

- Il fissaggio sulla macchina deve essere stabile per evitare qualsiasi vibrazione.
- Verificare il corretto senso di rotazione dell'albero di uscita del riduttore prima del montaggio del gruppo sulla macchina.
- In caso di periodi particolarmente lunghi di stoccaggio (4/6 mesi) se l'anello di tenuta non è immerso nel lubrificante contenuto all'interno del gruppo si consiglia la sua sostituzione in quanto la gomma potrebbe essersi incollata all'albero o addirittura aver perso quelle caratteristiche di elasticità necessarie al corretto funzionamento.
- Quando possibile proteggere il riduttore dall'irraggiamento solare e dalle intemperie.
- Garantire un corretto raffreddamento del motore assicurando un buon passaggio d'aria dal lato ventola.
- Nel caso di temperature ambiente < -5°C or > +40°C contattare il servizio Assistenza Tecnica.
- Il montaggio dei vari organi (pulegge, ruote, dentate, giunti, alberi, ecc.) sugli alberi pieni o cavi deve essere eseguito utilizzando appositi fori filettati o altri sistemi che comunque garantiscano una corretta operazione senza rischiare il danneggiamento dei cuscinetti o delle parti esterne dei gruppi. Lubrificare le superfici a contatto per evitare grippaggi o ossidazioni.
- La verniciatura non deve assolutamente interessare le parti in gomma e i fori esistenti sui tappi di sfato, quando presenti.
- Per i gruppi provvisti di tappi per olio sostituire il tappo chiuso utilizzato per la spedizione con l'apposito tappo di sfato.
- Controllare il corretto livello del lubrificante tramite, quando prevista l'apposita spia.
- La messa in funzione deve avvenire in maniera graduale, evitando l'applicazione immediata del carico massimo.
- Quando sotto alla motorizzazione sono presenti organi, cose o materiali danneggiabili dall'eventuale fuoriuscita, anche limitata, di olio è opportuno prevedere un'apposita protezione.

FR

INSTALLATION

Pour l'installation du réducteur, il faut se conformer aux indications suivantes:

- La fixation sur la machine doit être stable pour éviter toute vibration.
- Avant le montage du groupe sur la machine, vérifier que le sens de rotation de l'arbre de sortie du réducteur soit correct.
- En cas de périodes de stockage particulièrement longues (4/6 mois), si la bague d'étanchéité n'est pas immergée dans le lubrifiant contenu à l'intérieur du groupe, on conseille son remplacement, car le caoutchouc pourrait être collé à l'arbre ou avoir perdu les caractéristiques d'élasticité nécessaires à un fonctionnement correct.
- Si possible, protéger le réducteur des rayons du soleil et des intempéries.
- Vérifier que le refroidissement du moteur soit suffisant, en assurant un bon passage d'air du côté ventilateur.
- En cas de températures ambiante <-5°C ou >+40°C, contacter le Service techniques.
- Le montage de différents organes (poules, roues dentées, accouplements, arbres, etc.) sur les arbres pleins ou creux doit être effectué en utilisant les trous filetés ou d'autres systèmes assurant de toute façon une opération correcte, sans risquer d'endommager les roulements ou les parties extérieures des groupes. Lubrifier les surfaces en contact, afin d'éviter le grippage ou l'oxydation.
- La peinture ne doit absolument pas toucher les parties en caoutchouc et, si présents, les trous sur les bouchons d'évent.
- Pour les groupes avec bouchons d'huile, remplacer le bouchon, utilisé lors de l'expédition, par le bouchon d'évent.
- Contrôler, grâce au voyant (si prévu), que le niveau du lubrifiant corresponde.
- La mise en marche doit s'effectuer d'une façon graduelle, en évitant l'application immédiate de la charge maximale.
- Si des organes, des choses ou des matériels pouvant être endommagés par l'éventuelle sortie d'huile, même si limitée, sont présents sous la motorisation, il faut prévoir une protection adéquate.

ES

INSTALACIÓN

Para la instalación del reductor, atenerse a las siguientes indicaciones:

- Para evitar las vibraciones, la fijación sobre la máquina tiene que ser estable.
- Antes del montaje del grupo sobre la máquina, controlar que el sentido de rotación del eje de salida del reductor sea correcto.
- En caso de periodos de almacenamiento muy largos (4/6 meses), si el retén no está sumergido en el lubricante contenido en el grupo, se aconseja su reemplazo porque la goma podría estar pegada al eje o haber perdido las características de elasticidad necesarias para un funcionamiento correcto.
- Siempre que sea posible, proteger el reductor contra los rayos del sol y la intemperie.
- Controlar que la refrigeración del motor sea suficiente, asegurando una correcta transferencia de aire del lado ventilador.
- En caso de temperatura ambiente de <-5°C o >+40°C, ponerse en contacto con el Servicio técnico.
- El montaje de distintos órganos (poleas, ruedas dentadas, acoplamientos, ejes, etc.) sobre los ejes llenos o huecos debe ser efectuado utilizando los agujeros roscados correspondientes u otros sistemas, asegurando de todas maneras una operación correcta sin correr el riesgo de dañar los cojinetes o las partes externas de los grupos. Lubricar las superficies en contacto para evitar los gripados o las oxidaciones.
- La pintura no debe cubrir las partes de goma y los agujeros de los posibles tapones-respiraderos.
- Para los grupos equipados de tapones de aceite, reemplazar el tapón cerrado, utilizado durante el transporte, por el tapón respiradero.
- Controlar el correcto nivel de lubricante mediante la mirilla (si la hay).
- La puesta en marcha se debe producir de manera gradual evitando la aplicación súbita de la carga máxima.
- Si bajo el reductor hay mecanismos, cosas o materiales que puedan dañarse por una eventual pérdida de aceite, deberá preverse una protección adecuada.

DE QUERBELASTUNGEN - TECHNISCHE BESCHREIBUNGEN

Der Wert der zulässigen Querbelastung (N) wird in den Tabellen über die Leistungen des betreffenden Getriebes aufgeführt und ist die Kraft, die auf die Mittellinie der Wellen unter ungünstigsten Bedingungen wie Anwendungswinkel und Drehrichtung einwirkt.

Die zulässigen Axialbelastungen betragen 1/5 der aufgeführten Querbelastungen, wenn diese gleichzeitig einwirken.

Die Tabellen über die Abtriebswellen geben den für die Lager bzw. das Gehäuse zulässigen Höchstwert an; dieser Wert darf nie überschritten werden.

Falls die im Katalog aufgeführten Grenzwerte doch überschritten werden sollen, setzen Sie sich bitte mit unserem Kundendienst in Verbindung und nennen Sie ihm alle Anwendungsdaten wie Belastungsrichtung, Drehrichtung der Welle, Anwendungsart.

Sofern die Anwendung mit einer beidseitigen Einleitung der Querkraft arbeitet, ist die Anwendung hinsichtlich der Einsatzbedingungen zu überprüfen. Hierzu kontaktieren Sie bitte unser technisches Büro.

Querbelastungen

Die Querbelastung (Querkraft) auf der Welle wird durch nachstehende Formel berechnet:

$$F_{RXL} = \frac{2000 \cdot M_2 \cdot f_z}{d_0} \leq F_{R1} \text{ o } F_{R2}$$

F_{RXL} (N)

Resultierende Querkraft

M₂ (Nm)

Wellendrehmoment

d₀ (mm)

Durchmesser des an der Welle montierten Antriebselements

F_R (N)

Max. zul. Querkraft (siehe entspr. Tafel)

- fz =** 1,1 Zahnrad
1,4 Rad für Kette
1,7 Flanschscheibe
2,5 Flachriemenscheibe

Wenn die Querkraft nicht auf die Mitte der Welle bezogen ist, ist die effektive Kraft durch nachstehende Formel zu berechnen:

$$F_{RX} = \frac{F_{R1-2} \cdot z}{(y + x)}$$

y, z = siehe Tabellen auf Seite 22
x = Abstand der Querkraft zur Wellenschulter

EN RADIAL LOADS - TECHNICAL DESCRIPTIONS

The value of the admissible radial load (N) is given in the tables relating to the performance of the reduction unit at its use. It is related to the load applied on the centre line of the shaft and in the most unfavourable conditions of angle of application and direction of rotation.

The maximum admissible axial loads are 1/5 of the value of the given radial load when they are applied in combination with the radial load.

The tables relating to the output shafts give the maximum admissible value. This value must never be exceeded since it relates to the strength of the case.

Particular conditions of radial load higher than the limits of the catalogue may occur. In this case, call our Technical Service and provide details on the application: direction of the load, direction of rotation of the shaft, type of service.

In case of double extension shafts with radial load applied on both ends, the max. admissible radial loads must be defined according to the specific running conditions, in this case call our Technical Service.

Radial Loads

The radial load on the shaft is calculated with the following formula:

$$F_{RXL} = \frac{2000 \cdot M_2 \cdot f_z}{d_0} \leq F_{R1} \text{ o } F_{R2}$$

F_{RXL} (N)

Resulting radial load

M₂ (Nm)

Torque on the shaft

d₀ (mm)

Diameter of the transmission member mounted on the shaft

F_R (N)

Value of the maximum admitted radial load **F_{R1} - F_{R2}** (see relative tables).

- fz =** 1,1 gear pinion
1,4 chain wheel
1,7 v-pulley
2,5 flat pulley

When the resulting radial load is not applied on the centre line of the shaft it is necessary to calculate the effective load with the following formula:

$$F_{RX} = \frac{F_{R1-2} \cdot z}{(y + x)}$$

a, b, = values given in the tables on page 22
x = distance from the point of application of the load to the shaft shoulder

IT CARICHI RADIALI - DESCRIZIONI TECNICHE

Il valore del carico radiale (N) ammissibile viene riportato nelle tabelle relative alle prestazioni del riduttore in esame, ed è relativo al carico applicato sulla mezzeria dell'albero e nelle condizioni più sfavorevoli come angolo di applicazione e senso di rotazione.

I carichi assiali massimi ammissibili sono 1/5 del valore del carico radiale indicato quando sono applicati in combinazione col carico radiale stesso.

Nelle tabelle relative agli alberi di uscita viene indicato il valore massimo ammissibile, questo valore non deve mai essere superato in quanto è relativo alla resistenza della cassa. Possono essere verificate condizioni particolari di carico radiale superiori ai limiti di catalogo, in questo caso contattare il ns. Servizio Tecnico.

Servizio Tecnico e fornire tutti i dati applicativi: direzione del carico, senso di rotazione dell'albero, tipo di servizio.

Nel caso di alberi bisporgenti e cavi in cui è previsto l'applicazione di carichi radiali su entrambe le estremità, i carichi massimi ammissibili sono da definire in funzione delle condizioni di esercizio specifiche, in questo caso contattare il ns. Servizio Tecnico.

Carichi Radiali

Il carico radiale sull'albero si calcola con la seguente formula:

$$F_{RXL} = \frac{2000 \cdot M_2 \cdot f_z}{d_0} \leq F_{R1} \text{ o } F_{R2}$$

F_{RXL} (N)

Carico radiale risultante

M₂ (Nm)

Momento torcente sull'albero

d₀ (mm)

Diametro dell'elemento di trasmissione montato sull'albero

F_R (N)

Valore di carico radiale massimo ammesso **F_{R1} - F_{R2}** (ved. tab. relative)

- fz =** 1,1 Pignone dentato
1,4 Ruota per catena
1,7 Puleggia a gola
2,5 Puleggia piana

Quando il carico radiale risultante è applicato in mezzeria dell'albero occorre correggere il carico radiale ammissibile **F_{R1-2}** con la seguente formula:

$$F_{RX} = \frac{F_{R1-2} \cdot z}{(y + x)}$$

a, b = Valori riportati nelle tabelle pag. 22
x = distanza del punto di applicazione del carico da spallamento albero

FR

**CHARGES RADIALES -
DESCRIPTIONS TECHNIQUES**

La valeur de la charge radiale (N) admissible est indiquée dans les tableaux concernant les performances du réducteur examiné et correspond à la charge appliquée sur la ligne médiane de l'arbre, dans les conditions les plus défavorables au niveau de l'angle d'application et du sens de rotation.

Les charges axiales maximales admissibles sont 1/5 de la valeur de la charge radiale indiquée, au cas où elles seraient appliquées en combinaison avec la charge radiale même.

Les tableaux concernant les arbres de sortie indiquent la valeur maximale admissible, valeur qui ne doit jamais être dépassée car elle correspond à la résistance de la carcasse. Des conditions particulières de charges radiales supérieures aux limites de catalogue peuvent être vérifiées; dans ce cas, contacter notre Service Technique en donnant toutes les données d'application: direction de la charge, sens de rotation de l'arbre, type de service.

Dans le cas d'arbre double avec une charge radiale appliquée aux deux extrémités, la charge radiale maximale admissible doit être définie selon les conditions de fonctionnement spécifiques, dans ce cas contacter notre service technique.

Charges Radiales

La charge radiale sur l'arbre doit être calculée selon la formule suivante:

$$F_{RXL} = \frac{2000 \cdot M_2 \cdot f_z}{d_0} \leq F_{R1} \text{ o } F_{R2}$$

F_{RXL} (N)

Charge radiale résultante

M₂ (Nm)

Moment de torsion sur l'arbre

d₀ (mm)

Diamètre de l'élément de transmission monté sur l'arbre

F_R (N)

Valeur de charge radiale maximum admise (voir tableaux correspondants)

fz = 1,1 pignon denté
1,4 roue pour chaîne
1,7 poulie à gorge
2,5 poulie plate

Lorsque la charge radiale résultante n'est pas appliquée sur la ligne médiane de l'arbre, il faut calculer celle effective selon la formule suivante:

$$F_{RX} = \frac{F_{R1-2} \cdot z}{(y + x)}$$

y, z = valeurs indiquées dans les tableaux à page 22.

x = distance entre le point d'application de la charge et l'épaulement de l'arbre

ES

**CARGAS RADIALES -
DESCRIPCIONES TECNICAS**

El valor de carga radial (N) admisible es las indicado en las tablas relacionadas a las prestaciones del reductor examinado y se refiere a la carga aplicada sobre la línea de centro del eje y en las condiciones más desfavorables como ángulo de aplicación y sentido de rotación.

Las cargas axiales máximas admisibles son 1/5 del valor de carga radial indicado, cuando están aplicadas en combinación con la carga radial misma.

En las tablas relacionadas a los ejes desalida se indica el valor máximo admisible; nunca se debe superar este valor, porque se refiere a la resistencia de la carcasa.

Podrían presentarse condiciones particulares de carga radial superiores a los límites de catálogo; en este caso, ponerse en contacto con nuestro Servicio técnico e indicar todos los datos de la aplicación: dirección de carga, sentido de rotación del eje, tipo de servicio. En caso de ejes dobles o huecos sobre los que se prevea la aplicación de cargas radiales sobre ambos extremos, las cargas máximas admisibles se deben definir en función de las características de la aplicación, en ese caso contactar a nuestro Servicio Técnico.

Cargas Radiales

La carga radial sobre el eje se calcula con la siguiente fórmula:

$$F_{RXL} = \frac{2000 \cdot M_2 \cdot f_z}{d_0} \leq F_{R1} \text{ o } F_{R2}$$

F_{RXL} (N)

Carga radial resultante

M₂ (Nm)

Par de torsión sobre el eje

d₀ (mm)

Diametro del elemento de transmisión montado sobre el eje

F_R (N)

Valor de carga radial máximo admitido (ver tablas correspondientes)

fz = 1,1 Piñon dentado
1,4 Piñon de cadena
1,7 Polea para correa trapezoidal
2,5 Polea plana

Si la carga radial resultante no está aplicada sobre la línea da centro del eje, es necesario calcular la efectiva con la siguiente fórmula:

$$F_{RX} = \frac{F_{R1-2} \cdot z}{(y + x)}$$

y, z = valores indicados en las tablas pág.22

x = distancia desde el punto de aplicación de la carga hasta la base del eje

DE QUERBELASTUNGEN - TECHNISCHE BESCHREIBUNGEN
FR CHARGES RADIALES - DESCRIPTIONS TECHNIQUES

EN RADIAL LOADS - TECHNICAL DESCRIPTIONS
ES CARGAS RADIALES - DESCRIPCIONES TECNICAS

IT CARICHI RADIALI - DESCRIZIONI TECNICHE

Abtriebswellen

Sofern die radiale Querkraft nicht auf die Mitte der Welle bezogen ist, ist die effektive zulässige Kraft F_{RX2} durch folgende Formel zu berechnen:

Arbres de Sortie

Quand la charge radiale n'est pas au milieu de l'arbre, il est nécessaire de corriger la charge radiale admissible F_{RX2} avec la formule suivante:

Output Shafts

When the radial load is not on the centre line of the shaft, it is necessary to adjust the admissible radial load F_{RX2} with the following formula:

Ejes de Salida

Si la carga radial resultante no se aplica sobre el centro del eje, corregir la carga radial admissible F_{RX2} mediante la siguiente fórmula:

Alberi in Uscita

Con carico radiale risultante non in mezzeria dell'albero, correggere il carico radiale ammissibile F_{RX2} con la formula:

K	35390	40390	50390	60390	70390	90390	100390
z	129	190	225	262	306	348	468
y	100	150	175	202	236	278	363
F_{R2} (a) max**	12000	18000	22000	30000	40000	65000	80000
F_{R2} (b) max**	8000	12000	15000	20000	40000	65000	65000

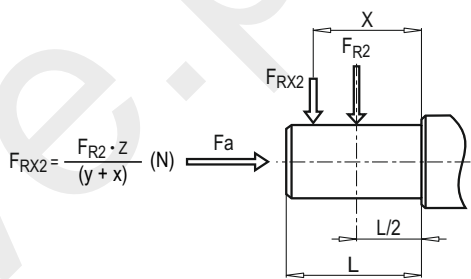

(** F_{R2}) Entspricht dem max. zulässigen Getriebewert; bitte beachten sie den max. Wert de Tabelle.
 (** F_{R2}) Max. admissible value of the reducer; verify max. admissible value on performance tables.
 (** F_{R2}) Valore massimo ammesso dal riduttore; verificare valore massimo ammesso su tabelle di prestazioni.
 (** F_{R2}) Valeur maximale admissible du réducteur; vérifier la valeur maxi admissible dans les tableaux de performances.
 (** F_{R2}) Valor máximo admisible por el reductor; verificar el valor máximo admisible en las tablas de preestaciones.

Abtriebswellen

Sofern die radiale Querkraft nicht auf die Mitte der Welle bezogen ist, ist die effektive zulässige Kraft F_{RX1} durch folgende Formel zu berechnen:

Arbres de Sortie

Quand la charge radiale n'est pas au milieu de l'arbre, il est nécessaire de corriger la charge radiale admissible F_{RX1} avec la formule suivante:

Input Shafts

When the radial load is not on the centre line of the shaft, it is necessary to adjust the admissible radial load F_{RX1} with the following formula:

Ejes de Salida

Si la carga radial resultante no se aplica sobre el centro del eje, corregir la carga radial admissible F_{RX1} mediante la siguiente fórmula:

Alberi in Uscita

Con carico radiale risultante non in mezzeria dell'albero, correggere il carico radiale ammissibile F_{RX1} con la formula:

K	35390	40390	50390	60390	70390	90390	100390
z	105	137	137	175	175	225	221
y	80	108	108	135	135	170	166
F_{R1} max**	2200	2500	3200	4200	7000	10000	12000

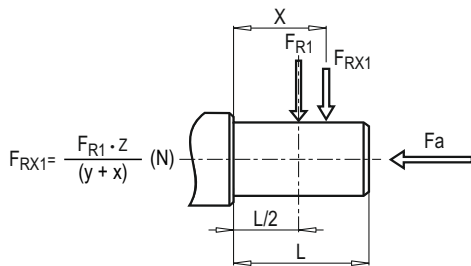

(** F_{R1}) Entspricht dem max. zulässigen Getriebewert; bitte beachten sie den max. Wert de Tabelle.
 (** F_{R1}) Max. admissible value of the reducer; verify max. admissible value on performance tables.
 (** F_{R1}) Valore massimo ammesso dal riduttore; verificare valore massimo ammesso su tabelle di prestazioni.
 (** F_{R1}) Valeur maximale admissible du réducteur; vérifier la valeur maxi admissible dans les tableaux de performances.
 (** F_{R1}) Valor máximo admisible por el reductor; verificar el valor máximo admisible en las tablas de preestaciones.

DE MASSETRÄGHEITMOMENTE

Die angegebenen Werte sind Richtwerte und beziehen sich auf Getriebe mit PAM Eingangsflansch.
Die angegebenen Werte beziehen sich jeweils auf das max. Massenträgheitsmoment.

EN MOMENTS OF INERTIA

Following values are indicative only and refer to gear reducers fitted with input PAM.
These values refer to maximum moment of inertia.

IT MOMENTI D'INERZIA

I seguenti valori sono solo indicativi. Sono riferiti a riduttori già predisposti con l'attacco motore PAM.
I valori in tabelle sono riferiti al massimo di quelli calcolati.

FR MOMENTS D'INERTIE

Les valeurs suivantes sont seulement indicatives et se rapportent à des réducteurs de vitesse équipés avec l'entrée PAM.
Ces valeurs sont relatives au moment d'inertie maximum.

ES MOMENTOS DE INERCIA

Los valores siguientes son sólo indicativos y se refieren a los reductores con PAM de entrada.
Estos valores están referidos al momento de inercia máximo.

K...	J · 1E - 4 [Kg · m ²]
K 35390	1.1
K 40390	2.5
K 50390	7.0
K 60390	10.4
K 70390	23.0
K 90390	34.8
K 100390	92.9

DE SCHMIERUNG

Bei in der Tafel nicht vorgesehenen Umgebungstemperaturen setzen Sie sich bitte mit unserem Kundendienst in Verbindung.

Bei Temperaturen unter -30°C oder über 60°C werden Dichtringe aus besonderen Elastomeren benötigt.

Bei Betrieb mit Temperaturen unter 0°C ist folgendes zu berücksichtigen:

- 1- Die Motoren müssen für den Betrieb mit der vorgesehenen niedrigen Raumtemperatur geeignet sein.
- 2- Die Leistung des Elektromotors muß so ausgelegt werden, dass die höheren benötigten Anlaufdrehmomente aufgebracht werden können.
- 3- Bei Getriebeghäusen aus Guß sind die Stoßbelastungen zu beachten, weil der Guß bei Temperaturen unter -15°C verspröden könnte.
- 4- Bei Betriebsbeginn könnten Schmierungsprobleme infolge der hohen Ölviskosität auftreten, daher ist es sinnvoll, für einige Minuten einen Leerlauf auszuführen. Je nach Umgebungsbedingungen und Betriebsart ist nach etwa 10.000 Betriebsstunden ein Ölwechsel durchzuführen. Die Getriebe ohne Ölstopfen sind langzeitgeschmiert und benötigen daher keine weiteren Wartungsarbeiten.

EN LUBRICATION

In cases of ambient temperatures not envisaged in the table, call our Technical Service.

In the case of temperatures under -30°C or over 60°C it is necessary to use oil seals with special properties.

For operating ranges with temperatures under 0°C it is necessary to consider the following:

- 1- The motors need to be suitable for operation at the envisaged ambient temperature.
- 2- The power of the electric motor needs to be adequate for exceeding the higher starting torques required.
- 3- In case of cast-iron gear reducers, pay attention to impact loads since cast iron may have problems of fragility at temperatures under -15°C.
- 4- During the early stages of service, problems of lubrication may arise due to the high level of viscosity taken on by the oil and so it is wise to have a few minutes of rotation under no load.

The oil needs to be changed after approximately 10,000 hours. This period depends on the type of service and the environment where the reduction unit works. For unit supplied without oil plugs, lubrication is permanent and so they need no servicing.

IT LUBRIFICAZIONE

Nei casi con temperature ambiente non previste in tabella contattare il ns. Servizio Tecnico.

In caso di temperature inferiori a -30°C o superiori a 60°C occorre utilizzare anelli di tenuta con mescole speciali.

Per i campi di funzionamento con temperature inferiori a 0°C occorre considerare quanto segue:

- 1- I motori devono essere idonei al funzionamento con temperatura ambiente prevista.
- 2- La potenza del motore elettrico deve essere adeguata al superamento delle maggiori coppie di avviamento richieste.
- 3- Nel caso di riduttori con cassa in ghisa prestare attenzione ai carichi d'urto in quanto la ghisa può presentare problemi di fragilità a temperature inferiori ai -15°C.
- 4- Durante le prime fasi di servizio possono insorgere problemi di lubrificazione cause l'elevata viscosità che assume l'olio e quindi è opportuno procedere ad alcuni minuti di rotazione a "vuoto".

Il cambio olio deve essere eseguito dopo circa 10.000 ore, questo periodo è in funzione del tipo di servizio e dell'ambiente in cui opera il riduttore. Per i gruppi forniti senza tappi per l'olio la lubrificazione si intende permanente e quindi non hanno necessità di alcuna manutenzione.

FR LUBRIFICATION

En cas de températures ambiantes non prévues dans le tableau, contacter notre S. ce Technique.

En cas de température au-dessous de -30°C ou au-dessus de 60°C, il faut utiliser des bagues d'étanchéité avec mélanges spéciaux.

Pour les champs de fonctionnement avec température au-dessus de 0°C, il faut considérer ce qui suit:

- 1- Les moteurs doivent être aptes au fonctionnement à la température ambiante prévue.
- 2- La puissance du moteur électrique doit être au dépassement de la plupart des couples de démarrage demandés.
- 3- En cas de réducteurs avec carcasse en fonte, faire attention aux charges de choc, car la fonte peut présenter des problèmes de fragilité à températures au-dessous de -15°C.
- 4- Lors des premières phases de service, des problèmes de lubrification dus à la viscosité élevée, que l'huile assume, pourraient se vérifier; il faut donc procéder à une rotation "à vide" de quelques minutes.

Le changement d'huile doit être effectué après 10,000 heures environ; cette période est en fonction du type de service et du milieu dans lequel le réducteur travaille. Pour les groupes livrés sans bouchons d'huile, la lubrification est permanente et ils ne nécessitent donc aucun entretien.

ES LUBRICACIÓN

En caso de temperaturas no previstas en la tabla, ponerse en contacto con nuestro Servicio técnico.

En caso de temperaturas inferiores a -30°C o superiores a 60°C, es necesario utilizar anillos de retén con mezclas especiales. Para los campos de funcionamiento con temperaturas inferiores a 0°C, es necesario cumplir con lo que sigue:

- 1- Los motores tienen que ser idóneos al funcionamiento con la temperatura ambiente prevista.
- 2- La potencia del motor eléctrico tiene que ser idónea para superar los mayores pares de arranque pedidos.
- 3- En caso de reductores con carcasa de fundición, cuidado con las cargas de choque porque la fundición puede presentar problemas de fragilidad con temperaturas inferiores a los -15°C.
- 4- Durante las primeras fases de servicio podrían surgir unos problemas de lubricación debidos a la elevada viscosidad del aceite y es por lo tanto oportuno efectuar una rotación en "vacío" por algunos minutos.

El cambio de aceite tiene que ser efectuado aproximadamente después de 10.000 horas; claramente, este periodo es en función del tipo de ambiente en el que trabaja el reductor. En los grupos entregados sin tapones, el lubricante es permanente y por lo tanto no necesitan ningún mantenimiento.

DE SCHMIERUNG
FR LUBRIFICATION

EN LUBRICATION
ES LUBRICACIÓN

IT LUBRIFICAZIONE

Mineralöl / Mineral Oil / Olio Minerale / Huile Minérale / Aceite Mineral							
	T°C ISO SAE...	ENI	SHELL	ESSO	MOBIL	CASTROL	BP
K 35390-100390	(-5) / (+40) ISO VG220	BLASIA 220	OMALA OIL220	SPARTAN EP220	MOBILGEAR 600 XP220	ALPHA MAX 220	ENERGOL GR-XP220
	(-15) / (+25) ISO VG150	BLASIA 150	OMALA OIL150	SPARTAN EP150	MOBILGEAR 600 XP150	ALPHA MAX 150	ENERGOL GR-XP150

- Spezifische Schmierstoffangaben erfragen Sie bei NRW Drive Technologies.
- Specifications of lubricants recommended by NRW Drive Technologies.
- Specifiche dei lubrificanti consigliati da NRW Drive Technologies.
- Especificaciones de lubricante aconsejados por NRW Drive Technologies.
- Spécification des lubrifiants suivant NRW Drive Technologies.

- Für die Ölmengen siehe Seite 26.
- For the quantity of oil, please refer to the pages relating. (page 26)
- Per le quantità di olio si rimanda alle pagine relative. (pagina 26)
- Pour les quantités d'huile, voir pages concernant. (page 26)
- Para las cantidades de aceite, ver a las páginas. (página 26)

Spezialschmierstoffe / Special lubricants / Lubrifiants spéciaux / Lubricantes especiales			
		*T°C	Synthetisches Öl / Synthetic oil / Olio sintetico / Huile synthétique / Aceite sintetico
Öle für niedrige Temperaturen Oils for low temperature Oli per basse temperature Huiles pour basse température Aceites para bajas temperaturas	ENI	(-25) ÷ (+20)	BLASIA 150 S (ISO VG150)
	KLUBER	(-35) ÷ (+10)	KLUBERSYNTH GH 6-80 (ISO VG68)
	MOBIL	(-40) ÷ (+5)	SCH 624 (ISO VG32)
	KLUBER	(-40) ÷ (+5)	KLUBERSYNTH GH 6-32 (ISO VG32)
Öle für niedrige Temperaturen - Lebensmittelsektor Oils for low temperature - Food sector Oli per basse temperature - Settore alimentare Huiles pour basse température - Secteur de l'alimentation Aceites para bajas temperaturas - Sector alimentario	KLUBER	(-30) ÷ (+10)	KLUBERSYNTH UH1-6 100 (ISO VG100)
Öle für hohe Temperaturen / Oils for high temperature / Oli per alte temperature / Huiles pour haute température / Aceites de alta temperatura	KLUBER	(-10) ÷ (+50)	KLUBERSYNTH GH 6-460 (ISO VG460)
	KLUBER	(-10) ÷ (+70)	KLUBERSYNTH GH 6-680 (ISO VG680)
Öle für hohe Temperaturen - Lebensmittelsektor Oils for high temperature - Food sector Oli per alte temperature - Settore alimentare Huiles pour haute température - Secteur de l'alimentation Aceites de alta temperatura - Sector alimentario /	KLUBER	(-15) ÷ (+40)	KLUBERSYNTH UH1-6 460 (ISO VG460)
Lebensmittelsektor / Food sector / Settore alimentare / Secteur de l'alimentation / Sector alimentario	KLUBER	(-15) ÷ (+40)	KLUBERSYNTH UH1-6 220 (ISO VG220)

Falls spezielles Öl verwendet werden soll kontaktieren sie bitte unseren Kundendienst
If 'special' lubricant is required please contact for Technical Assistance
Per l'utilizzo di lubrificanti speciali, contattare l'assistenza tecnica
Si un Lubrifiant spécial est demandé, merci de contacter notre service technique.
Para el uso de lubricantes especiales contactar con la asistencia técnica

* Betriebsumgebungstemperatur
* Working ambient temperature
* Temperatura ambiente di funzionamento
* Température ambiante de fonctionnement
* Temperatura ambiente de funcionamiento

DE SCHMIERUNG

- Für die Getriebe der Serie K ist die Einbaulage anzugeben.
 - K 35390, werden mit Schmiermittel befüllt geliefert. Die Getriebe bedürfen keinerlei Wartung und sind werkseitig mit einem Verschlussstopfen versehen.
 - Die Getriebe der Serie K in den Baugrößen 40390, 50390, 60390, 70390, 90390, 100390 werden werkseitig mit Schmieröl, sowie Ölstopfen ausgeliefert.
 Die erforderliche Ölmenge und die Positionen der Ölschaugläser entsprechen der werkseitig vorgeschlagenen Position.
 Vor der Inbetriebnahme sind die Verschlussstopfen, durch entsprechende Entlüftungsventile, gemäß der Einbaulage, auszutauschen.
 Die angegebenen Ölmenngen sind Richtwerte. Diese müssen je nach Einbaulage, über Ölschaugläser, Ölstandsbohrungen der Ölmesstäbe (je nach Typ) regelmäßig überprüft werden.
 Ölstandsunterschiede können aus verschiedenen Einbaulagen bei Applikationen resultieren. Nach jeder Montage, sind alle Ölstände zwingend zu prüfen und gegebenenfalls anzupassen.

EN LUBRICATION

- For the reduction units K series it is always necessary to specify the mounting position.
 - K 35390, are supplied complete with lubricant, have no oil plugs and need no maintenance
 - The gear reducer K series sizes 40390, 50390, 60390, 70390, 90390, 100390 are supplied complete with lubricant and are fitted with oil plugs to suit any mounting position included in the catalogue.
 It is recommended, after installation, to replace the closed plug used for transportation with the supplied breather plug. Lubricant quantities are only indicative, For correct filling always refer to the sight glass or the dipstick, when this is supplied.
 Any oil level differences can be caused by constructive tolerances but also on the mounting position or the assembly scheme of the customer Therefore it is very important for the customer to check oil level and if necessary to add the necessary quantity.

IT LUBRIFICAZIONE

- Per i riduttori serie K occorre sempre specificare la posizione di piazzamento prevista.
 - K35390, vengono forniti completi di lubrificante sono sprovvisti dei tappi olio e non hanno necessità di alcuna manutenzione
 - I riduttori serie K nelle grandezze 40390, 50390, 60390, 70390, 90390, 100390 vengono forniti completi di lubrificante a dei tappi olio necessari a garantire la corretta lubrificazione nella posizione di piazzamento richiesta.
 Si raccomanda, effettuata l'installazione, di sostituire il tappo chiuso utilizzato per il trasporto con il tappo di sfiato fornito a corredo.
 Le quantità di olio in tabella sono solo indicative e per il corretto riempimento si dovrà fare riferimento al tappo o all'astina di livello, se presente.
 Eventuali scostamenti di livello possono dipendere da tolleranze costruttive ma anche dal piazzamento del riduttore o dal piano di montaggio presso cliente. Per tale motivo è opportuno che il cliente verifichi e, se necessario, ristabilisca il livello a riduttore installato.

FR LUBRIFICATION

- Pour les réducteurs série K il faut toujours spécifier la position de montage.
 - K 35390, sont fournis avec lubrifiant et sans bouchons et ne nécessitent, donc, aucun entretien.
 - Les réducteurs série K pour les grandeurs 40390, 50390, 60390, 70390, 90390, 100390 sont fournis avec tous les bouchons nécessaires pour garantir toutes les positions de montage prévues au catalogue.
 On recommande, après l'installation, de changer le bouchon livré pour le transport contre celui fourni avec trou d'évent.
 Les quantités d'huile indiquées en tableau sont seulement indicatives et pour un remplissage correct il faut faire référence au bouchon de niveau ou à la jauge à huile, si présents.
 Toutes les différences de niveau d'huile peuvent être causées par des tolérances de constructions, ou par la position de montage, ou le schéma d'assemblage du client. Par conséquent il est très important que le client vérifie le niveau d'huile et au besoin ajoute la quantité nécessaire.

ES LUBRICACIÓN

- Para los reductores serie K es necesario especificar siempre la posición de montaje.
 - K 35390, se suministran con lubricante, no disponen de tapón aceite y no necesitan ningún mantenimiento .
 - Los reductores serie K en los tamaños 40390, 50390, 60390, 70390, 90390, 100390 se suministran con lubricante y disponen de tapones para todas las posiciones de montaje previstas en el catálogo.
 Es necesario, una vez instalado el reductor en la máquina, sustituir el tapón cerrado, utilizado durante el transporte, por el tapón respiradero que se adjunta.
 Las cantidades de lubricante en la tabla son indicativas y para un correcto llenado hay que tomar de referencia el centra del visor o del asta de nivel si están instaladas.
 Eventuales diferencias del nivel de aceite pueden depender de tolerancias constructivas perotambién de la posición de montaje o del esquema de montaje del cliente. Por tanto es muy importante que el cliente compruebe el nivel de aceite y si es necesario agregue la cantidad adecuada.

Ölmenge (Liter) / Quantity of oil in litres / Quantità olio in litri / Quantité d'huile en litres / Cantidad de aceite en litros

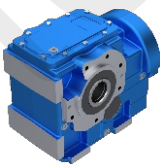
	Typ / Type / Tipo / Type / Tipo	M1	M2	M3	M4	M5	M6
	K 35390	1.40	1.40	1.50	2.00	1.50	1.70
K 40390	2.70	3.30	3.20	4.00	3.50	3.20	
K 50390	4.30	4.50	4.60	6.40	6.00	5.50	
K 60390	6.80	7.50	8.50	9.90	8.50	7.80	
K 70390	13.20	13.00	14.50	19.50	16.50	14.80	
K 90390	22.00	21.50	23.00	31.00	29.00	24.00	
K 100390	33.10	37.40	43.00	54.60	43.10	30.10	

DE EINBAULAGE
FR POS. DE MONTAGE

EN MOUNTING POSITIONS
ES POS. DE MONTAJE

IT PIAZZAMENTO

FLANSCHBEFESTIGUNG

FLANGE MOUNTING
FISSAGGIO FLANGIA
FIXATION À BRIDE
FIJACIÓ N PO R BRIDA

FUß-FLANSCHBEFESTIGUNG

FOOT-FLANGE MOUNTING
FISSAGGIO PIEDE-FLANGIA
FIXATION À PAAES ET BRIDE
FIJACIÓ N PATAS-BRIDA

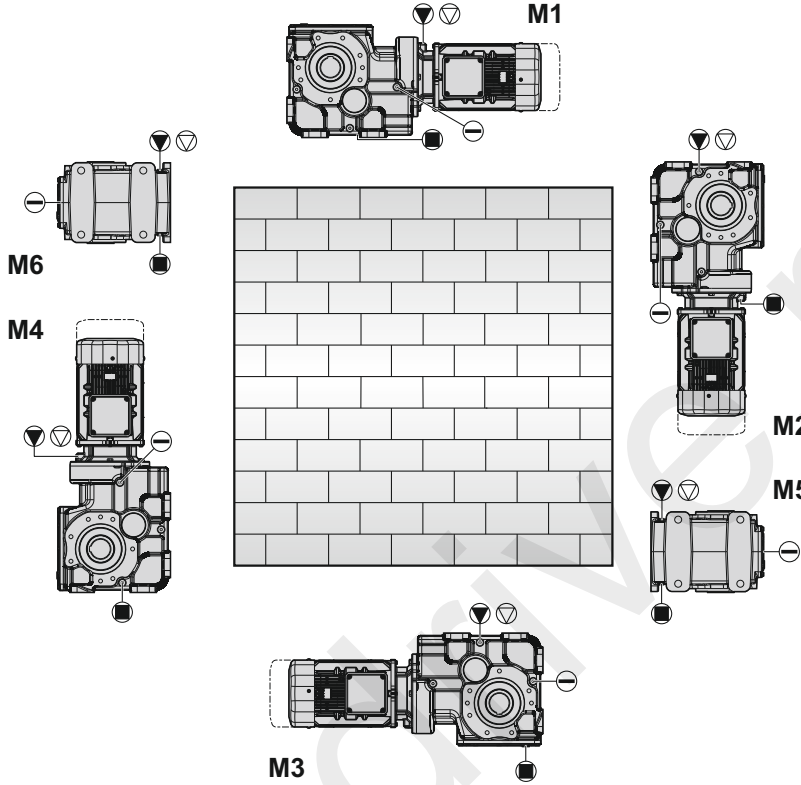

K...AF	K...F
K35390	K35390
K40390	K40390
K50390	K50390
K60390	K60390
K70390	
K90390	
K100390	

K...A
K 40390
K 50390
K 60390

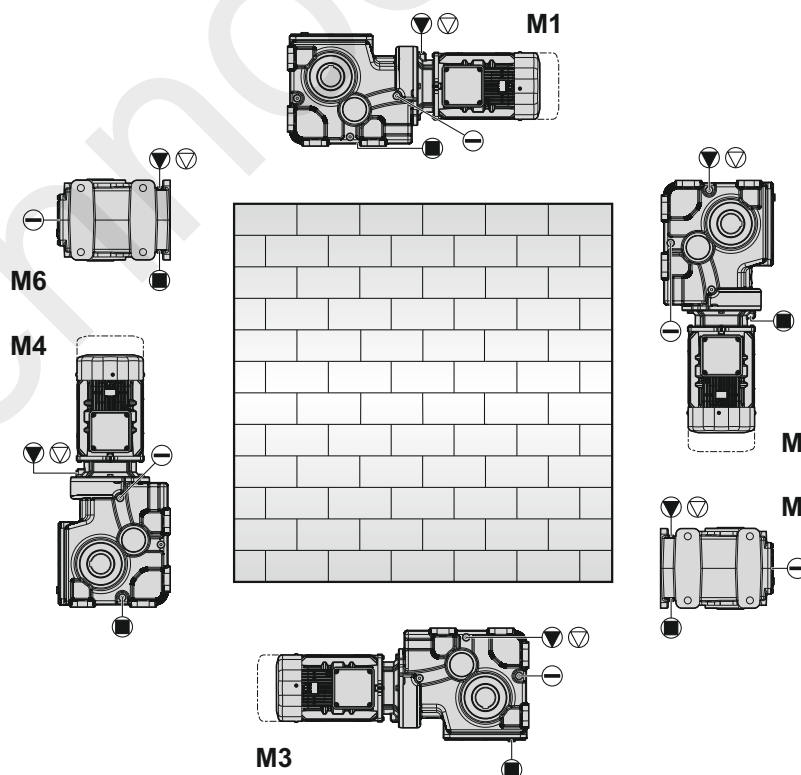

FUßBEFESTIGUNG
FOOT MOUNTING
FISSAGGIO PIEDE
FIXATION À PATTES
FIJACIÓ N POR PATAS

⊕ Entlüftung / Vent plug /
Tappo di sfiato / Évent /
Ventilaci3n

⊖ Einfüllstopfen / Filling plug
Tappo carico / Bouchon remplissage /
Tap3n de carga

⊖ Ölstand / Oil level /
Tappo di livello dell'olio /
Niveau d'huile / Nivel de aceite

● Ölablass / Drain plug /
Tappo di scarico dell'olio /
Vidange d'huile / Vaciado de aceite

DE EINBAULAGE

EN MOUNTING POSITIONS

IT PIAZZAMENTO

Klemmenkastenlage

- Im Falle von Sonderanforderungen ist bei Auftragserteilung die Lage des Klemmenkastens gemäß dem Schema genau anzugeben.
- Sofern nichts gegenteiliges angegeben, wird der Schneckengetriebemotor mit klemmkastenlage 1 geliefert.

Position Of Terminal Box

- In the case of specific requirements, when ordering, specify the position of the terminal box as shown in the diagram.
- Unless other wise specified, the gear reducer is supplied with terminal box in position 1.

Posizione Morsetteria

- Nel caso di particolari esigenze specificare in fase di ordine la posizione della morsetteria come da schema.
- Se non diversamente specificato, il gruppo viene fornito con morsetteria in pos.1.

FR POS. DE MONTAGE

ES POS. DE MONTAJE

Position Du Bornier

- En cas d'exigences particulières, spécifier, lors de la commande, la position du bornier comme d'après le schéma.
- Sauf indications contraires, le réducteur est fourni avec boîte à borne en position 1.

Posición Caja De Bornes

- En caso de exigencias particulares, detallar en el pedido, la posición de la caja de bornes según el esquema.
- Si no esta diferentemente especificado, el motorreductor se monta con la caja de bornes en posición 1.



KLEMMKASTENLAGE UND KABELEINFÜHRUNG / POSITION OF TERMINAL BOX AND CABLE ENTRY / POSIZIONE MORSETTIERA E INGRESSO CAVI / POSITION DE LA BOÎTE À BORNES ET DE L'ENTRÉE DE CÂBLE / POSICIÓN DE LA CAJA DE TERMINALES Y ENTRADA DE CABLES

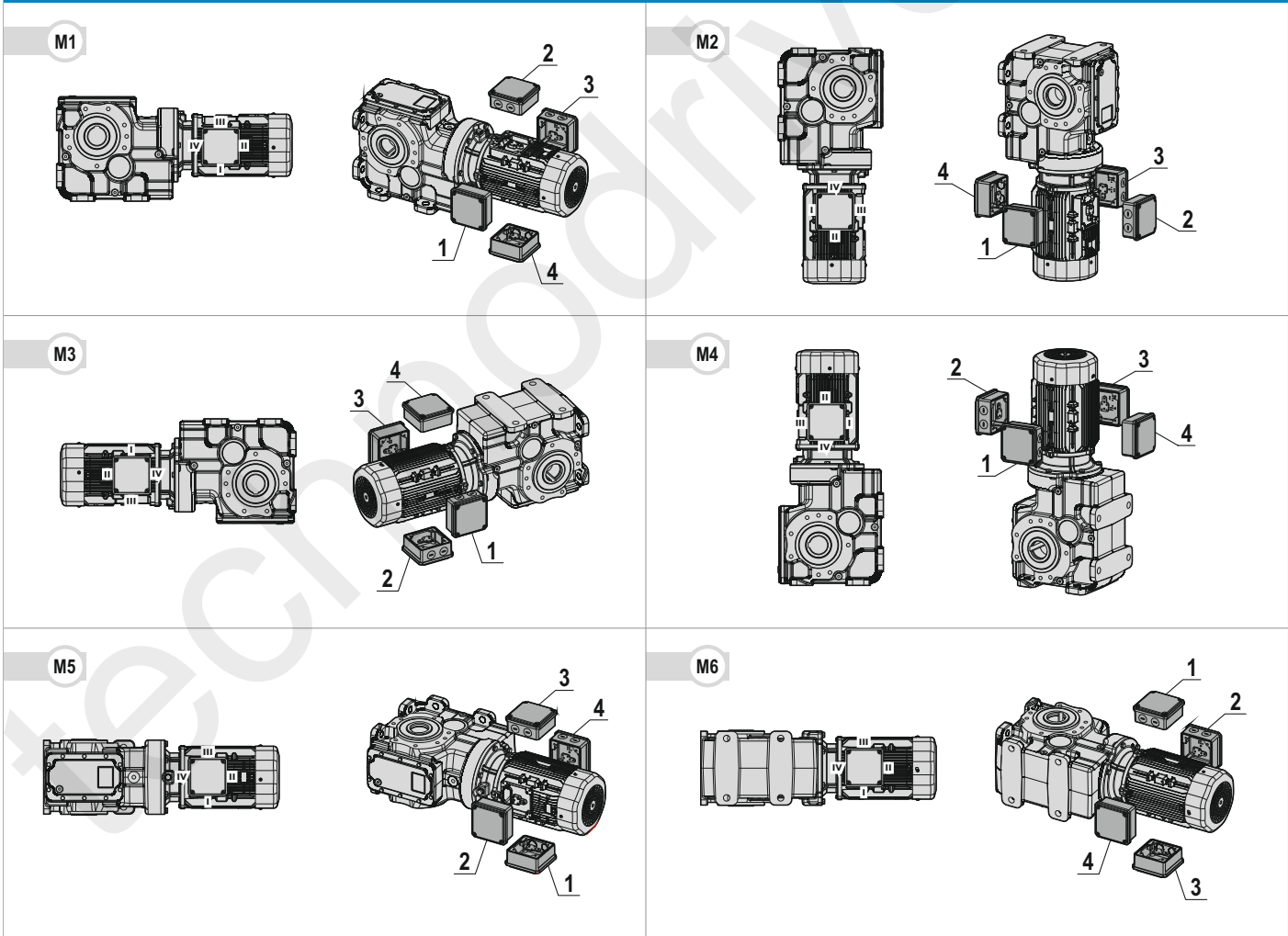

- * 1 - 2 - 3 - 4 : Zeigt die Position des Klemmkastens an
- * 1 - 2 - 3 - 4 : Shows terminal box position
- * 1 - 2 - 3 - 4 : Mostra la posizione della morsetteria
- * 1 - 2 - 3 - 4 : Affiche la position de la boîte à bornes
- * 1 - 2 - 3 - 4 : Muestra la posición de la caja de terminales

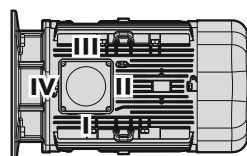

- * I - II - III - IV : Zeigt die kabeleinführungsposition an
- * I - II - III - IV : Shows cable entry position
- * I - II - III - IV : Mostra la posizione di ingresso del cavo
- * I - II - III - IV : Indique la position d'entrée du câble
- * I - II - III - IV : Muestra la posición de entrada del cable

DE EINBAULAGE

- Im Falle von Sonderanforderungen ist bei Auftragserteilung die Lage des Klemmenkastens gemäß dem Schema genau anzugeben.
- Sofern nichts Gegenteiliges angegeben, wird der Schneckengetriebemotor mit Klemmkastenlage 1 geliefert.

EN MOUNTING POSITIONS

- In the case of specific requirements, when ordering, specify the position of the terminal box as shown in the diagram.
- Unless otherwise specified, the gear reducer is supplied with terminal box in position 1.

IT PIAZZAMENTO

- Nel caso di particolari esigenze specificare in fase di ordine la posizione della morsetteria come da schema.
- Se non diversamente specificato, il gruppo viene fornito con morsetteria in pos.1.

FR POS. DE MONTAGE

- En cas d'exigences particulières, spécifier, lors de la commande, la position du bornier comme d'après le schéma.
- Sauf indications contraires, le réducteur est fourni avec boîte à borne en position 1.

ES POS. DE MONTAJE

- En caso de exigencias particulares, detallar en el pedido, la posición de la caja de bornes según el esquema.
- Si no está diferentemente especificado, el motorreductor se monta con la caja de bornes en posición 1.

K-A

KLEMMKASTENLAGE UND KABELINFÜHRUNG / POSIZIONE MORSETTIERA E INGRESSO CAVI / POSIZIONE MORSETTIERA E INGRESSO CAVI / POSITION DE LA BÔÎTE À BORNES ET DE L'ENTRÉE DE CÂBLE / POSICIÓN DE LA CAJA DE TERMINALES Y ENTRADA DE CABLES

M1

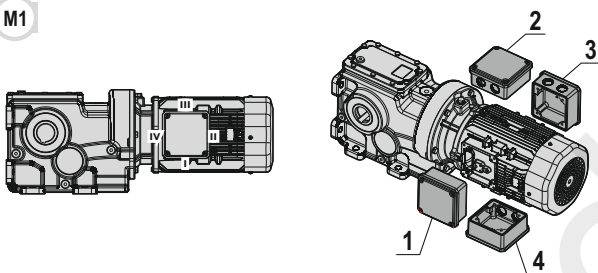

M2

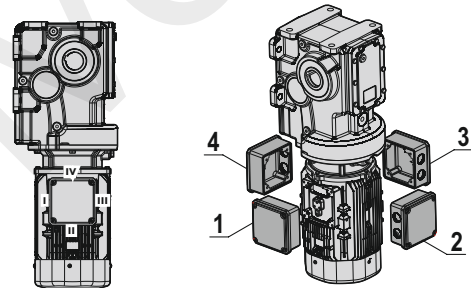

M3

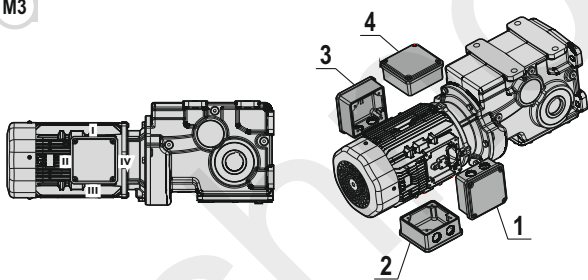

M4

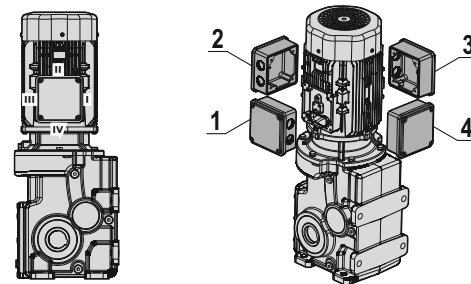

M5

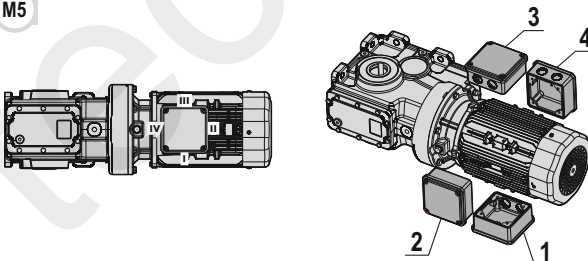

M6

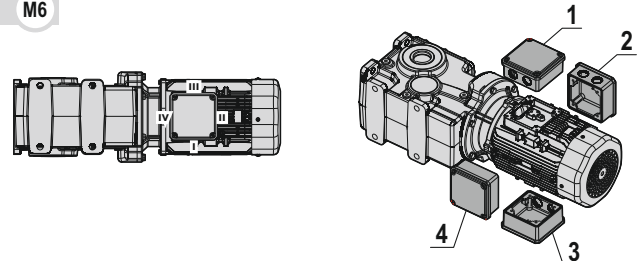

* 1 - 2 - 3 - 4 : Zeigt die Position des Klemmkastens an
* 1 - 2 - 3 - 4 : Shows terminal box position
* 1 - 2 - 3 - 4 : Mostra la posizione della morsetteria
* 1 - 2 - 3 - 4 : Affiche la position de la boîte à bornes
* 1 - 2 - 3 - 4 : Muestra la posición de la caja de terminales

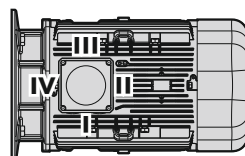

* I - II - III - IV: Zeigt die kabeleinführungsposition an
* I - II - III - IV: Shows cable entry position
* I - II - III - IV: Mostra la posizione di ingresso del cavo
* I - II - III - IV: Indique la position d'entrée du câble
* I - II - III - IV: Muestra la posición de entrada del cable

DE EINBAULAGE

- Für die vertikalen Einbaulagen siehe seite 10-11.
- Falls nicht anders angegeben, sind M1 die standardeinbaulagen.
- Für nicht angegebene Einbaulagen setzen sie sich bitte mit unserem Kundendienst in Verbindung.

EN MOUNTING POSITIONS

- For vertical positions, check with pages 10-11.
- Unless specified otherwise, the standard positions are M1.
- For positions not envisaged, it is necessary to call our Technical Service.

IT PIAZZAMENTO

- Per le posizioni di piazzamento verticali verificare quanto detto a pag. 10-11.
- Se non diversamente specificato le posizioni standard sono M1.
- Per le posizioni di piazzamento non previste occorre rivolgersi al ns. Servizio tecnico.

FR POS. DE MONTAGE

- Pour les positions de montage verticales, voir pages 10 et 11.
- Si non spécifié, les positions standard sont M1.
- Pour les positions de montage non prévues, contacter notre Service technique.

ES POS. DE MONTAJE

- Para las posiciones de montaje verticales, ver las páginas 10-11.
- Si non se especifica el contrario, las posiciones estándar son M1.
- Para las posiciones de montaje no previstas, es necesario ponerse en contacto con nuestro Servicio técnico.

K-DA / TMA / ÇMA

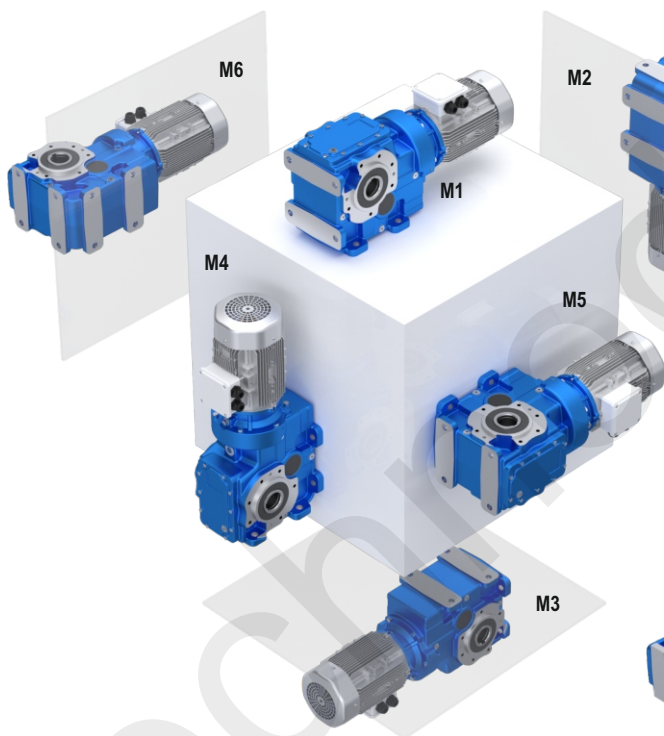

K-DG / TMG / ÇMG

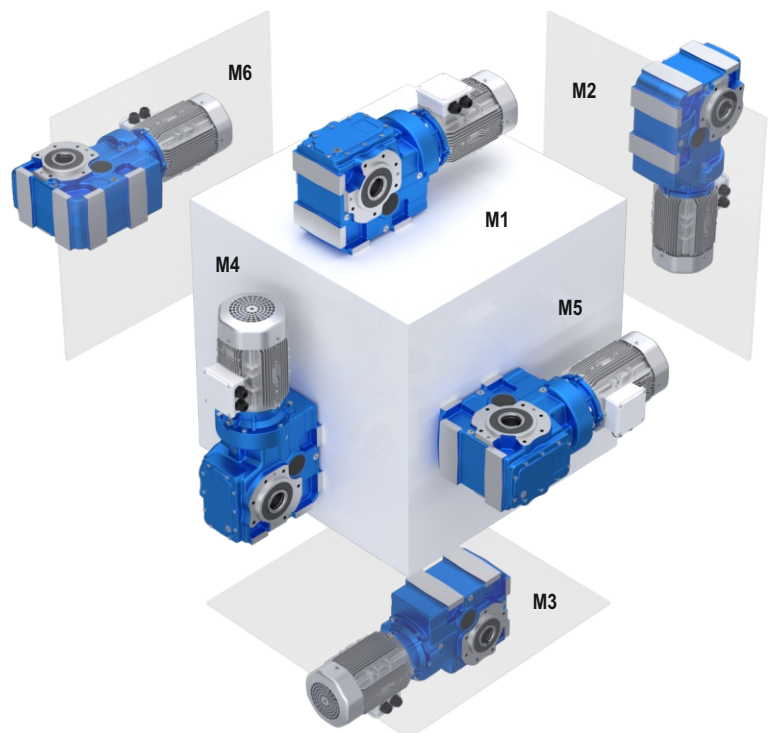

DE MODULARES BAUKASTENSYSTEM

EN MODULARITY

IT MODULARITÀ

FR MODULARITÉ

ES MODULARIDAD

MOTOR

- Ausführungen mit Kompaktelektromotoren.
- Compact electric motor versions.
- Versioni con motore elettrico compatto.
- Version avec moteur électrique compact.
- Versión motorreductor compacto.

PAM

- Ausführungen zum Anbau von PAM - Motoren.
- Fitted for motor coupling version (PAM).
- Versione con predisposizione per attacco motore PAM.
- Version avec prédisposition pour moteur PAM.
- Versión motorreductor (PAM).

IEC

- Die Verbindung Motor Getriebe erfolgt über Kupplung.
- Fitted for motor mounting with flexible coupling.
- Predisposto per attacco motore con giunto.
- Prédisposé pour montage moteur avec joint.
- Predisposto para montaje motor con acoplamiento.

W

- Ausführungen mit Antriebsvollwelle.
- Input shaft versions.
- Versioni con albero maschio in ingresso.
- Version avec arbre en entrée.
- Versión con eje macho de entrada.

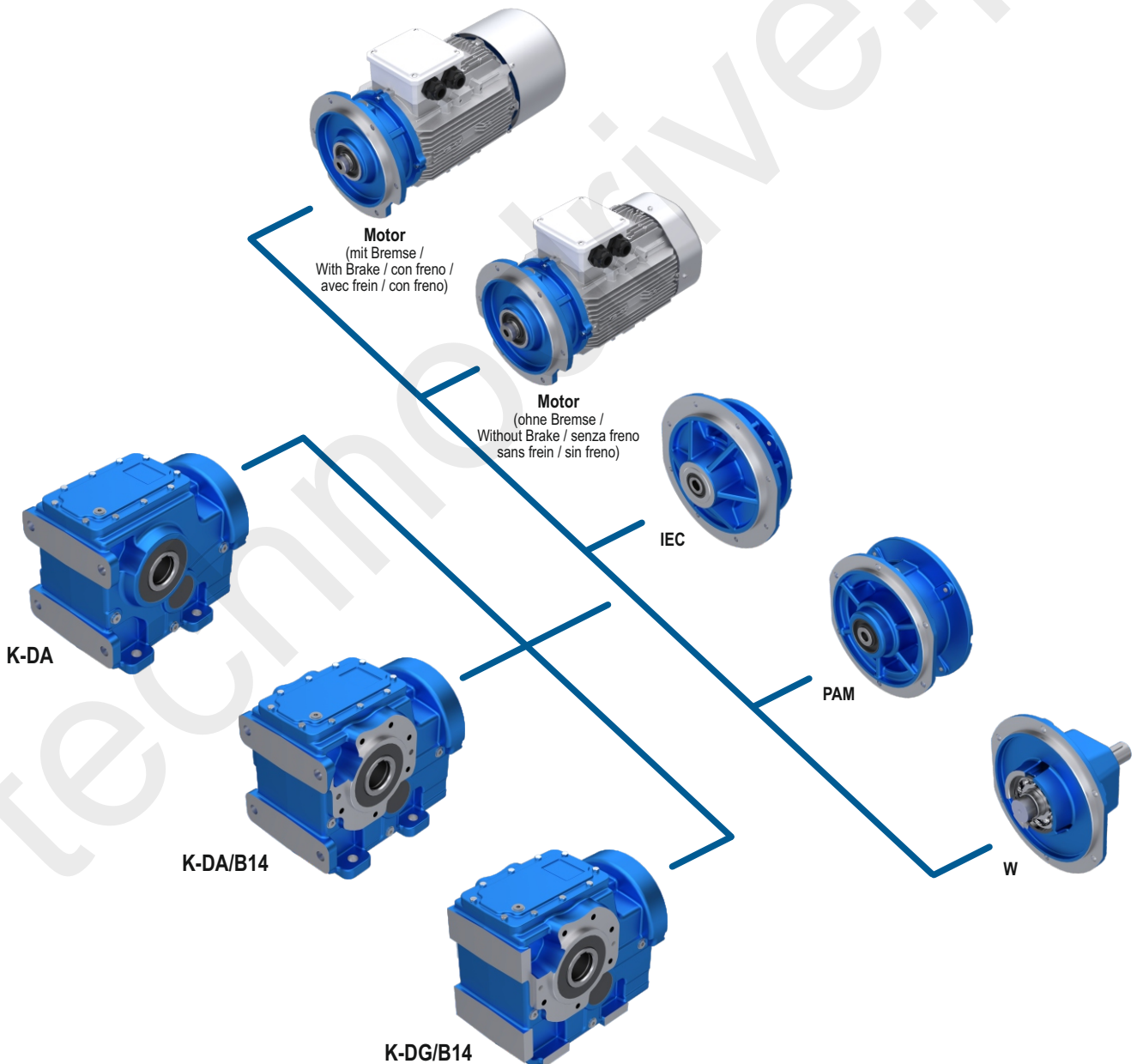

DE PRODUKTE
FR PRODUITS

EN PRODUCTS
ES PRODUCTOS

IT PRODOTTI

35390 - 40390 - 50390 - 60390

K ... DA

Fußbefestigung / Hohlwelle. - Foot mounting / hollow shaft. -
Fissaggio piede / albero cavo. - Fixation à pattes / arbre creux. -
Fijación por patas / eje hueco.

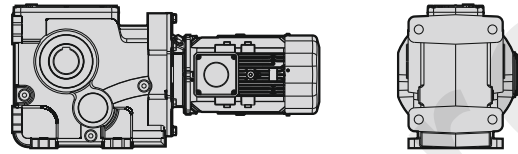

K ... DA-KS

Fußbefestigung / Schrumpfscheibe. - Foot mounting / shrink disc shaft. -
Fissaggio piede / albero calettatore. - Fixation à pattes / arbre avec frette -
Fijación por patas / eje hueco con aro de apriete

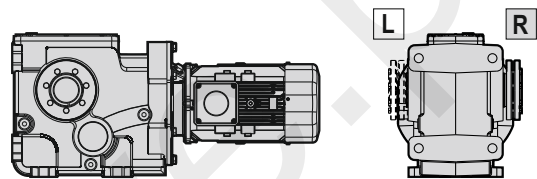

K ... TMA

Fußbefestigung / Vollwelle. - Foot mounting / solid shaft. -
Fissaggio piede / albero pieno - Fixation à pattes / arbre en -
Fijación por patas / eje macizo

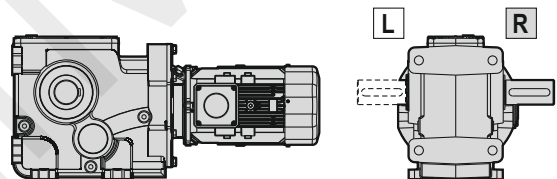

K ... ÇMA

Fußbefestigung / doppelte Abtriebswelle -
Foot mounting / double output shaft. - Fissaggio piede / albero doppio.
Fixation à pattes / arbre double. - Fijación por patas / eje doble.

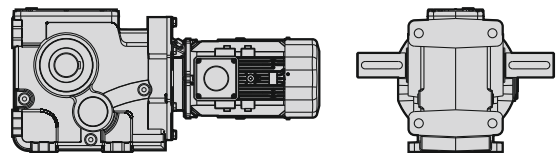

DE PRODUKTE
FR PRODUITS

EN PRODUCTS
ES PRODUCTOS

IT PRODOTTI

35390 - 40390 - 50390 - 60390

K ... DG - B14

Flanschbefestigung / Hohlwelle. - Flange mounting / hollow shaft. -
Fissaggio flangia / albero cavo. - Fixation à bride / arbre creux. -
Fijación por brida / eje hueco.

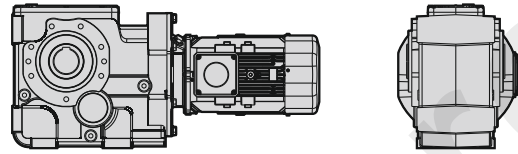

K ... DG - KS - B14

Flanschbefestigung / Schrumpfscheibe. -
Flange mounting / shrink disc shaft. - Fissaggio flangia / albero calettatore.
Fixation à bride / arbre avec frette
Fijación por brida / eje hueco con aro de apriete

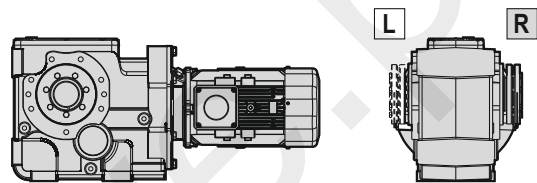

K ... TMG - B14

Flanschbefestigung / Vollwelle - Flange mounting / solid shaft -
Fissaggio flangia / albero pieno - Fixation à bride / arbre en -
Fijación por brida / eje macizo

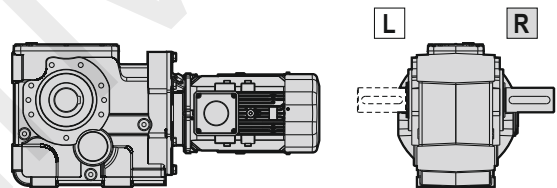

K ... ÇMG - B14

Flanschbefestigung / doppelte Abtriebswelle.
Flange mounting / double output shaft. - Fissaggio flangia / albero doppio.
Fixation à bride / arbre double. - Fijación por brida / eje doble.

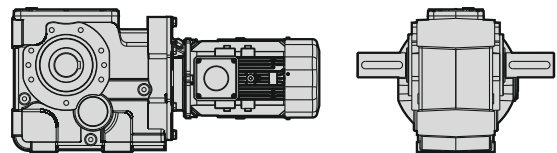

K ... DG - TK

Flanschbefestigung / Drehmomentstütze - Flange mounting / torque arm
Fissaggio flangia / Braccio di reazione - Fixation à bride / Bras de réaction
Fijación por brida / Brazo de reacción

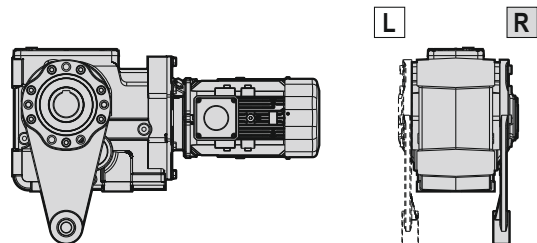

K ... DG - B5

Flanschbefestigung / Hohlwelle. - Flange mounting / hollow shaft.
Fissaggio flangia / albero cavo. - Fixation à bride / arbre creux.
Fijación por brida / eje hueco.

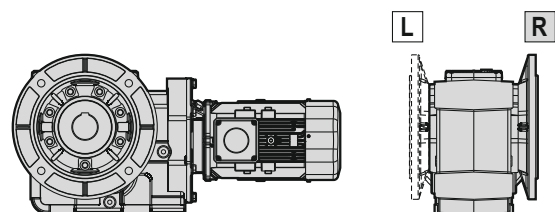

Falls nicht anders vereinbart, wird das Getriebe mit Flansch in Position R, auf die M1- Einbaulage bezogen, geliefert. / Unless specified otherwise, the reduction unit is supplied with the flange in pos. R referred to position M1. / Se non diversamente specificato il riduttore viene fornito con flangia in pos. R riferito alla posizione di piazzamento M1. / Si non différemment spécifié, le réducteur est livré avec bride en pos. R correspondant à la position de montage M1. / Si no diversamente especificado, el reductor se entrega con brida en pos. R, relacionado a la posición de montaje M1.

DE PRODUKTE
FR PRODUITS

EN PRODUCTS
ES PRODUCTOS

IT PRODOTTI

35390 - 40390 - 50390 - 60390 - 70390 - 90390 - 100390

K ... DA - B14

Flanschbefestigung / Hohlwelle. - Flange mounting / hollow shaft. -
Fissaggio flangia / albero cavo. - Fixation à bride / arbre creux. -
Fijación por brida / eje hueco.

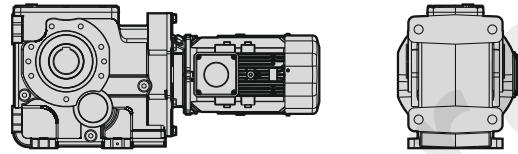

K ... DA-KS - B14

Fuß-Flanschbefestigung / Schrumpfscheibe.
Foot-Flange mounting / shrink disc shaft.
Fissaggio piede - flangia / albero calettatore.
Fixation à pattes bride / arbre avec frette
Fijación patas brida / eje hueco con aro de apriete

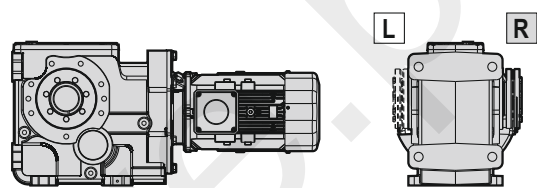

K ... TMA - B14

Fuß-Flanschbefestigung / Vollwelle - Foot-flange mounting / solid shaft
Fissaggio piede-flangia / albero pieno - Fixation à pattes et bride / arbre en
Fijación patas-brida / eje macizo

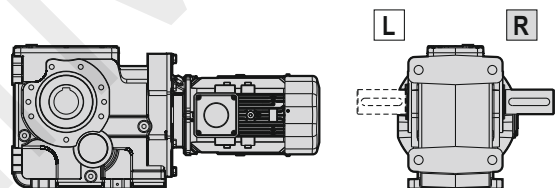

K ... ÇMA - B14

Fuß-Flanschbefestigung / doppelte Abtriebswelle -
Foot-flange mounting / double output shaft.
Fissaggio piede-flangia / albero doppio. -
Fixation à pattes bride / arbre double. - Fijación patas-brida / eje doble.

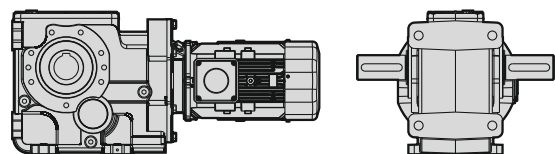

K ... DA - TKP - B14

Fuß-Flanschbefestigung / Drehmomentkonsole -
Foot-flange mounting / Torque console
Fissaggio piede-flangia / Braccio di reazione -
Fixation à pattes bride / Bras de réaction
Fijación patas-brida / Brazo de reacción

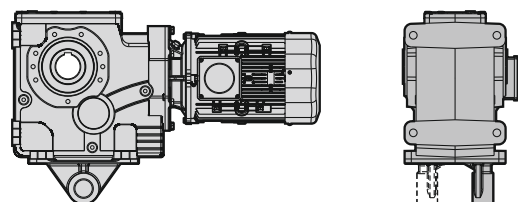

DE FORMULAR FÜR GETRIEBEAUSWAHL

1- GETRIEBE

Sektor :

Anwendungsbereich:.....

Betriebsstunden/Tag:

<4 [] 4-8 [] 8-16 [] >16 []

Anlauf pro Stunde:

0-50 [] 50-100 [] 100-200 [] 200-300 []
300-500 [] 500-700 [] 700-1000 [] >1000 []

Antriebsoption: mit Motor [] ohne Motor []

Geforderte Motorleistung:.....kW

Angeforderte Motordrehzahl:.....min⁻¹

Angeforderter Abtriebsdrehzahl:.....min⁻¹

2 - ANTRIEB - ABTRIEB

Antriebstyp:

Wechselstrommotor [] Wechselstrommotor + Wechselrichter [] Servomotor []
Hydromotor [] Freie Antriebswelle [] Sonstiges []

Motoranschlussflansch (bei Elektromotor):

Gekoppelt [] IEC B5 [] PAM B5 []
PAM B14 [] NEMA []

Antriebswelleneigenschaft (bei freier Antriebswelle):

mit Passfeder [] Sonstiges.....

Antriebsart der Antriebswelle (bei freier Antriebswelle):

Elastische Kupplung [] Hydraulische Kupplung [] Kettenrad bei kleinen Drehzahlen []
Stirnrad [] Zahnriemen [] Keilriemen [] Spannrollenriemen []

Belastungsart der Antriebswelle (bei freier Antriebswelle):

Radiale BelastungN
Axiale Belastung.....N / Zug [] Druck []

Abtriebswelleneigenschaft (bei freier Antriebswelle):

Vollwelle [] Hohlwelle [] Welle mit Schrumpfscheibe []
Sonstiges.....

Antriebsart der Abtriebswelle:

Direkt [] Elastische Kupplung [] Hydraulische Kupplung [] Stirnrad [] Keilriemen []
Kettenrad bei kleinen Drehzahlen [] Zahnriemen [] Spannrollenriemen []

Belastungsart der Abtriebswelle:

Radiale BelastungN
Axiale Belastung.....N / Zug [] Druck []

3 - MONTAGE

Einbaulage:

M1 [] M2 [] M3 [] M4 [] M5 [] M6 []

Rücklaufsperre:

Ja [] Nein []

Höhe über dem Meeresspiegel:

0-1000 [] 1000-2000 [] 2000-3000 [] 3000-4000 [] 4000-5000 []

Umgebungsbedingungen:

Ein (1,25 m/sn) [] Aus (4 m/sn) []

Umweltbedingungen:

Normal [] staubig [] feucht [] trocken []

Sonstiges.....

Umgebungstemperatur:.....°C

4 - MOTOR

Elektrischer Wert:

Stromspannung.....V

Frequenz.....Hz

Schutzklasse:

IP55 [] IP65 [] Ex-geschützt []

Andere IP.....

Ausrichtung des Klemmenkastens:

1 [] 2 [] 3 [] 4 []

Thermistor:

Ja [] Nein []

Bremse:

Ja [] Nein []

Atex:

2G [] 2D [] Nein []

Sonstiges.....

Andere Notizen:

.....
.....
.....
.....
.....
.....
.....
.....

Bitte geben Sie die notwendigen Informationen an, um das richtige Getriebe auswählen zu können!

EN GEARBOX SELECTION FORM

1- GEAR UNIT

Sector for which will be used:

Application area:

Daily working hour:
 <4 [] 4-8 [] 8-16 [] >16 []

Revolution per hours:
 0-50 [] 50-100 [] 100-200 [] 200-300 []
 300-500 [] 500-700 [] 700-1000 [] >1000 []

Input option: With motor [] Without motor []

Requested Motor Power:kW

Requested Motor Rotation:min⁻¹

Requested Output Rotation:min⁻¹

2 - INPUT - OUTPUT

Drive type:
 AC Motor [] AC Motor + Invertor [] Servo Motor []
 Hydromotor [] Free Input Shaft [] Diđer []

Motor Connection Flange (With Electric Motor):
 Direct [] IEC B5 [] PAM B5 []
 PAM B14 [] NEMA []

Property of Input Shaft (with free input shaft):
 With Key [] Other.....

Driving type of Input Shaft(with free input shaft):
 Elastic Coupling [] Hydraulic Coupling [] For Chain Drive With Low Speed []
 For Spur Gear [] For Trigger Belt [] For V belt [] Flat Belt With Spanning Pulley []

Input Shaft Load case (with free input shaft):
 Radial Load.....N
 Axial Load.....N / Draw [] Impression []

Property of Output Shaft (with free input shaft):
 Solid Shaft [] Hollow shaft [] Shaft for Shrink Disc []
 Other.....

Output Shaft Drive type:
 Direct [] Elastic Coupling [] Hydraulic Coupling [] Chain Drive With Low Speed []
 Spur Gear [] Trigger Belt [] V Belt [] Flat Belt With Spanning Pulley []

Output Shaft Load case:
 Radial Load.....N
 Axial Load.....N / Draw [] Impression []

3 - MOUNTING

Mounting Position:
 M1 [] M2 [] M3 [] M4 [] M5 [] M6 []

Backstop Situation:
 Yes [] No []

Altitude above sea level:
 0-1000 [] 1000-2000 [] 2000-3000 [] 3000-4000 [] 4000-5000 []

Ambient Situation:
 Open (1,25 m/sn) [] Close (4 m/sn) []

Ambient Conditions:
 Normal [] Dusty [] Humid [] Dry []
 Other.....

Ambient Temperature :°C

4 - MOTOR

Elektrical Value:
 Voltage.....V
 Frequency.....Hz

Protection Class :
 IP55 [] IP65 [] Exproof []
 Other IP.....

Terminal Box Position:
 1 [] 2 [] 3 [] 4 []

Thermistor :
 Yes [] No []

Brake Situation:
 Yes [] No []

Atex:
 2G [] 2D [] Yok []
 Other.....

Other Notes:

Please give required informations for selecting correct reducer!

IT MODULO DI SELEZIONE RIDUTTORE

1- RIDUTTORE

Settore per il quale verrà utilizzato:

Area di applicazione:.....

orario di lavoro giornaliero:

<4 [] 4-8 [] 8-16 [] >16 []

Rivoluzione all'ora:

0-50 [] 50-100 [] 100-200 [] 200-300 []
300-500 [] 500-700 [] 700-1000 [] >1000 []

Opzione di input: con motore [] Senza motore []

Potenza motore richiesta:.....kW

Rotazione motore richiesta:.....min⁻¹

Rotazione uscita richiesta:.....min⁻¹

2 - INGRESSO-USCITA

Tipo di guida:

AC Motore [] AC Motore + invertitore [] Servomotore []
Idromotore [] Albero di ingresso libero [] Altro []

Flangia di collegamento del motore (con motore elettrico):

Diretto [] IEC B5 [] PAM B5 []
PAM B14 [] NEMA []

Proprietà dell'albero di ingresso (con albero di ingresso libero):

Con Chiave [] Altro.....

Tipo di guida dell'albero di ingresso (con albero di ingresso libero):

Accoppiamento elastico [] Accoppiamento idraulico []
Per trasmissione a catena a bassa velocità [] Per ingranaggio cilindrico []
Per cinghia a scatto [] Per cinghia trapezoidale [] Cinghia piatta con puleggia []

Caso di carico dell'albero di ingresso (con albero di ingresso libero):

Carico radiale.....N
Carico assiale.....N / Disegno [] Impressione []

Proprietà dell'albero di uscita (con albero di ingresso libero):

Albero solido [] Albero cavo [] Albero per calettatore []
Altro.....

Tipo di trasmissione dell'albero di uscita:

Diretto [] Accoppiamento elastico [] Accoppiamento idraulico []
Per trasmissione a catena a bassa velocità [] Per ingranaggio cilindrico []
Per cinghia a scatto [] Per cinghia trapezoidale [] Cinghia piatta con puleggia []

Caso di carico dell'albero di uscita:

Carico radiale.....N
Carico assiale.....N / Disegno [] Impressione []

3 - MONTAGGIO

Posizione di montaggio:

M1 [] M2 [] M3 [] M4 [] M5 [] M6 []

Stato di blocco:

C'è [] No []

Altitudine sul livello del mare:

0-1000 [] 1000-2000 [] 2000-3000 [] 3000-4000 [] 4000-5000 []

Situazione ambientale:

Aperto (1,25 m/sn) [] Chiusa(4 m/sn) []

Condizioni ambientali:

Normale [] Polverosa [] Umido [] Asciutto []

Altro.....

Temperatura ambiente:.....°C

4 - MOTORE

Valore elettrico:

Voltaggio.....V
Frequenza.....Hz

Classe di protezione:

IP55 [] IP65 [] Exproof []
Altro IP.....

Posizione della morsetteria:

1 [] 2 [] 3 [] 4 []

Termistore :

Si [] No []

Situazione del freno:

Si [] No []

Atex:

2G [] 2D [] Yok []

Altro.....

Altre note:

.....
.....
.....
.....
.....
.....
.....
.....

Si prega di fornire le informazioni necessarie per selezionare il riduttore corretto!

FR FORMULAIRE DE SÉLECTION DE RÉDUCTEURS

1- RÉDUCTEUR

Secteur pour lequel sera utilisé:

Domaine d'application:

heures de travail quotidiennes:

<4 [] 4-8 [] 8-16 [] >16 []

Révolution par heure:

0-50 [] 50-100 [] 100-200 [] 200-300 []
300-500 [] 500-700 [] 700-1000 [] >1000 []

Options d'entrée: Avec moteur [] Sans moteur []

Puissance moteur demandée:kW

Régime moteur demandé:min⁻¹

Rotation de sortie demandée:min⁻¹

2 - ENTRÉE-SORTIE

Type de lecteur:

AC Moteur [] AC Moteur + onduleur [] Servomoteur []
Hydromoteur [] Arbre d'entrée libre [] Autre []

Bride de connexion du moteur (avec moteur électrique):

Direct [] IEC B5 [] PAM B5 []
PAM B14 [] NEMA []

Propriété de l'arbre d'entrée (avec arbre d'entrée libre):

Avec clé [] Autre:

Type d'entraînement de l'arbre d'entrée (avec arbre d'entrée libre):

Accouplement élastique [] Accouplement hydraulique [] Pour entraînement par chaîne à basse vitesse [] Pour engrenage droit [] Pour ceinture de déclenchement []
Pour courroie trapézoïdale [] Courroie plate avec poulie couvrante []

Cas de charge de l'arbre d'entrée (avec arbre d'entrée libre):

Charge radiale.....N
Charge axiale.....N / dessiner [] Impression []

Propriété de l'arbre de sortie (avec arbre d'entrée libre):

Arbre plein [] Creux arbre [] Arbre pour disque rétractable []
Autre:

Type d'entraînement de l'arbre de sortie:

Direct [] Accouplement élastique [] Accouplement hydraulique [] Pour entraînement par chaîne à basse vitesse [] Pour engrenage droit [] Pour ceinture de déclenchement []
Pour courroie trapézoïdale [] Courroie plate avec poulie couvrante []

Cas de charge de l'arbre de sortie:

Charge radiale.....N
Charge axiale.....N / dessiner [] Impression []

3 - MONTAGE

Position de montage:

M1 [] M2 [] M3 [] M4 [] M5 [] M6 []

Statut de verrouillage:

Oui [] Non []

Altitude au-dessus du niveau de la mer:

0-1000 [] 1000-2000 [] 2000-3000 [] 3000-4000 [] 4000-5000 []

Situation ambiante:

Ouvert (1,25 m/sn) [] Ferme (4 m/sn) []

Conditions ambiantes:

Normal [] Poussiéreux [] Humide [] Sec []

Autre:

Température ambiante:°C

4 - MOTEUR

Valeur électrique:

Voltage.....V
Fréquence.....Hz

Classe de protection:

IP55 [] IP65 [] Exproof []
Autre IP:

Emplacement de la boîte à bornes:

1 [] 2 [] 3 [] 4 []

Thermistance :

Oui [] Non []

Situation de freinage:

Oui [] Non []

Atex:

2G [] 2D [] Yok []

Autre:

Autres notes:

.....
.....
.....
.....
.....
.....
.....
.....

Veuillez fournir les informations requises pour sélectionner le bon réducteur!

ES FORMULARIO DE SELECCIÓN DEL REDUCTOR

1- REDUCTOR

Sector para el que se utilizará:

Área de aplicación:

Horas de trabajo diarias:

<4 [] 4-8 [] 8-16 [] >16 []

Revolución por hora:

0-50 [] 50-100 [] 100-200 [] 200-300 []
300-500 [] 500-700 [] 700-1000 [] >1000 []

Opción de entrada: Con motor [] Sin motor []

Potencia del motor solicitada:kW

Rotación de motor solicitada:min⁻¹

Retorno de salida deseado:min⁻¹

2 - ENTRADA-SALIDA

Tipo de unidad:

AC Motor [] AC Motor + Inversor [] Servo Motor []
Hydromotor [] Eje de entrada libre [] Otro []

Brida de conexión del motor (con motor eléctrico):

Direct [] IEC B5 [] PAM B5 []
PAM B14 [] NEMA []

Propiedad del eje de entrada (con eje de entrada libre):

Con llave [] Otro.....

Tipo de conducción del eje de entrada (con eje de entrada libre):

Acoplamiento elástico [] Acoplamiento hidráulico [] Para transmisión por cadena
con baja velocidad [] Para engranaje recto [] Para cinturón de gatillo []
Para correa trapezoidal [] Correa plana con polea extensible []

Eje de entrada Caso de carga (con eje de entrada libre):

Carga Radial.....N
Carga axial.....N / Dibujar [] Impresión []

Propiedad del eje de salida (con eje de entrada libre):

Eje sólido [] eje hueco [] Eje para disco retráctil []
Otro.....

Tipo de transmisión del eje de salida:

Directo [] Acoplamiento elástico [] Acoplamiento hidráulico [] Para transmisión por
cadena con baja velocidad [] Para engranaje recto [] Para cinturón de gatillo []
Para correa trapezoidal [] Correa plan con polea extensible []

Caso de carga del eje de salida:

Carga Radial.....N
Carga axial.....N / Dibujar [] Impresión []

3 - MONTAJE

Posición de montaje:

M1 [] M2 [] M3 [] M4 [] M5 [] M6 []

Situación de respaldo:

Sí [] No []

Altitud sobre el nivel del mar:

0-1000 [] 1000-2000 [] 2000-3000 [] 3000-4000 [] 4000-5000 []

Situación ambiental:

abierto (1,25 m/sn) [] Cerca (4 m/sn) []

Condiciones ambientales:

Normal [] Polvoriento [] Húmedo [] Seco []

Otro.....

Temperatura ambiente:°C

4 - MOTOR

Valor eléctrico:

Voltaje.....V
Frecuencia.....Hz

Clase de protección:

IP55 [] IP65 [] Exproof []
Other IP.....

Posición de la caja de terminales:

1 [] 2 [] 3 [] 4 []

Termistor:

Sí [] No []

Situación del freno:

Sí [] No []

Atex:

2G [] 2D [] Yok []

Otro.....

Otras notas:

.....
.....
.....
.....
.....
.....
.....

Proporcionar la información necesaria para elegir el reductor adecuado!

DE BEISPIEL BESTELLBESCHREIBUNG
FR EXEMPLE DE COMMANDE

EN EXAMPLE FOR ORDERING
ES EJEMPLO ORDEN DE COMPRA

IT ESEMPIO DI ORDINAZIONE

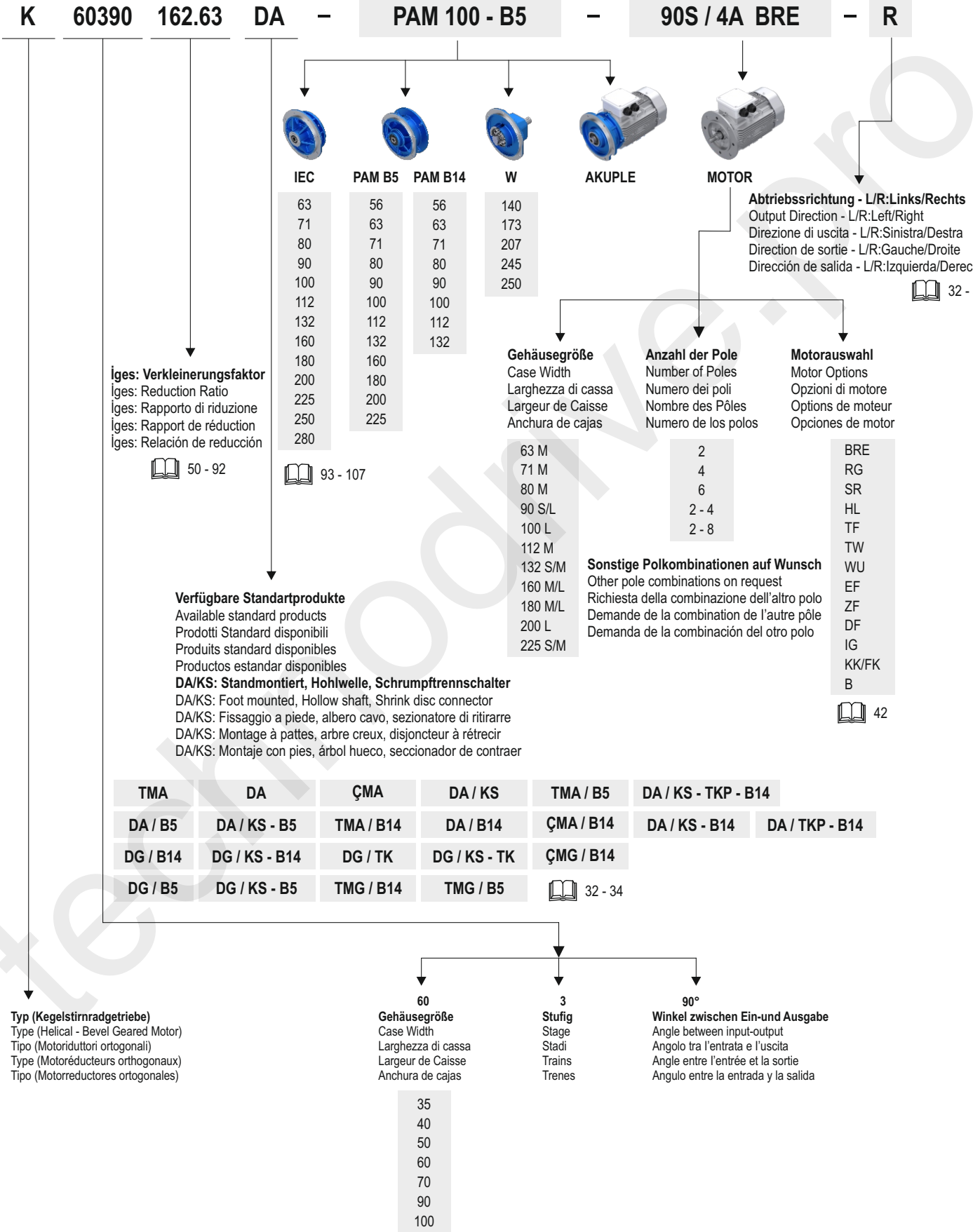

DE	BEZEICHNUNG	EN	DESIGNATION	IT	DESIGNAZIONE
FR	DÉSIGNATION	ES	DESIGNACIÓN		

K	Kegelstirnradtriebmotoren und Kegelstirnradgetriebe Helical bevel geared motors and gear units Motoriduttori e riduttori ortogonali a coppia conica Motoréducteurs et réducteurs à axes orthogonaux Motorreductores y reductores de ejes ortogonales				
40390	Baugröße 40 - 3 Übersetzungsstufen - Ausführung in Grauguss Size 40, 3 reduction stages, cast iron series Grandezza 40, 3 stadi di riduzione, serie in ghisa Grandeur 40, 3 trains d'engrenages, série en fonte Tamaño 40, 3 trenes de engranajes, gama de fundición				
FA - FB - FC	Abtriebsflansch Output flange Flangia di uscita Bride de sortie Brida de salida				
42.28	Übersetzungsverhältnis Reduction ratio Rapporto di riduzione Rapport de réduction Relación de reducción				
M1	Einbaulage Mounting position Posizione di piazzamento Position de montage Posición de montaje				
Abmessungen antriebsseitig / Input dimensions / Dimensioni di entrata / Dimensions d'entrée / Dimensiones de entrada					
PAM	Für Motoranbau vorbereitet Fitted for motor coupling Predisposto per attacco motore Prédisposé pour montage moteur standard Predisuesto para montaje motor				
250	Motorflansch - Durchmesser Motor flange diameter Diametro flangia motore Diamètre bride moteur Diámetro brida motor	28	Motorwellen - Durchmesser Drive - shaft diameter Diametro albero motore Diamètre arbre moteur Diámetro eje motor		
Abmessungen abtriebsseitig / Output dimensions / Dimensioni di uscita / Dimensions de sortie / Dimensiones de salida					
300	Durchmesser Abtriebsflansch Output flange diameter Diametro flangia uscita Diamètre de la bride de sortie Diámetro brida de salida	40	Durchmesser Abtriebswelle Output shaft diameter Diametro albero uscita Diamètre de l'arbre de sortie Diámetro eje de salida		

DE	NOMENKLATUR	EN	NOMENCLATURE	IT	NOMENCLATURA
FR	NOMENCLATURE	ES	NOMENCLATURA		

<p>Eingabeoptionen Input Options opzioni di ingresso options d'entrée opciones de entrada</p>	<p>W = Ausführungen mit Antriebsvollwelle / Input shaft versions / Versioni con albero maschio in ingresso / Version avec arbre en entrée / Versión con eje macho de entrada</p> <p>IEC = Die Verbindung Motor Getriebe erfolgt über Kupplung / Fitted for motor mounting with flexible coupling / Predisposto per attacco motore con giunto / Prêdisposé pour montage moteur avec joint / Predisposto para montaje motor con acoplamiento</p> <p>T = Turbokupplung / Turbo coupling / Turbogiunto / Coupleur hydraulique / Turboacoplador</p>
<p>Motor Motor Motore Moteur Motor</p>	<p>Drehstrommotor Motorgröße 63 - 280 / Three phase motor Motor size 63 - 280 / Motori trifase, Grandezze 63 - 280 / Motore thriphasé, taille moteur 63 - 280 / Motores trifásicos, Tamaño de carcasas 63 - 280</p>
<p>Anzahl der Pole Number of Poles Numero dei poli Nombre des Pôles Numero de los polos</p>	<p>2 = 2 Pole / 2 Poles / 2 Poli / 2 Pôles / 2 Polos</p> <p>4 = 4 Pole / 4 Poles / 4 Poli / 4 Pôles / 4 Polos</p> <p>6 = 6 Pole / 6 Poles / 6 Poli / 6 Pôles / 6 Polos</p> <p>Sonstige Polkombinationen auf Wunsch / Other pole combinations on request / Richiesta della combinazione dell'altro polo / Demande de la combination de l'autre pôle / Demanda de la combinación del otro polo</p>
<p>Motorauswahl Motor Options Opzioni di motore Options de moteur Opciones de motor</p>	<p>BRE = mit Bremsen / With brake / Freno / avec frein / Freno</p> <p>EF = Separate Lüfter, Einphasig / Separate fan, single phase / Ventilatore separato, monofase / Ventilateur séparé, une phase / Ventilador por separado de una sola fase</p> <p>ZF = Separate Lüfter, Zweiphasig / Separate fan, double phase / Ventilatore separato, doppia fase / Ventilateur séparé, double-phase / Ventilador por separado, de doble fase</p> <p>DF = Separate Lüfter, Drei-Phasen / Separate fan, three phase / Ventilatore separato, trifase / Ventilateur séparé, trois phases / Ventilador por separado, tres de fase</p> <p>IG = mit Encoder / With encoder / Con encoder / avec codeur / con codificador</p> <p>KK/FK = Kupplungs / With clutches / Con frizioni / embrayage / embrague</p> <p>SR = Staubsichere Bremse / Brake dust - proof / Freno a prova di polvere / Frein à l'épreuve de la poussière / De frenos a prueba de polvo</p> <p>TF = Thermistor / Thermistor / Termistore / Thermistance / Termistor</p> <p>RG = Bremse auf Korrosion geschützt / Brake corrosion - protected / Freno resistente alla corrosione / Frein à la corrosion protégées / Freno protegida contra la corrosión</p> <p>WU = Sanftanlauf - Rotor / Soft start rotor / Soft start rotore / Démarrage en douceur du rotor / Soft desde el rotor</p> <p>B = Rücklaufsperr / Backstop / Bloccato contro il ritorno / Verrouillé contre le retour / Bloqueado en contra de devolución</p> <p>TW = Temperatursicherung / Thermal trip / Un sensibile al calore / A sensible à la chaleur / Un sensible al calor</p> <p>HL = Handbremsmotoren / Brake motor with hand release / Motore autofrenante mano / Moteur de frein à main / motores freno manuales</p>

DE ZUBEHÖR
FR ACCESSOIRES

EN ACCESSORIES
ES ACCESORIOS

IT ACCESSORI

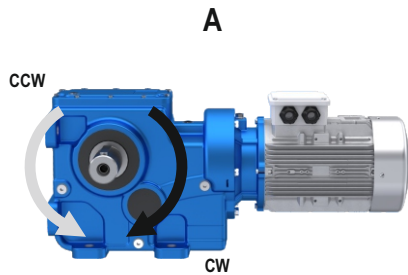

Ausgangseite / Output side /
Lato uscita / Côté sortie / Lado de salida

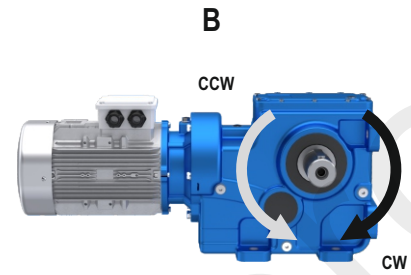

Ausgangseite / Output side /
Lato uscita / Côté sortie / Lado de salida

Rücklaufsperre

Das Getriebe ist mit Rücklaufsperre auf der Antriebswelle erhältlich. Die Rücklaufsperre verhindert die Rotation in die falsche Drehrichtung. Entsprechend der Größe ist sie im Antriebsflansch oder dem Motor integriert. Wichtig ist die Angabe der gewünschten Abtriebsdrehrichtung.

Backstop device

The gear reducer can be supplied with backstop device on input shaft. Backstop device allows output shaft rotation in only one sense of direction; according to the size, it is available in the input flange or in the motor with the same dimensions. It is important to specify the required sense of direction on the order.

Dispositivo antiretro

Il riduttore può essere fornito munito di dispositivo antiretro sull'asse veloce. L'antiretro permette la rotazione degli alberi in un solo senso, a seconda della grandezza è disponibile nella flangia PAM oppure nel motore, senza ingombri aggiuntivi. È molto importante, in fase di ordine, specificare il senso di rotazione richiesto.

Système antidéviureur

Le réducteur de vitesse peut être fourni avec le dispositif antiretour sur l'axe d'entrée. Le dispositif anti retour permet la rotation des arbres de sortie dans un seul sens; selon la taille, il est disponible dans la bride d'entrée ou dans le moteur avec les mêmes dimensions. Il est important de spécifier le sens de la direction demandé sur l'ordre.

Dispositivo antirretorno

El reductor puede suministrarse con un dispositivo antirretorno en el eje veloz. El antirretorno permite la rotación de los ejes en un solo sentido, según el tamaño está disponible en la brida PAM o en el motor, sin incremento de dimensiones. Es muy importante especificar en el pedido el sentido de rotación requerido.

Motor	063	071	080	090	100 - 112	132	160	180	200	225	250	280
Größe / Size Grandezza Taille Tamaño	140x11	160x14	200x19	200x24	250x28	300x38	350x42	350x48	400x55	450x60	550x65	550x75
35390	B5/B14	B5/B14	B5/B14	B5/B14	B5/B14							
40390			B5/B14	B5/B14	B5/B14	B5/B14						
50390			B5/B14	B5/B14	B5/B14	B5/B14	B5					
60390				B5/B14	B5/B14	B5/B14	B5	B5				
70390					B5/B14	B5/B14	B5	B5	B5			
90390						B5/B14	B5	B5	B5	B5		
100390							B5	B5	B5	B5	B5	B5

Drehsinn

Die Kegelradgetriebe werden mit Drehrichtung gemäß folgendem Schema serienmäßig geliefert. Auf Anfrage kann die Drehrichtung umgekehrt werden; in diesem Fall ist bei Auftragserteilung "umgekehrte Drehrichtung" anzugeben.

Direction of rotation

Helical bevel reduction units are supplied as "standard" with rotation as shown in the below diagram. On request the direction of rotation can be reversed; in this case it is necessary to specify "opposite rotation to catalogue" when ordering.

Senso di rotazione

I riduttori ortogonali vengono forniti "di serie" con rotazione come da schema sotto riportato. A richiesta il senso di rotazione può essere invertito, in questo caso occorre specificare in fase di ordine: rotazione opposta a catalogo.

Sens de rotation

Les réducteurs orthogonaux sont livrés "de série" avec rotation comme d'après le schéma. Sur demande, le sens de rotation peut être inversé; dans ce cas, il faut spécifier lors de la commande: rotation inversée par rapport à celle du catalogue.

Sentido de rotación

Los reductores ortogonales son entregados "de serie" con rotación según el esquema abajo mencionado. Bajo pedido el sentido de rotación puede ser invertido; en este caso, es necesario detallar en caso de pedido: rotación contraria a la indicada en el catálogo.

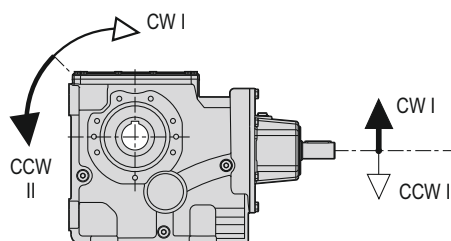

DE ZUBEHÖR
FR ACCESSOIRES

EN ACCESSORIES
ES ACCESORIOS

IT ACCESSORI

Abtriebswellen / Low speed shafts / Alberi lenti / Arbres pv / Ejes lentos

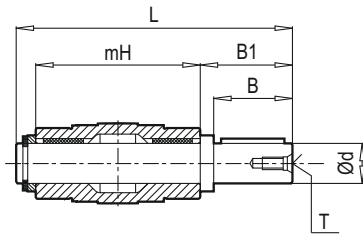

TMA - TMG

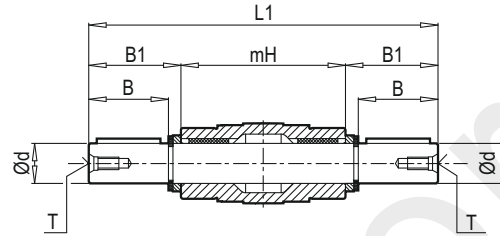
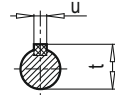

ÇMA - ÇMG

	Ød h6	B	B1	mH	L	L1	T	u	t
K35390	35	58	62	140	210.5	264	M12	10	38
K40390	40	80	84.25	180	273	348.5	M16	12	43
K50390	50	100	105	210	325	420	M16	14	53.5
K60390	60	120	125	240	375	490	M20	18	64
K70390	70	140	146	300	458	592	M20	20	74.5
K90390	90	170	176.5	350	540	703	M20	25	95
K100390	100	210	217.5	445	677	880	M20	28	106

Wellenabdeckung / Protection cover / Coperchio di protezione / Couvercle de protection / Tapa de protección (KK)

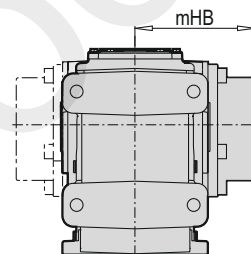

KS / KK	mHB
K35390	118
K40390	135
K50390	150
K60390	175
K70390	218
K90390	257
K100390	302

KK	mHB
K35390	101
K40390	118
K50390	135
K60390	157
K70390	193
K90390	217
K100390	267

DE ZUBEHÖR

EN ACCESSORIES

IT ACCESSORI

FR ACCESSOIRES

ES ACCESORIOS

Schrumpfscheibe / Shrink disc / Calettatore / Frette d'accouplement / Aro de apriete

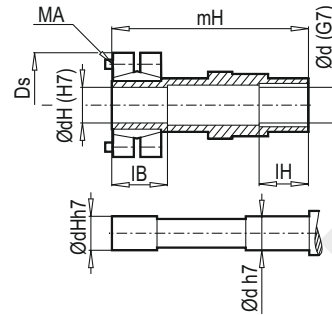
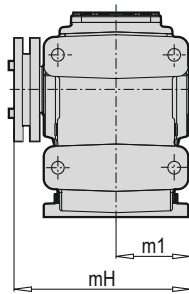

	$\text{Ø}dH$	$\text{Ø}d$	mH	$m1$	IH	IB	Ds	MA 12.9 (Nm)
K35390	35	36	173	70	40	35	80	15
K40390	40	41	217	90	50	40	100	15
K50390	50	51	248	105	55	40	115	15
K60390	60	61	282	120	60	50	145	40
K70390	70	72	356	150	70	65	170	50
K90390	90	92	415	175	80	75	185	70
K100390	100	102	512	222.5	100	100	215	70

DE ZUBEHÖR
FR ACCESSOIRES

EN ACCESSORIES
ES ACCESORIOS

IT ACCESSORI

Drehmomentstütze / Torque arm / Braccio di reazione / Bras de réaction / Brazo de reacción

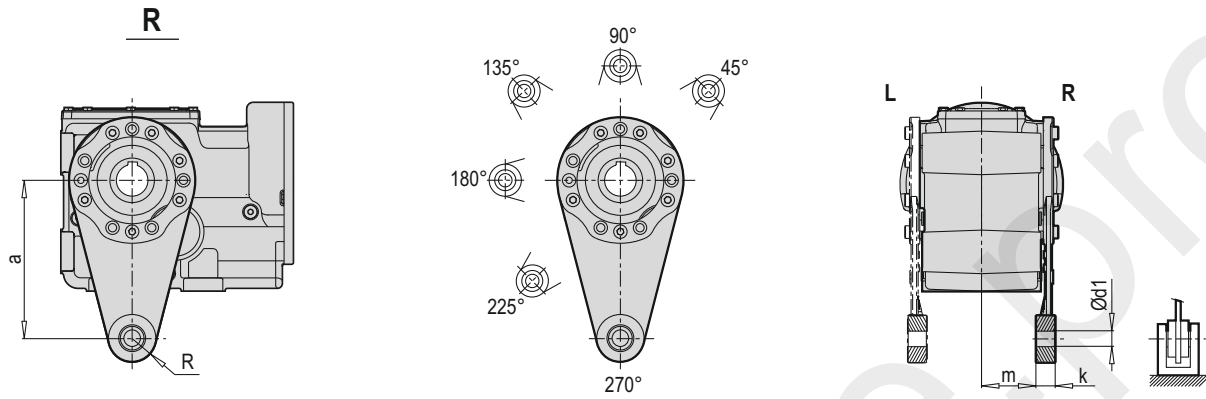

	a	m	Ød1	k	R
35390-F	200	62	20	25	30
40390-F	200	68,5	20	25	30
50390-F	250	83	25	30	35
60390-F	300	91,5	25	40	40
35390-AF	200	62	20	25	30
40390-AF	200	78,5	20	25	30
50390-AF	250	95	25	30	35
60390-AF	300	103,5	25	40	40

Drehmomentkonsole / Torque console / Braccio di reazione / Bras de réaction / Brazo de reacción

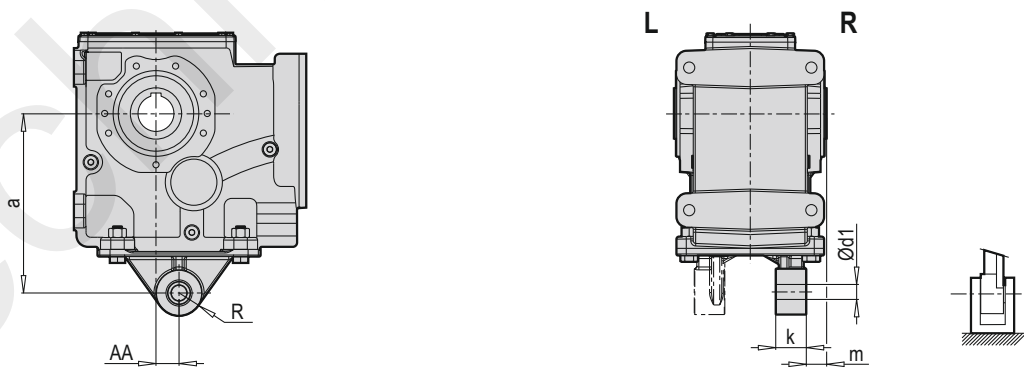

	AA	a	m	Ød1	k	R
K70390	45	350	40	30	60	45
K90390	45	450	45	30	60	45
K100390	60	550	7,5	40	110	65

DE

ZUBEHÖR

EN

ACCESSORIES

IT

ACCESSORI

Aufzuehvorrichtung

Für verschiedene Gehäusegrößen sind optional Abziehvrichtungen für Ausführungen mit Hohlwellenabtrieb erhältlich.

Nutzungsanforderungen für die Abziehvrichtung:

- In der Stirnmitte der Kundenwelle sollte eine Bohrung nach DIN 332/2 vorhanden sein.
- Die Kundenwelle ist mit der Abziehvrichtung kompatibel, mit oder ohne Wellenabsatz.
- Bei Bauform I wird die Kundenwelle mit dem Sicherungsring in der Getriebewelle befestigt. (Teil A)
- Bei Einbaulage II wird die Kundenwelle am Wellenabsatz direkt auf der Getriebewelle befestigt (Teil B)

Puller Kit

The puller kit is optionally available on shaft mounted gear units.

Using conditions:

- The centre hole must be DIN 332/2 for customer solid shaft.
- The customer shaft can be fixed with the puller kit (with shoulder or without shoulder)
- When the assembly in Fig. I is used, the customer shaft is fasten by the circlip in the gear unit shaft. (Track A)
- When the assembly in Fig. II is used, it is fasten directly to the gearbox shaft using the invoice on the customer shaft.

Elementi de fissaggio

Questo è utilizzato per il disegno di ingranaggi montati. Deve essere indicato quando se lo ordina in quanto esistono le esigenze per l'utilizzo.

Condizioni di utilizzo

- La perforazione centrale deve essere adeguatamente macchinata DIN332/2
- L'albero sporgente deve essere montato sia con spallamento dell'albero (II) che senza spallamento dell'albero (I)
- L'albero sporgente senza spallamento dell'albero è montato utilizzando la ghiera di fermo (A)
- L'albero sportenge con spallamento dell'albero è montato utilizzando la ghiera distanziatrice

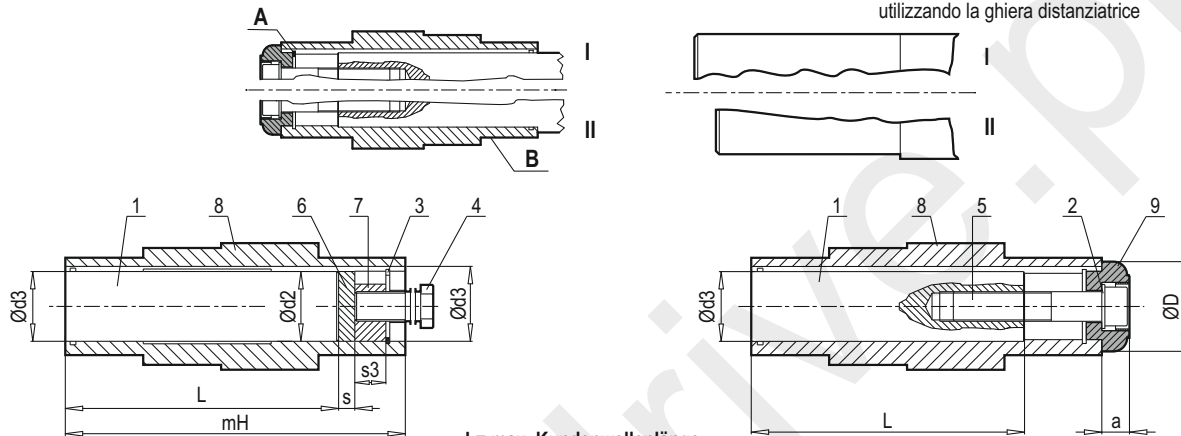

DEMONTAGE / DISASSEMBLY / SMONTAGGIO

L = max. Kundenwellenlänge
L = maximum length of the solid shaft
L = lunghezza massima dell'albero sporgente

MONTAGE / ASSEMBLY / MONTAGGIO

- 1) Kundenwelle
- 2) Federring DIN 127
- 3) * Sicherungsring DIN 127
- 4) * Abziehschraube
- 5) Innensechskantschraube DIN 912
- 6) * Federscheibe
- 7) * Schraubenmutter
- 8) Getriebewelle
- 9) Abziehscheibe

*Wird Nicht von NRW bereitgestellt.

- 1) Customer's shaft
- 2) Washer DIN 127
- 3) * Circlip DIN 472
- 4) * Puller screw
- 5) Socket head screw DIN 912
- 6) * Thrust washer
- 7) * Nut
- 8) Hollow shaft
- 9) Puller washer

*Star signs are shown this item are not provided by NRW

- 1) l'albero del cliente
- 2) Rondella DIN 127
- 3) * Anello di sicurezza DIN 472
- 4) * Vite di alzare
- 5) Vite a testa esagonale DIN 912
- 6) * Rondella reggispinta
- 7) * Dado di alzare
- 8) Albero cavo
- 9) Disco

*Gli articoli segnati con la stella non sono forniti da NRW.

DEMONTAGE:

- 1) Innensechskantschraube muss entfernt werden. (5)
- 2) Die Abziehscheibe muss entfernt werden. (9)
- 3) Federscheibe muss eingelegt sein. (6)
- 4) Die Schraubenmutter muss eingesetzt werden. (7)
- 5) Der Sicherungsring muss montiert sein. (3)
- 6) Die Kundenwelle sollte durch Lösen der Abziehschraube von der Welle getrennt werden. (4)

DISASSEMBLING:

- 1) Loosen the socket head screw. (5)
- 2) Remove puller washer. (9)
- 3) Install spring washer. (6)
- 4) Install nut. (7)
- 5) Install circlip. (3)
- 6) Remove solid shaft from hollow shaft with using puller screw. (4)

SMONTAGGIO:

- 1) Allentare la vite a brugola. (5)
- 2) Rimuovere la rondella dell'estrattore. (9)
- 3) Inserire la rondella elastica. (6)
- 4) Inserire il dado. (7)
- 5) Inserire l'anello elastico. (3)
- 6) Rimuovere l'albero pieno dall'albero cavo utilizzando la vite dell'estrattore. (4)

MONTAGE:

- 1) Die Kundenwelle muss in der Getriebewelle befestigt werden. (8)
- 2) Die Abziehscheibe muss in die Getriebewelle eingelegt werden. (9)
- 3) Die Abziehscheibe und die Sechskantschraube und der Federring müssen miteinander befestigt werden. (9-5-2)

ASSEMBLING:

- 1) The customer shaft must be mounted inside the gear units shaft. (8)
- 2) The puller washer must be mounted inside the gear units shaft. (9)
- 3) The bolt and washer must be fixed with the puller washer. (9-5-2)

MONTAGGIO:

- 1) L'albero del cliente deve essere montato all'interno dell'albero del riduttore. (8)
- 2) La rondella dell'estrattore deve essere montata all'interno dell'albero del riduttore. (9)
- 3) Il bullone e la rondella devono essere fissati con la rondella dell'estrattore. (9-5-2)

Nutzungsbedingungen (für Montage):

- In der Mitte der Kundenwelle muss eine Gewindebohrung nach DIN 332/2 vorhanden sein.
- Die Länge der Kundenwelle darf die Länge "L" nicht überschreiten. Andernfalls können die Abziehelemente nicht verwendet werden. (3-6-7)

Usage Conditions(Assembling):

- The user shaft must be threaded to the center according to DIN 332/2.
- The customer shaft must not exceed the "L" length, otherwise the puller cannot be applied. (pos. 3-6-7)

Condizioni d'uso (montaggio):

- L'albero motore deve essere filettato al centro secondo norma DIN 332/2.
- L'albero del cliente non deve superare la lunghezza "L", altrimenti non è possibile applicare l'estrattore. (pos. 3-6-7)

Nutzungsbedingungen (für Demontage):

- Demontagemasse können anhand von Werksnormen übernommen werden.
- Das Demontageverfahren gilt nur für Vollwellen, deren Abmessung "L" nicht überschreitet.

Usage Conditions(for disassembly):

- Disassembly dimensions can be taken by using factory standards.
- The disassembly procedure is only valid for solid shafts which will be connected to solid shaft and dimension does not exceed "L".

Condizioni d'uso (per lo smontaggio):

- Le dimensioni di smontaggio possono essere prese utilizzando gli standard di fabbrica.
- La procedura di smontaggio è valida solo per alberi pieni che saranno collegati ad alberi pieni con dimensione che non supera "L".

Éléments de fixation

Ceci est utilisé pour le dessin d'engrenages montés II doit être indiqué lorsque l'on commande parce qu'il y a des exigences pour l'utilisation

Conditions d'utilisation

- Le forage central doit être machiné de façon appropriée DIN 332/2
- L'arbre plein doit être monté soit avec l'épulement de l'arbre (II) soit sans l'épulement de l'arbre
- L'arbre plein sans l'épulement de l'arbre est monté en utilisant la bague d'arrêt(A)
- L'arbre plein avec l'épulement de l'arbre est monté en utilisant la bague distancieuse

Elementos ds fijación

Este se utiliza para el diseño de engranajes montados. Debe indicarse cuando se pide por que existen los requisitos para el uso.

Condiciones de uso

- La perforación central debe ser apropiadamente maquinada DIN332/2
- El eje macizo debe montarse con el soporte del eje (II) o sin soporte del eje (I)
- El eje macizo sin soporte del eje se monta utilizando el anillo de retención (A)
- El eje macizo con el soporte del eje se monta utilizando el anillo distanciator

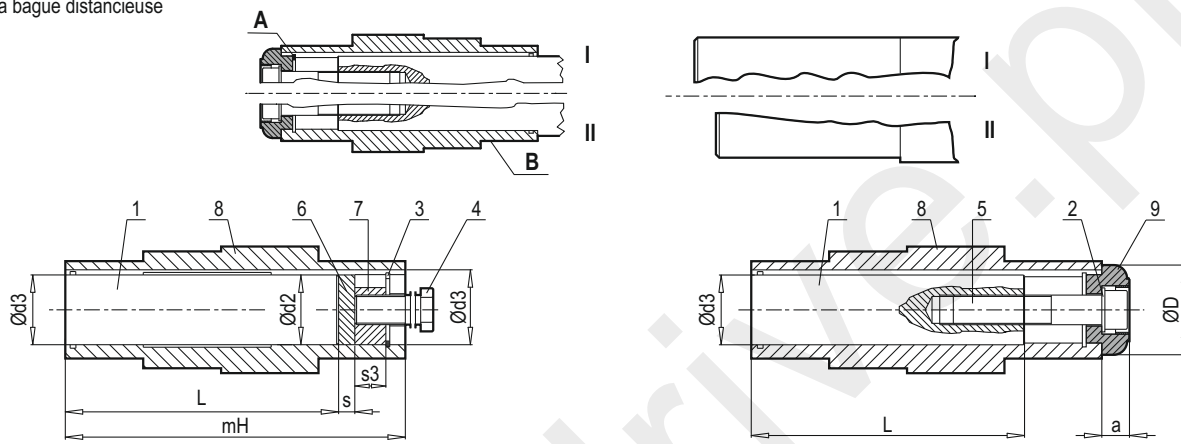

DISASSEMBLING / DESMONTAJE

L= Longueur max. de l'arbre à entraîner
L= longitud máxima del eje macizo

MONTAGE / MONTAJE

- 1) Arbre à entraîner
- 2) Rondelle à ressort DIN 127
- 3) * Circlip DIN 472
- 4) * Vis de démontage
- 5) Vis à tête cylindrique DIN 912
- 6) * Rondelle de pression
- 7) * Ecrou de démontage
- 8) Arbre creux
- 9) rondelle

*Ne font pas partie de la livraison, fournis en supplément.

- 1) El eje del cliente
- 2) Arandela DIN 127
- 3) * Anillo de seguridad DIN 472
- 4) * Tornillo extracción
- 5) Tornillo con cabezal hexagonal DIN 912
- 6) * Arandela de empuje
- 7) * Tuerca de levantamiento
- 8) Eje hueco
- 9) Disco

*Los artículos señalados con la estrella no son suministrados por NRW.

DÉMONTAGE

- 1) Desserrer la vis à tête creuse. (5)
- 2) Retirer la rondelle de poulie. (9)
- 3) Installer la rondelle élastique. (6)
- 4) Installer l'écrou. (7)
- 5) Installer le circlip. (3)
- 6) Retirez l'arbre plein de l'arbre creux à l'aide de la vis d'extraction. (4)

ASSEMBLAGE

- 1) L'arbre du client doit être installé à l'intérieur de l'arbre de la boîte de vitesses. (8)
- 2) La rondelle extracteur doit être installée à l'intérieur de l'arbre de la boîte de vitesses. (9)
- 3) Le boulon et la rondelle doivent être fixés avec la rondelle extracteur. (9-5-2)

Conditions d'utilisation (assemblage)

- L'arbre de l'utilisateur doit être fileté au centre conformément à la norme DIN 332/2.
- L'arbre de client ne doit pas dépasser la longueur "L", sinon le tiron ne peut pas être utilisé. Sinon, il ne sera pas possible d'utiliser les éléments de traction.(Pos. 3-6-7)

Conditions d'utilisation (pour le démontage)

- Les dimensions de démontage peuvent être prises en utilisant les normes d'usine.
- La procédure de démontage n'est valable que pour les arbres pleins dont la dimension n'excède pas "L" qui s'emboîtera dans l'arbre creux.

DESMONTAJE

- 1) Aflojar los tornillos de cabeza hueca (5)
- 2) Retirar la arandela extractora (9)
- 3) Instalar la arandela elástica (6)
- 4) Instalar la tuerca (7)
- 5) Instalar el anillo de ajuste (3)
- 6) Retirar el eje sólido del eje hueco usando un destornillador (4)

MONTAJE

- 1) El eje saliente debe montarse dentro del eje del reductor. (8)
- 2) Las arandelas extractoras deben montarse dentro del eje del reductor. (9)
- 3) El tornillo y la arandela debe estar fijada a la arandela extractora. (9-5-2)

Condiciones de uso (montaje)

- El eje debe roscarse al centro según DIN 322/2.
- El eje de salida no debe exceder la longitud, de lo contrario no se podrá aplicar el extractor. (pos. 3,6,7).

Condiciones de uso (desmontaje)

- Las dimensiones de desmontaje se pueden tomar utilizando los estándares de fábrica.
- El procedimiento de desmontaje solo es válido para ejes sólidos que se conectarán a ejes sólidos y dimensión no exceda la longitud.

DE ZUBEHÖR

FR ACCESSOIRES

EN ACCESSORIES

ES ACCESORIOS

IT ACCESSORI

Masse des Befestigungsbauteils / Dimensions of fixing element / Dimensioni degli elementi di fissaggio / Dimensions des élément de fixation / Dimensionos de los elementos de fijación (Ç)

Typ / Type / Tipo / Type / Tipo	1 L	2	3	4	5	6		7		8 d x mH	9		
						d2	s	d3	s3		a	D	
K 35390 DA-DG	110	A12	l 35 x 1.5	M16	M12 X 55	34.9	3	34.9	16	M16	35 x 140	24.5	45
K 40390 DA-DG	148	A16	l 40 x 2.0	M16	M16 X 70	39.9	4	39.9	16	M16	40 x 180	25	55
K 50390 DA-DG	170	A16	l 50 x 2.5	M20	M16 X 70	49.9	4	49.9	20	M20	50 x 210	26	65
K 60390 DA-DG	195	A20	l 60 x 3.0	M24	M20 X 90	59.9	5	59.9	24	M24	60 x 240	31	75
K 70390 DA	255	A20	l 70 x 3.0	M24	M20 X 90	69.9	5	69.9	24	M24	70 x 300	32	78
K 90390 DA	305	A24	l 90 x 4.0	M30	M24 X 110	89.9	8	89.9	22	M30	90 x 350	36	102
K 100390 DA	390	A24	l 100 x 4.0	M30	M24 X 110	99.9	8	99.9	30	M30	100 x 445	36.5	120

Die auf der Tafel aufgeführten Zahlen werden auf Seite 47-48 erläutert
The numbers which are specified at table are explained on Page 47-48.
I numeri che si trovano nella tabella sono espressi sulla pagina 47-48.
Les numéros qui se trouvent dans le tableau sont expliqués sur la page 47-48.
Los numeros que se halan en la tabla son expresados sobre la pagina 47-48.

Auswahltabellen der Getriebemotoren

Selection Tables of
Gearedmotors

Tabelle di selezione dei
motoriduttori

Tables de Gearedmotors de
sélection

Tablas de selección de
gearedmotors

K...
K35390 - K100390

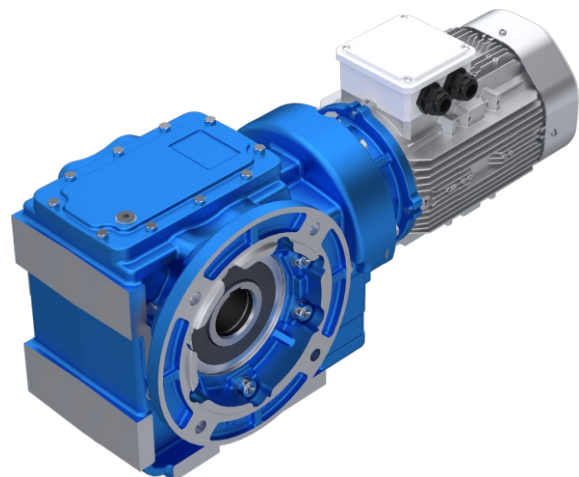
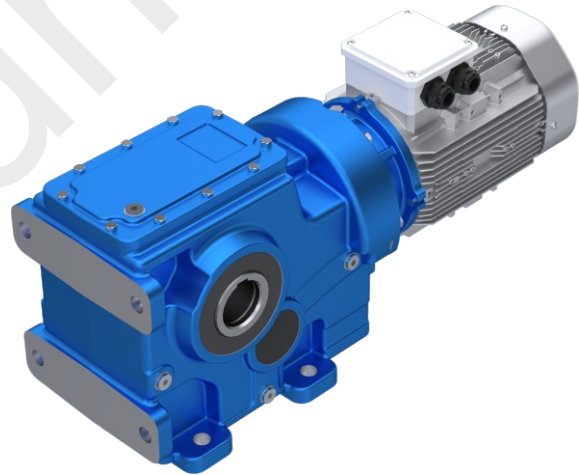
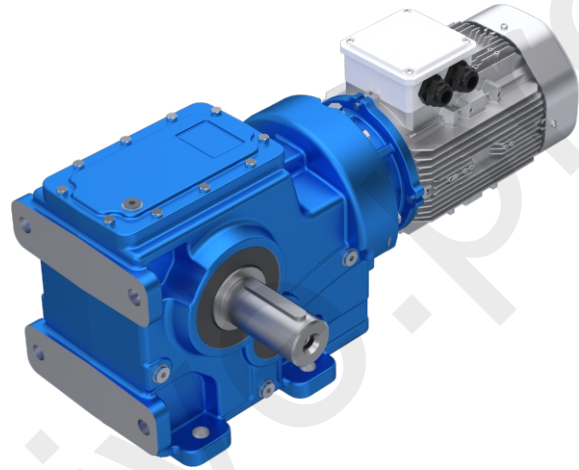

K...

DE TECHNISCHE BESCHREIBUNGEN
FR DESCRIPTIONS TECHNIQUES

EN TECHNICAL DESCRIPTIONS
ES DESCRIPCIONES TECNICAS

IT DESCRIZIONI TECNICHE

Aufbau der Leistungstafeln für Getriebemotor

Notify about performance tables for Geared motor.

Notificare sulle tabelle di performance per i motoriduttori

Aviser sur les tableaux de performance pour le motoréducteur

Notificar sobre la tabla de performance para los motoredutores.

0.37 kW →

Getriebe Motorleistung

Gear unit motor power

Potenza motore riduttore

Potencia del motor del reductor

Réducteur puissance du moteur

Zulässige Radialkraft

Permissible radial force

Force radiale admissible

Fuerza radial admisible

Forza radiale ammessa

P ₁ [kW]	n ₂ [Min ⁻¹]	M ₂ [Nm]	f _B	i _{ges}	FR (a) [kN]	FR (b) [kN]	Typ / Type / Tipo / Type / Tipo IE2 / IE3	kg ~	mm
0.37	5.7	595	1.1	158.67	12.0	6.7	K35390 - 80M6A	34	94
	6.4	526	1.2	140.25	12.0	6.5			
	7.2	470	1.3	125.18	12.0	5.3			
	8.0	423	1.5	112.63	12.0	6.1			
	8.8	383	1.6	102.00	12.0	5.9			
	9.9	342	1.8	91.04	12.0	5.7			
	11.5	293	2.2	78.09	12.0	5.4			
	12.9	262	2.4	69.70	12.0	5.2			
	15.7	215	2.9	57.38	12.0	4.9			

Vollwelle

Solid shaft

Albero pieno

Arbre en

Eje macizo

Hohlwelle / Schrumpfscheibe

Hollow shaft / Shrink disc shaft

Albero cavo / Albero calettatore

Arbre creux / Arbre avec frette

Eje hueco / Eje hueco con aro de apriete

Verkleinerungsfaktor

Reduction ratio

Rapporto di riduzione

Rapport de réduction

Relación de reducción

Getriebe Motortyp

Gear unit motor type

Réducteur type de moteur

Reductor tipo de motor

Riduttore tipo di motore

Servicefaktor

Service factor

Factor de servicio

Fattore di servizio

Facteur de service

Gewicht

Weight

peso

poids

peso

Abtriebsdrehmoment

Output torque

Coppia di uscita

Par de salida

Couple de sortie

Zeichnungsseite

Drawing page

Pagina di disegno

Page de dessin

Pagina de diseño

Abtriebsdrehzahl

Output speed

Vitesse de sortie

Velocità di uscita

Velocidad de salida



Motornennleistung



Rated motor power



Potenza nominale del motore



Puissance nominale du moteur

Potencia nominal del motor



P ₁ [kW]	n ₂ [Min ⁻¹]	M ₂ [Nm]	f _B	i _{ges}	FR (a) [kN]	FR (b) [kN]	Typ / Type / Tipo / Type / Tipo IE2 / IE3	 ~	 mm	
0.18	5.7	290	2.2	158.67	12.0	6.9	K35390 71M6B / 71M6A	33	94	
	6.4	256	2.5	140.25	12.0	6.7				
	7.2	228	2.8	125.18	12.0	6.4				
0.25	5.7	402	1.6	158.67	12.0	6.8	K35390 71M6C / 71M6D	33	94	
	6.4	356	1.8	140.25	12.0	6.6				
	7.2	317	2.0	125.18	12.0	6.4				
	8.0	286	2.2	112.63	12.0	6.2				
	8.8	259	2.4	102.00	12.0	6.0				
	9.9	231	2.7	91.04	12.0	5.7				
	8.8	254	2.4	158.67	12.0	6.8	K35390 71M4A / 71M4B	33	94	
	10.0	225	2.7	140.25	12.0	6.6				
	11.2	201	3.0	125.18	12.0	6.4				
0.37	5.7	595	1.1	158.67	12.0	6.7	K35390 80M6A	34	94	
	6.4	526	1.2	140.25	12.0	6.5				
	7.2	470	1.3	125.18	12.0	5.3				
	8.0	423	1.5	112.63	12.0	6.1				
	8.8	383	1.6	102.00	12.0	5.9				
	9.9	342	1.8	91.04	12.0	5.7				
	11.5	293	2.2	78.09	12.0	5.4				
	12.9	262	2.4	69.70	12.0	5.2				
	15.7	215	2.9	57.38	12.0	4.9				
		8.8	376	1.6	158.67	12.0	6.7	K35390 71M4B / 71M4C	33	94
		10.0	333	1.8	140.25	12.0	6.5			
		11.2	297	2.0	125.18	12.0	5.3			
		12.4	267	2.2	112.63	12.0	6.1			
		13.7	242	2.5	102.00	12.0	5.9			
		15.4	216	2.8	91.04	12.0	5.7			
	17.6	180	2.5	158.67	12.0	6.7	K35390 71M2A	33	94	
	20.0	159	2.9	140.25	12.0	6.5				
0.55	5.6	899	2.1	161.23	22.0	12.9	K50390 80M6B	57	98	
	6.4	787	2.4	141.14	22.0	12.3				
	6.9	723	2.6	129.64	22.0	11.9				
	7.7	655	2.9	117.49	22.0	11.5				
	8.0	624	3.0	111.93	22.0	11.4				
		6.3	793	1.1	142.18	18.0	10.0	K40390 80M6B	39	96
		7.2	694	1.3	124.46	18.0	9.6			
		7.9	637	1.4	114.17	18.0	9.3			
		8.7	577	1.5	103.40	18.0	9.1			
		9.1	550	1.6	98.70	18.0	8.9			
		9.9	505	1.8	90.52	18.0	8.7			
		11.4	442	2.0	79.26	18.0	8.4			
		12.5	400	2.2	71.78	18.0	8.1			
		13.3	378	2.4	67.78	18.0	8.0			
		14.4	348	2.6	62.47	18.0	7.8			
		15.3	328	2.7	58.81	18.0	7.5			
		16.5	304	2.9	54.43	18.0	7.4			
		9.8	501	1.7	142.18	18.0	10.0	K40390 80M4B / 80M4C	39	96
		11.2	439	1.9	124.46	18.0	9.6			
		12.3	403	2.1	114.17	18.0	9.3			
		13.5	365	2.3	103.40	18.0	9.1			
		14.2	348	2.4	98.70	18.0	8.9			
		15.5	319	2.7	90.52	18.0	8.7			
		17.7	280	3.0	79.26	18.0	8.4			
		6.4	782	0.8	140.25	12.0	6.3	K35390 80M6B	34	94
		7.2	698	0.9	125.18	12.0	6.1			
		8.0	628	1.0	112.63	12.0	5.9			
		8.8	569	1.1	102.00	12.0	5.7			
		9.9	508	1.2	91.04	12.0	5.6			
		11.5	436	1.4	78.09	12.0	5.3			
	12.9	389	1.6	69.70	12.0	5.1				
	15.7	320	2.0	57.38	12.0	4.9				
	17.6	286	2.2	51.21	12.0	4.7				
	20.7	243	2.6	43.56	12.0	4.4				
	23.1	217	2.9	38.88	12.0	4.3				



P ₁ [kW]	n ₂ [Min ⁻¹]	M ₂ [Nm]	f _B	i _{ges}	FR (a) [kN]	FR (b) [kN]	Typ / Type / Tipo / Type / Tipo IE2 / IE3	 ~				
0.55	8.8	560	1.1	158.67	12.0	6.5	K35390 80M4B / 80M4C	34	94			
	10.0	495	1.2	140.25	12.0	6.3						
	11.2	441	1.4	125.18	12.0	6.1						
	12.4	397	1.5	112.63	12.0	5.9						
	13.7	360	1.7	102.00	12.0	5.7						
	15.4	321	1.9	91.04	12.0	5.6						
	17.9	275	2.2	78.09	12.0	5.3						
	20.1	246	2.4	69.70	12.0	5.1						
	24.4	202	3.0	57.38	12.0	4.9						
	17.6	267	1.7	158.67	12.0	6.5	K35390 71M2B	33	94			
	20.0	236	1.9	140.25	12.0	6.3						
	22.4	211	2.2	125.18	12.0	6.1						
	24.9	190	2.4	112.63	12.0	5.9						
	27.5	172	2.7	102.00	12.0	5.7						
	30.8	153	3.0	91.04	12.0	5.6						
	0.75	5.6	1226	1.5	161.23	22.0	12.7	K50390 90S6B / 90L6C	62	98		
6.4		1073	1.8	141.14	22.0	12.2						
6.9		986	1.9	129.64	22.0	11.9						
7.7		894	2.1	117.49	22.0	11.5						
8.0		851	2.2	111.93	22.0	11.4						
8.7		782	2.4	102.86	22.0	11.1						
10.0		684	2.8	90.00	22.0	10.5						
11.0		620	3.0	81.57	22.0	10.2						
8.7		775	2.3	161.23	22.0	12.7	K50390 80M4C / 80M4D				57	98
9.9		679	2.7	141.14	22.0	12.2						
10.8		623	2.9	129.64	22.0	11.9						
6.3		1081	0.8	142.18	18.0	9.8	K40390 90S6B / 90L6C	44	96			
7.2		947	0.9	124.46	18.0	9.4						
7.9		868	1.0	114.17	18.0	9.2						
8.7		786	1.1	103.40	18.0	8.9						
9.1		751	1.2	98.70	18.0	8.8						
9.9		688	1.3	90.52	18.0	8.6						
11.4		603	1.5	79.26	18.0	8.2						
12.5		546	1.6	71.78	18.0	8.0						
13.3		516	1.7	67.78	18.0	7.9						
14.4		475	1.9	62.47	18.0	7.7						
15.3		447	2.0	58.81	18.0	7.5						
16.5		414	2.2	54.43	18.0	7.4						
17.9		382	2.3	50.17	18.0	7.2						
20.1		341	2.6	44.78	18.0	6.8						
21.3		322	2.8	42.28	18.0	6.7						
23.1		296	3.0	38.97	18.0	6.5						
9.8		684	1.2	142.18	18.0	9.8	K40390 80M4C / 80M4D	39	96			
11.2		599	1.4	124.46	18.0	9.4						
12.3		549	1.5	114.17	18.0	9.2						
13.5		497	1.7	103.40	18.0	8.9						
14.2		475	1.8	98.70	18.0	8.8						
15.5		435	2.0	90.52	18.0	8.6						
17.7		381	2.2	79.26	18.0	8.2						
19.5		345	2.5	71.78	18.0	8.0						
20.7		326	2.6	67.78	18.0	7.9						
22.4	300	2.8	62.47	18.0	7.7							
23.8	283	3.0	58.81	18.0	7.5							
19.7	327	2.0	142.18	18.0	9.8	K40390 80M2B / 80M2C				39	96	
22.5	286	2.3	124.46	18.0	9.4							
24.5	262	2.5	114.17	18.0	9.2							
27.1	238	2.7	103.40	18.0	8.9							
28.4	227	2.8	98.70	18.0	8.8							
11.5	594	1.1	78.09	12.0	5.2	K35390 90S6B / 90L6C	39	94				
12.9	530	1.2	69.70	12.0	5.0							
15.7	436	1.4	57.38	12.0	4.8							
17.6	389	1.6	51.21	12.0	4.6							
20.7	331	1.9	43.56	12.0	4.4							
23.1	296	2.1	38.88	12.0	4.3							
26.7	256	2.5	33.70	12.0	4.1							
31.9	215	2.9	28.25	12.0	3.8							



P ₁ [kW]	n ₂ [Min ⁻¹]	M ₂ [Nm]	f _B	i _{ges}	FR (a) [kN]	FR (b) [kN]	Typ / Type / Tipo / Type / Tipo IE2 / IE3	 ~	 mm			
0.75	8.8	763	0.8	158.67	12.0	6.5	K35390 80M4C / 80M4D	34	94			
	10.0	674	0.9	140.25	12.0	6.0						
	11.2	602	1.0	125.18	12.0	5.9						
	12.4	542	1.1	112.63	12.0	5.7						
	13.7	491	1.2	102.00	12.0	5.6						
	15.4	438	1.4	91.04	12.0	5.4						
	17.9	376	1.6	78.09	12.0	5.2						
	20.1	335	1.8	69.70	12.0	5.0						
	24.4	276	2.2	57.38	12.0	4.8						
	27.3	246	2.4	51.21	12.0	4.6						
	32.1	209	2.9	43.56	12.0	4.4						
	17.6	365	1.3	158.67	12.0	6.5				K35390 80M2B / 80M2C	34	94
	20.0	322	1.4	140.25	12.0	6.0						
	22.4	288	1.6	125.18	12.0	5.9						
24.9	259	1.8	112.63	12.0	5.7							
27.5	234	1.9	102.00	12.0	5.6							
30.8	209	2.2	91.04	12.0	5.4							
35.9	180	2.5	78.09	12.0	5.2							
40.2	160	2.8	69.70	12.0	5.0							
1.10	4.9	2042	1.8	183.08	30.0	17.8	K60390 90L6C / 90L6D	89	100			
	5.5	1814	2.0	162.63	30.0	17.3						
	6.1	1635	2.2	146.59	30.0	16.8						
	6.8	1472	2.5	131.96	30.0	16.3						
	7.4	1354	2.7	121.39	30.0	15.5						
	8.3	1208	3.0	108.31	30.0	15.0						
	5.6	1798	1.1	161.23	22.0	12.4	K50390 90L6C / 90L6D	62	98			
	6.4	1574	1.2	141.14	22.0	11.9						
	6.9	1446	1.3	129.64	22.0	11.7						
	7.7	1311	1.4	117.49	22.0	11.3						
	8.0	1249	1.5	111.93	22.0	11.2						
	8.7	1147	1.6	102.86	22.0	10.9						
	10.0	1004	1.9	90.00	22.0	10.5						
	11.0	910	2.1	81.57	22.0	10.2						
	11.7	857	2.2	76.87	22.0	10.0						
	12.7	790	2.3	70.84	22.0	9.7						
	13.5	745	2.4	66.83	22.0	9.6						
	14.1	713	2.5	63.93	22.0	9.4						
	15.8	635	2.8	56.96	22.0	9.0						
	8.7	1137	1.6	161.23	22.0	12.4	K50390 90L4B / 90L4C	62	98			
	9.9	996	1.8	141.14	22.0	11.9						
	10.8	914	2.0	129.64	22.0	11.7						
	11.9	829	2.2	117.49	22.0	11.3						
	12.5	789	2.3	111.93	22.0	11.2						
	13.6	726	2.5	102.86	22.0	10.9						
	15.6	635	2.8	90.00	22.0	10.5						
	17.4	544	2.5	161.23	22.0	12.4	K50390 80M2C / 80M2D	57	98			
	19.8	476	2.9	141.14	22.0	11.9						
	8.7	1153	0.8	103.40	18.0	8.7	K40390 90L6C / 90L6D	44	96			
	9.1	1101	0.8	98.70	18.0	8.6						
	9.9	1010	0.9	90.52	18.0	8.4						
	11.4	884	1.0	79.26	18.0	8.0						
	12.5	801	1.1	71.78	18.0	7.8						
	13.3	756	1.2	67.78	18.0	7.7						
14.4	697	1.3	62.47	18.0	7.5							
15.3	656	1.4	58.81	18.0	7.4							
16.5	607	1.5	54.43	18.0	7.2							
17.9	560	1.6	50.17	18.0	7.1							
20.1	500	1.8	44.78	18.0	6.8							
21.3	472	1.9	42.28	18.0	6.7							
23.1	435	2.1	38.97	18.0	6.5							
26.5	379	2.4	33.95	18.0	6.3							
28.8	349	2.6	31.29	18.0	6.1							
31.8	316	2.8	28.33	18.0	5.9							



P ₁ [kW]	n ₂ [Min ⁻¹]	M ₂ [Nm]	f _B	i _{ges}	FR (a) [kN]	FR (b) [kN]	Typ / Type / Tipo / Type / Tipo IE2 / IE3	 ~	 mm			
1.10	9.8	1003	0.8	142.18	18.0	9.8	K40390 90L4B / 90L4C	44	96			
	11.2	878	1.0	124.46	18.0	9.1						
	12.3	805	1.1	114.17	18.0	8.9						
	13.5	729	1.2	103.40	18.0	8.7						
	14.2	696	1.2	98.70	18.0	8.6						
	15.5	638	1.3	90.52	18.0	8.4						
	17.7	559	1.5	79.26	18.0	8.0						
	19.5	506	1.7	71.78	18.0	7.8						
	20.7	478	1.8	67.78	18.0	7.7						
	22.4	441	1.9	62.47	18.0	7.5						
	23.8	415	2.0	58.81	18.0	7.4						
	25.7	384	2.2	54.43	18.0	7.2						
	27.9	354	2.4	50.17	18.0	7.1						
	31.3	316	2.7	44.78	18.0	6.8						
	33.1	298	2.9	42.28	18.0	6.7						
	19.7	479	1.3	142.18	18.0	9.8	K40390 80M2C / 80M2D	39	96			
	22.5	420	1.5	124.46	18.0	9.1						
	24.5	385	1.7	114.17	18.0	8.9						
	27.1	349	1.9	103.40	18.0	8.7						
	28.4	333	1.9	98.70	18.0	8.6						
	30.9	305	2.1	90.52	18.0	8.4						
	35.3	267	2.4	79.26	18.0	8.0						
	39.0	242	2.7	71.78	18.0	7.8						
	41.3	229	2.8	67.78	18.0	7.7						
	12.9	777	0.8	69.70	12.0	4.8	K35390 90L6C / 90L6D	39	94			
	15.7	640	1.0	57.38	12.0	4.6						
	17.6	571	1.1	51.21	12.0	4.5						
	20.7	486	1.3	43.56	12.0	4.3						
	23.1	434	1.5	38.88	12.0	4.1						
	26.7	376	1.7	33.70	12.0	4.0						
	31.9	315	2.0	28.25	12.0	3.8						
	34.2	293	2.1	26.30	12.0	3.7						
	40.0	251	2.5	22.50	12.0	3.5						
	17.9	551	1.1	78.09	12.0	5.0	K35390 90L4B / 90L4C	39	94			
	20.1	492	1.2	69.70	12.0	4.8						
	24.4	405	1.5	57.38	12.0	4.6						
27.3	361	1.7	51.21	12.0	4.5							
32.1	307	2.0	43.56	12.0	4.3							
36.0	274	2.2	38.88	12.0	4.1							
41.5	238	2.5	33.70	12.0	4.0							
49.6	199	3.0	28.25	12.0	3.8							
17.6	535	0.9	158.67	12.0	6.5	K35390 80M2C / 80M2D	34	94				
20.0	473	1.0	140.25	12.0	6.0							
22.4	422	1.1	125.18	12.0	5.9							
24.9	380	1.2	112.63	12.0	5.7							
27.5	344	1.3	102.00	12.0	5.6							
30.8	307	1.5	91.04	12.0	5.2							
35.9	263	1.7	78.09	12.0	5.0							
40.2	235	1.9	69.70	12.0	4.8							
48.8	193	2.4	57.38	12.0	4.6							
54.7	173	2.6	51.21	12.0	4.5							
1.50	4.9	2788	1.9	183.27	45.0				45.0	K70390 100L6C / 100L6D	141	102
	5.5	2479	2.1	162.98	45.0	45.0						
	6.1	2227	2.4	146.38	45.0	45.0						
	6.7	2031	2.6	133.53	45.0	45.0						
	7.4	1855	2.8	121.96	45.0	45.0						
	4.9	2785	1.3	183.08	30.0	17.3	K60390 100L6C / 100L6D	99	100			
	5.5	2474	1.5	162.63	30.0	16.7						
	6.1	2230	1.6	146.59	30.0	16.3						
	6.8	2007	1.8	131.96	30.0	15.9						
	7.4	1846	2.0	121.39	30.0	15.5						
	8.3	1648	2.2	108.31	30.0	15.0						
	8.9	1541	2.4	101.29	30.0	14.2						
	9.9	1389	2.6	91.30	30.0	13.8						
	11.1	1235	3.0	81.18	30.0	13.4						



P ₁ [kW]	n ₂ [Min ⁻¹]	M ₂ [Nm]	f _B	i _{ges}	FR (a) [kN]	FR (b) [kN]	Typ / Type / Tipo / Type / Tipo IE2 / IE3	~ Kg	 mm
1.50	8.6	1564	2.2	162.63	30.0	16.7	K60390 90L4C / 90L4D	89	100
	9.6	1410	2.5	146.59	30.0	16.3			
	10.6	1269	2.8	131.96	30.0	15.9			
	11.5	1168	3.0	121.39	30.0	15.5			
	5.6	2452	0.8	161.23	22.0	12.1	K50390 100L6C / 100L6D	72	98
	6.4	2147	0.9	141.14	22.0	11.7			
	6.9	1972	1.0	129.64	22.0	11.4			
	7.7	1787	1.1	117.49	22.0	11.1			
	8.0	1703	1.1	111.93	22.0	10.9			
	8.7	1565	1.2	102.86	22.0	10.7			
	10.0	1369	1.4	90.00	22.0	10.3			
	11.0	1241	1.5	81.57	22.0	10.0			
	11.7	1169	1.6	76.87	22.0	9.8			
	12.7	1078	1.7	70.84	22.0	9.6			
	13.5	1017	1.8	66.83	22.0	9.4			
	14.1	972	1.8	63.93	22.0	9.3			
	15.8	866	2.1	56.96	22.0	9.0			
	17.4	785	2.3	51.63	22.0	8.7			
	18.4	744	2.4	48.89	22.0	8.6			
	19.3	709	2.5	46.59	22.0	8.4			
	20.5	668	2.7	43.91	22.0	8.1			
	22.2	615	2.9	40.46	22.0	7.9			
	8.7	1551	1.2	161.23	22.0	12.1	K50390 90L4C / 90L4D	62	98
	9.9	1358	1.3	141.14	22.0	11.7			
	10.8	1247	1.4	129.64	22.0	11.4			
	11.9	1130	1.6	117.49	22.0	11.1			
	12.5	1077	1.7	111.93	22.0	10.9			
	13.6	989	1.8	102.86	22.0	10.7			
	15.6	866	2.1	90.00	22.0	10.3			
	17.2	785	2.3	81.57	22.0	10.0			
	18.2	739	2.4	76.87	22.0	9.8			
	19.8	681	2.5	70.84	22.0	9.6			
	20.9	643	2.6	66.83	22.0	9.4			
	21.9	615	2.8	63.93	22.0	9.3			
	17.4	741	1.8	161.23	22.0	12.1	K50390 90L2B / 90L2C	62	98
	19.8	649	2.1	141.14	22.0	11.7			
	21.6	596	2.3	129.64	22.0	11.4			
	23.8	540	2.5	117.49	22.0	11.1			
	25.0	515	2.7	111.93	22.0	10.9			
	27.2	473	2.9	102.86	22.0	10.7			
	12.5	1092	0.8	71.78	18.0	7.6	K40390 100L6C / 100L6D	54	96
	13.3	1031	0.9	67.78	18.0	7.5			
	14.4	950	0.9	62.47	18.0	7.3			
	15.3	895	1.0	58.81	18.0	7.2			
	16.5	828	1.1	54.43	18.0	7.1			
	17.9	763	1.2	50.17	18.0	6.9			
	20.1	681	1.3	44.78	18.0	6.7			
	21.3	643	1.4	42.28	18.0	6.6			
	23.1	593	1.5	38.97	18.0	6.4			
	26.5	516	1.7	33.95	18.0	6.2			
	28.8	476	1.9	31.29	18.0	6.0			
	31.8	431	2.1	28.33	18.0	5.9			
	34.5	397	2.2	26.11	18.0	5.7			
	40.2	341	2.6	22.40	18.0	5.3			
	12.3	1098	0.8	114.17	18.0	8.9	K40390 90L4C / 90L4D	44	96
	13.5	995	0.9	103.40	18.0	8.7			
	14.2	949	0.9	98.70	18.0	8.3			
	15.5	871	1.0	90.52	18.0	8.1			
	17.7	762	1.1	79.26	18.0	7.8			
	19.5	690	1.2	71.78	18.0	7.6			
	20.7	652	1.3	67.78	18.0	7.5			
	22.4	601	1.4	62.47	18.0	7.3			
	23.8	566	1.5	58.81	18.0	7.2			
	25.7	524	1.6	54.43	18.0	7.1			
	27.9	483	1.8	50.17	18.0	6.9			
	31.3	431	2.0	44.78	18.0	6.7			
	33.1	407	2.1	42.28	18.0	6.6			
	35.9	375	2.3	38.97	18.0	6.4			
	41.2	327	2.6	33.95	18.0	6.2			
	44.7	301	2.8	31.29	18.0	6.0			



P ₁ [kW]	n ₂ [Min ⁻¹]	M ₂ [Nm]	f _B	i _{ges}	FR (a) [kN]	FR (b) [kN]	Typ / Type / Tipo / Type / Tipo IE2 / IE3	 ~	 mm			
1.50	19.7	654	1.0	142.18	18.0	9.8	K40390 90L2B / 90L2C	44	96			
	22.5	572	1.1	124.46	18.0	9.1						
	24.5	525	1.2	114.17	18.0	8.9						
	27.1	475	1.4	103.40	18.0	8.7						
	28.4	454	1.4	98.70	18.0	8.3						
	30.9	416	1.6	90.52	18.0	8.1						
	35.3	364	1.8	79.26	18.0	7.8						
	39.0	330	2.0	71.78	18.0	7.6						
	41.3	312	2.1	67.78	18.0	7.5						
	44.8	287	2.2	62.47	18.0	7.3						
	47.6	270	2.4	58.81	18.0	7.2						
	51.2	252	2.6	54.72	18.0	7.1						
	55.8	231	2.8	50.17	18.0	6.9						
	17.6	779	0.8	51.21	12.0	4.3				K35390 100L6C / 100L6D	49	94
	20.7	663	1.0	43.56	12.0	4.1						
	23.1	591	1.1	38.88	12.0	4.0						
	26.7	513	1.2	33.70	12.0	3.9						
	31.9	430	1.5	28.25	12.0	3.7						
	34.2	400	1.6	26.30	12.0	3.6						
	40.0	342	1.8	22.50	12.0	3.5						
	52.7	260	2.4	17.08	12.0	3.2						
	59.0	232	2.7	15.25	12.0	3.0						
	17.9	751	0.8	78.09	12.0	5.0	K35390 90L4C / 90L4D	39	94			
	20.1	670	0.9	69.70	12.0	4.6						
	24.4	552	1.1	57.38	12.0	4.4						
	27.3	493	1.2	51.21	12.0	4.3						
	32.1	419	1.4	43.56	12.0	4.1						
	36.0	374	1.6	38.88	12.0	4.0						
	41.5	324	1.9	33.70	12.0	3.9						
	49.6	272	2.2	28.25	12.0	3.7						
	53.2	253	2.4	26.30	12.0	3.6						
	62.2	216	2.8	22.50	12.0	3.5						
	22.4	576	0.8	125.18	12.0	5.9	K35390 90L2B / 90L2C	39	94			
	24.9	518	0.9	112.63	12.0	5.7						
	27.5	469	1.0	102.00	12.0	5.6						
	30.8	419	1.1	91.04	12.0	5.4						
35.9	359	1.3	78.09	12.0	5.0							
40.2	320	1.4	69.70	12.0	4.6							
48.8	264	1.7	57.38	12.0	4.4							
54.7	235	1.9	51.21	12.0	4.3							
64.3	200	2.3	43.56	12.0	4.1							
72.0	179	2.6	38.88	12.0	4.0							
83.1	155	2.9	33.70	12.0	3.9							
2.20	4.9	4089	1.3	183.27	45.0	45.0				K70390 112M6C / 112M6D	149	102
	5.5	3636	1.4	162.98	45.0	45.0						
	6.1	3266	1.6	146.38	45.0	45.0						
	6.7	2979	1.8	133.53	45.0	45.0						
	7.4	2721	1.9	121.96	45.0	45.0						
	8.2	2444	2.1	109.54	45.0	45.0						
	8.6	2335	2.2	104.68	45.0	45.0						
	9.7	2077	2.5	93.09	45.0	45.0						
	10.8	1866	2.8	83.66	45.0	45.0						
	7.6	2585	1.9	183.27	45.0	45.0	K70390 100L4B / 100L4C	141	102			
	8.6	2299	2.2	162.98	45.0	45.0						
	9.6	2065	2.4	146.38	45.0	45.0						
	10.5	1884	2.7	133.53	45.0	45.0						
	11.5	1720	2.9	121.96	45.0	45.0						



P ₁ [kW]	n ₂ [Min ⁻¹]	M ₂ [Nm]	f _B	i _{ges}	FR (a) [kN]	FR (b) [kN]	Typ / Type / Tipo / Type / Tipo IE2 / IE3	 Kg ~	 mm	
2.20	4.9	4084	0.9	183.08	30.0	16.2	K60390 112M6C / 112M6D	107	100	
	5.5	3628	1.0	162.63	30.0	15.8				
	6.1	3270	1.1	146.59	30.0	15.5				
	6.8	2944	1.2	131.96	30.0	15.1				
	7.4	2708	1.4	121.39	30.0	14.8				
	8.3	2416	1.5	108.31	30.0	14.4				
	8.9	2260	1.6	101.29	30.0	14.2				
	9.9	2037	1.8	91.30	30.0	13.8				
	11.1	1811	2.0	81.18	30.0	13.4				
	11.9	1687	2.2	75.60	30.0	13.2				
	12.7	1576	2.2	70.62	30.0	12.9				
	14.1	1420	2.4	63.65	30.0	12.5				
	14.9	1346	2.5	60.34	30.0	12.4				
	16.3	1233	2.7	55.28	30.0	11.7				
	17.8	1128	3.0	50.56	30.0	11.5				
		8.6	2294	1.5	162.63	30.0	15.8	K60390 100L4B / 100L4C	99	100
		9.6	2068	1.7	146.59	30.0	15.5			
		10.6	1862	1.9	131.96	30.0	15.1			
		11.5	1712	2.0	121.39	30.0	14.8			
		12.9	1528	2.3	108.31	30.0	14.4			
		13.8	1429	2.4	101.29	30.0	14.2			
		15.3	1234	2.2	183.08	30.0	16.2	K60390 90L2D	89	100
		17.2	1097	2.4	162.63	30.0	15.8			
		19.1	988	2.7	146.59	30.0	15.5			
		21.2	890	3.0	131.96	30.0	15.1			
		8.0	2497	0.8	111.93	22.0	10.5	K50390 112M6C / 112M6D	80	98
		8.7	2295	0.8	102.86	22.0	10.3			
		10.0	2008	0.9	90.00	22.0	10.0			
		11.0	1820	1.0	81.57	22.0	9.7			
		11.7	1715	1.1	76.87	22.0	9.5			
		12.7	1580	1.1	70.84	22.0	9.3			
		13.5	1491	1.2	66.83	22.0	9.2			
		14.1	1426	1.3	63.93	22.0	9.0			
		15.8	1271	1.4	56.96	22.0	8.8			
		17.4	1152	1.5	51.63	22.0	8.5			
		18.4	1091	1.6	48.89	22.0	8.4			
		19.3	1039	1.7	46.59	22.0	8.3			
		20.5	980	1.8	43.91	22.0	8.1			
		22.2	903	2.0	40.46	22.0	7.9			
		25.5	788	2.3	35.30	22.0	7.6			
		27.7	726	2.5	32.54	22.0	7.4			
		30.3	662	2.5	29.67	22.0	7.3			
	35.1	572	2.8	25.65	22.0	6.8				
	38.7	519	2.8	23.26	22.0	6.6				
	8.7	2274	0.8	161.23	22.0	12.1				
	9.9	1991	0.9	141.14	22.0	11.1				
	10.8	1829	1.0	129.64	22.0	10.9				
	11.9	1657	1.1	117.49	22.0	10.7				
	12.5	1579	1.1	111.93	22.0	10.5				
	13.6	1451	1.2	102.86	22.0	10.3				
	15.6	1270	1.4	90.00	22.0	10.0				
	17.2	1151	1.6	81.57	22.0	9.7				
	18.2	1084	1.7	76.87	22.0	9.5				
	19.8	999	1.7	70.84	22.0	9.3				
	20.9	943	1.8	66.83	22.0	9.2				
	21.9	902	1.9	63.93	22.0	9.0				
	24.6	804	2.1	56.96	22.0	8.8				
	27.1	728	2.3	51.63	22.0	8.5				
	28.6	690	2.5	48.89	22.0	8.4				
	30.0	657	2.6	46.59	22.0	8.3				
	31.9	619	2.7	43.91	22.0	8.1				
	34.6	571	3.0	40.46	22.0	7.9				

P ₁ [kW]	n ₂ [Min ⁻¹]	M ₂ [Nm]	f _B	i _{ges}	FR (a) [kN]	FR (b) [kN]	Typ / Type / Tipo / Type / Tipo IE2 / IE3	 ~	 mm
2.20	17.4	1087	1.3	161.23	22.0	12.1	K50390 90L2D	62	98
	19.8	952	1.4	141.14	22.0	11.1			
	21.6	874	1.6	129.64	22.0	10.9			
	23.8	792	1.7	117.49	22.0	10.7			
	25.0	755	1.8	111.93	22.0	10.5			
	27.2	694	2.0	102.86	22.0	10.3			
	31.1	607	2.3	90.00	22.0	10.0			
	34.3	550	2.5	81.57	22.0	9.7			
	36.4	518	2.5	76.87	22.0	9.5			
	39.5	478	2.7	70.84	22.0	9.3			
	41.9	451	2.9	66.83	22.0	9.2			
	43.8	431	3.0	63.93	22.0	9.0			
	17.9	1119	0.8	50.17	18.0	6.7	K40390 112M6C / 112M6D	62	96
	20.1	999	0.9	44.78	18.0	6.5			
	21.3	943	0.9	42.28	18.0	6.4			
	23.1	869	1.0	38.97	18.0	6.2			
	26.5	757	1.2	33.95	18.0	6.0			
	28.8	698	1.3	31.29	18.0	5.9			
	31.8	632	1.4	28.33	18.0	5.7			
	34.5	583	1.5	26.11	18.0	5.6			
	40.2	500	1.8	22.40	18.0	5.3			
	50.1	401	2.2	17.98	18.0	5.0			
	55.2	363	2.5	16.29	18.0	4.9			
	63.8	315	2.7	14.11	18.0	4.6			
	87.7	229	3.0	10.26	18.0	4.2			
	115.1	174	3.0	7.82	18.0	3.8			
	17.7	1118	0.8	79.26	18.0	7.8			
	19.5	1013	0.8	71.78	18.0	7.6			
	20.7	956	0.9	67.78	18.0	7.2			
	22.4	881	1.0	62.47	18.0	7.0			
	23.8	830	1.0	58.81	18.0	6.9			
	25.7	768	1.1	54.43	18.0	6.8			
	27.9	708	1.2	50.17	18.0	6.7			
	31.3	632	1.3	44.78	18.0	6.5			
	33.1	596	1.4	42.28	18.0	6.4			
	35.9	550	1.5	38.97	18.0	6.2			
	41.2	479	1.8	33.95	18.0	6.0			
	44.7	441	1.9	31.29	18.0	5.9			
	49.4	400	2.1	28.33	-	5.7			
	53.6	368	2.3	26.11	18.0	5.6			
	62.5	316	2.7	22.40	18.0	5.3			
	22.5	839	0.8	124.46	18.0	9.1	K40390 90L2D	44	96
	24.5	770	0.8	114.17	18.0	8.9			
	27.1	697	0.9	103.40	18.0	8.7			
	28.4	666	1.0	98.70	18.0	8.3			
	30.9	610	1.1	90.52	18.0	8.1			
	35.3	534	1.2	79.26	18.0	7.8			
	39.0	484	1.3	71.78	18.0	7.6			
	41.3	457	1.4	67.78	18.0	7.2			
	44.8	421	1.5	62.47	18.0	7.0			
	47.6	397	1.6	58.81	18.0	6.9			
	51.2	369	1.8	54.72	18.0	6.8			
	55.8	338	1.9	50.17	18.0	6.7			
	62.5	302	2.1	44.78	18.0	6.5			
	66.2	285	2.3	42.28	18.0	6.4			
	71.9	263	2.5	38.97	18.0	6.2			
	82.5	229	2.8	33.95	18.0	6.0			
	26.7	752	0.8	33.70	12.0	3.7	K35390 112M6C / 112M6D	57	94
	31.9	630	1.0	28.25	12.0	3.5			
	34.2	587	1.1	26.30	12.0	3.5			
	40.0	502	1.3	22.50	11.7	3.3			
	52.7	381	1.7	17.08	10.9	3.1			
	59.0	340	1.8	15.25	10.6	3.0			
	68.1	295	2.1	13.21	12.0	2.9			
	72.5	277	2.2	12.41	12.0	2.9			
	81.2	247	2.3	11.08	12.0	2.8			
	87.3	230	2.4	10.31	12.0	2.7			
	97.8	205	2.4	9.20	12.0	2.6			
	122.3	164	2.2	7.36	12.0	2.4			
	130.2	154	2.3	6.91	12.0	2.4			
	156.8	128	2.4	5.74	12.0	2.3			



P ₁ [kW]	n ₂ [Min ⁻¹]	M ₂ [Nm]	f _B	i _{ges}	FR (a) [kN]	FR (b) [kN]	Typ / Type / Tipo / Type / Tipo IE2 / IE3	 ~	 mm			
2.20	27.3	722	0.8	51.21	12.0	4.2	K35390 100L4B / 100L4C	49	94			
	32.1	614	1.0	43.56	12.0	3.9						
	36.0	548	1.1	38.88	12.0	3.8						
	41.5	475	1.3	33.70	12.0	3.7						
	49.6	399	1.5	28.25	12.0	3.5						
	53.2	371	1.6	26.30	12.0	3.5						
	62.2	317	1.9	22.50	11.7	3.3						
	82.0	241	2.5	17.08	10.9	3.1						
	91.8	215	2.7	15.25	10.6	3.0						
	35.9	527	0.9	78.09	12.0	5.0				K35390 90L2D	39	94
	40.2	470	1.0	69.70	12.0	4.6						
	48.8	387	1.2	57.38	12.0	4.4						
	54.7	345	1.3	51.21	12.0	4.3						
	64.3	294	1.6	43.56	12.0	3.9						
	72.0	262	1.7	38.88	12.0	3.8						
	83.1	227	2.0	33.70	12.0	3.7						
	99.1	190	2.4	28.25	12.0	3.5						
	106.5	177	2.6	26.30	12.0	3.5						
	124.4	152	3.0	22.50	12.0	3.3						
3.00	4.9	5575	0.9	183.27	45.0	45.0	K70390 132S6A	171	102			
	5.5	4958	1.1	162.98	45.0	45.0						
	6.1	4453	1.2	146.38	45.0	45.0						
	6.7	4062	1.3	133.53	45.0	45.0						
	7.4	3710	1.4	121.96	45.0	45.0						
	8.2	3332	1.6	109.54	45.0	45.0						
	8.6	3185	1.6	104.68	45.0	45.0						
	9.7	2832	1.9	93.09	45.0	45.0						
	10.8	2545	2.1	83.66	45.0	45.0						
	11.8	2320	2.3	76.27	45.0	45.0						
	12.9	2119	2.5	69.66	45.0	45.0						
	14.2	1928	2.7	63.37	45.0	45.0						
	15.4	1774	3.0	58.32	45.0	44.1						
	7.6	3525	1.4	183.27	45.0	45.0				K70390 100L4C / 100L4D	141	102
	8.6	3135	1.6	162.98	45.0	45.0						
	9.6	2816	1.8	146.38	45.0	45.0						
	10.5	2569	1.9	133.53	45.0	45.0						
	11.5	2346	2.1	121.96	45.0	45.0						
	12.8	2107	2.4	109.54	45.0	45.0						
	13.4	2014	2.5	104.68	45.0	45.0						
	15.0	1791	2.8	93.09	45.0	45.0						
	15.3	1685	2.3	183.27	45.0	45.0	K70390 100L2C / 100L2D	141	102			
	17.2	1499	2.5	162.98	45.0	45.0						
	19.1	1346	2.8	146.38	45.0	45.0						
	6.1	4460	0.8	146.59	30.0	14.6	K60390 132S6A	129	100			
	6.8	4015	0.9	131.96	30.0	14.3						
	7.4	3693	1.0	121.39	30.0	14.1						
	8.3	3295	1.1	108.31	30.0	13.7						
	8.9	3081	1.2	101.29	30.0	13.5						
	9.9	2778	1.3	91.30	30.0	13.2						
	11.1	2470	1.5	81.18	30.0	12.9						
	11.9	2300	1.6	75.60	30.0	12.7						
	12.7	2148	1.6	70.62	30.0	12.5						
14.1	1936	1.8	63.65	30.0	12.1							
14.9	1836	1.8	60.34	30.0	12.0							
16.3	1682	2.0	55.28	30.0	11.7							
17.8	1538	2.2	50.56	30.0	11.5							
19.7	1386	2.3	45.57	30.0	11.1							
21.8	1255	2.3	41.26	30.0	10.8							
25.5	1072	2.7	35.25	30.0	10.1							
28.3	967	3.0	31.77	30.0	9.8							



P ₁ [kW]	n ₂ [Min ⁻¹]	M ₂ [Nm]	f _B	i _{ges}	FR (a) [kN]	FR (b) [kN]	Typ / Type / Tipo / Type / Tipo IE2 / IE3	 ~	 mm				
3.00	8.6	3128	1.1	162.63	30.0	14.8	K60390 100L4C / 100L4D	99	100				
	9.6	2820	1.2	146.59	30.0	14.6							
	10.6	2538	1.4	131.96	30.0	14.3							
	11.5	2335	1.5	121.39	30.0	14.1							
	12.9	2083	1.7	108.31	30.0	13.7							
	13.8	1948	1.8	101.29	30.0	13.5							
	15.3	1756	2.0	91.30	30.0	13.2							
	17.2	1562	2.2	81.18	30.0	12.9							
	18.5	1454	2.4	75.60	30.0	12.7							
	19.8	1358	2.4	70.62	30.0	12.5							
	22.0	1224	2.7	63.65	30.0	12.1							
	23.2	1161	2.8	60.34	30.0	12.0							
	25.3	1063	3.0	55.28	30.0	11.7							
		15.3	1683	1.6	183.08	30.0				15.1	K60390 100L2C / 100L2D	99	100
		17.2	1495	1.8	162.63	30.0				14.8			
		19.1	1348	2.0	146.59	30.0	14.6						
		21.2	1213	2.2	131.96	30.0	14.3						
		23.1	1116	2.4	121.39	30.0	14.1						
		25.9	996	2.7	108.31	30.0	13.7						
		27.6	931	2.9	101.29	30.0	13.5						
		11.0	2482	0.8	81.57	22.0	9.4	K50390 132S6A	102	98			
		11.7	2339	0.8	76.87	22.0	9.2						
		12.7	2155	0.8	70.84	22.0	9.0						
		13.5	2033	0.9	66.83	22.0	8.9						
		14.1	1945	0.9	63.93	22.0	8.8						
		15.8	1733	1.0	56.96	22.0	8.5						
		17.4	1571	1.1	51.63	22.0	8.3						
		18.4	1487	1.2	48.89	22.0	8.2						
		19.3	1417	1.3	46.59	22.0	8.1						
		20.5	1336	1.3	43.91	22.0	7.9						
		22.2	1231	1.5	40.46	22.0	7.8						
		25.5	1074	1.7	35.30	22.0	7.5						
		27.7	990	1.8	32.54	22.0	7.3						
		30.3	903	1.9	29.67	22.0	7.1						
		35.1	780	2.0	25.65	22.0	6.8						
		38.7	708	2.1	23.26	22.0	6.6						
		48.1	569	2.6	18.70	22.0	6.2						
		53.1	516	2.9	16.95	22.0	5.9						
		61.4	446	2.8	14.65	22.0	5.7						
		76.4	358	2.9	11.78	22.0	5.3						
		11.9	2260	0.8	117.49	22.0	10.7	K50390 100L4C / 100L4D	72	98			
		12.5	2153	0.8	111.93	22.0	10.5						
	13.6	1979	0.9	102.86	22.0	9.9							
	15.6	1731	1.0	90.00	22.0	9.6							
	17.2	1569	1.1	81.57	22.0	9.4							
	18.2	1479	1.2	76.87	22.0	9.2							
	19.8	1363	1.2	70.84	22.0	9.0							
	20.9	1286	1.3	66.83	22.0	8.9							
	21.9	1230	1.4	63.93	22.0	8.8							
	24.6	1096	1.6	56.96	22.0	8.5							
	27.1	993	1.7	51.63	22.0	8.3							
	28.6	940	1.8	48.89	22.0	8.2							
	30.0	896	1.9	46.59	22.0	8.1							
	31.9	845	2.0	43.91	22.0	7.9							
	34.6	778	2.2	40.46	22.0	7.8							
	39.7	679	2.5	35.30	22.0	7.5							
	43.0	626	2.7	32.54	22.0	7.3							
	47.2	571	2.8	29.67	22.0	7.1							
	54.6	493	3.0	25.65	22.0	6.8							



P ₁ [kW]	n ₂ [Min ⁻¹]	M ₂ [Nm]	f _B	i _{ges}	FR (a) [kN]	FR (b) [kN]	Typ / Type / Tipo / Type / Tipo IE2 / IE3	 Kg ~	 mm			
3.00	17.4	1482	0.9	161.23	22.0	12.1	K50390 100L2C / 100L2D	72	98			
	19.8	1298	1.1	141.14	22.0	11.1						
	21.6	1192	1.1	129.64	22.0	10.9						
	23.8	1080	1.3	117.49	22.0	10.7						
	25.0	1029	1.3	111.93	22.0	10.5						
	27.2	946	1.4	102.86	22.0	9.9						
	31.1	828	1.7	90.00	22.0	9.6						
	34.3	750	1.8	81.57	22.0	9.4						
	36.4	707	1.8	76.87	22.0	9.2						
	39.5	651	2.0	70.84	22.0	9.0						
	41.9	614	2.1	66.83	22.0	8.9						
	43.8	588	2.2	63.93	22.0	8.8						
	49.2	524	2.5	56.96	22.0	8.5						
	54.2	475	2.7	51.63	22.0	8.3						
	57.3	450	2.9	48.89	22.0	8.2						
60.1	428	3.0	46.59	22.0	8.1							
	23.1	1186	0.8	38.97	18.0	6.0	K40390 132S6A	84	96			
	26.5	1033	0.9	33.95	18.0	5.8						
	28.8	952	0.9	31.29	18.0	5.7						
	31.8	862	1.0	28.33	18.0	5.6						
	34.5	794	1.1	26.11	18.0	5.4						
	40.2	681	1.3	22.40	18.0	5.2						
	50.1	547	1.6	17.98	17.2	4.9						
	55.2	496	1.8	16.29	16.7	4.8						
	63.8	429	2.0	14.11	16.0	4.6						
	79.4	345	2.3	11.33	18.0	4.3						
	87.7	312	2.2	10.26	18.0	4.2						
	104.3	263	2.4	8.63	18.0	3.9						
	115.1	238	2.2	7.82	18.0	3.8						
	23.8	1131	0.8	58.81	18.0	6.9				K40390 100L4C / 100L4D	54	96
	25.7	1047	0.8	54.43	18.0	6.8						
	27.9	965	0.9	50.17	18.0	6.4						
	31.3	861	1.0	44.78	18.0	6.2						
	33.1	813	1.0	42.28	18.0	6.1						
	35.9	750	1.1	38.97	18.0	6.0						
	41.2	653	1.3	33.95	18.0	5.8						
	44.7	602	1.4	31.29	18.0	5.7						
	49.4	545	1.6	28.33	-	5.6						
	53.6	502	1.7	26.11	18.0	5.4						
	62.5	431	2.0	22.40	18.0	5.2						
	77.9	346	2.5	17.98	17.2	4.9						
	85.9	313	2.7	16.29	16.7	4.8						
	99.2	271	3.0	14.11	16.0	4.6						
	30.9	832	0.8	90.52	18.0	8.1	K40390 100L2C / 100L2D	54	96			
	35.3	729	0.9	79.26	18.0	7.8						
	39.0	660	1.0	71.78	18.0	7.6						
	41.3	623	1.0	67.78	18.0	7.2						
	44.8	574	1.1	62.47	18.0	7.0						
	47.6	541	1.2	58.81	18.0	6.9						
	51.2	503	1.3	54.72	18.0	6.8						
	55.8	461	1.4	50.17	18.0	6.4						
	62.5	412	1.6	44.78	18.0	6.2						
	66.2	389	1.7	42.28	18.0	6.1						
	71.9	358	1.8	38.97	18.0	6.0						
	82.5	312	2.1	33.95	18.0	5.8						
	89.5	288	2.2	31.29	18.0	5.7						
	97.1	265	2.4	28.83	18.0	5.6						
	107.2	240	2.7	26.11	18.0	5.4						

P ₁ [kW]	n ₂ [Min ⁻¹]	M ₂ [Nm]	f _B	i _{ges}	FR (a) [kN]	FR (b) [kN]	Typ / Type / Tipo / Type / Tipo IE2 / IE3	 ~	 mm			
3.00	36.0	748	0.8	38.88	12.0	3.8	K35390 100L4C / 100L4D	49	94			
	41.5	648	0.9	33.70	12.0	3.5						
	49.6	543	1.1	28.25	11.8	3.4						
	53.2	506	1.2	26.30	11.6	3.3						
	62.2	433	1.4	22.50	11.2	3.2						
	82.0	329	1.8	17.08	10.5	3.0						
	91.8	293	2.0	15.25	10.2	2.9						
	106.0	254	2.3	13.21	9.9	2.8						
	112.8	239	2.4	12.41	9.7	2.8						
	126.4	213	2.5	11.08	9.4	2.7						
	135.8	198	2.6	10.31	9.2	2.6						
	152.2	177	2.6	9.20	8.9	2.6						
	190.2	142	2.5	7.36	8.4	2.4						
	202.6	133	2.6	6.91	8.3	2.4						
	243.9	110	2.6	5.74	7.8	2.2						
	48.8	528	0.9	57.38	12.0	4.4				K35390 100L2C / 100L2D	49	94
	54.7	471	1.0	51.21	12.0	4.3						
	64.3	401	1.1	43.56	12.0	3.9						
	72.0	357	1.3	38.88	12.0	3.8						
	83.1	310	1.5	33.70	12.0	3.5						
99.1	260	1.8	28.25	12.0	3.4							
106.5	242	1.9	26.30	12.0	3.3							
124.4	207	2.2	22.50	11.0	3.2							
163.9	157	2.9	17.08	11.0	3.0							
4.00	5.5	6611	0.8	162.98	45.0	45.0	K70390 132M6A	171	102			
	6.1	5938	0.9	146.38	45.0	45.0						
	6.7	5416	1.0	133.53	45.0	45.0						
	7.4	4947	1.1	121.96	45.0	45.0						
	8.2	4443	1.2	109.54	45.0	45.0						
	8.6	4246	1.2	104.68	45.0	45.0						
	9.7	3776	1.4	93.09	45.0	45.0						
	10.8	3393	1.5	83.66	45.0	45.0						
	11.8	3094	1.7	76.27	45.0	45.0						
	12.9	2826	1.9	69.66	45.0	45.0						
	14.2	2570	2.0	63.37	45.0	45.0						
	15.4	2366	2.2	58.32	45.0	44.1						
	16.7	2190	2.4	53.98	45.0	43.2						
	17.3	2106	2.5	51.92	45.0	42.9						
	18.8	1938	2.7	47.78	45.0	40.3						
	20.6	1770	2.8	43.64	45.0	39.4						
	7.6	4701	1.1	183.27	45.0	45.0				K70390 112M4C / 112M4D	149	102
	8.6	4180	1.2	162.98	45.0	45.0						
	9.6	3754	1.3	146.38	45.0	45.0						
	10.5	3425	1.5	133.53	45.0	45.0						
	11.5	3128	1.6	121.96	45.0	45.0						
	12.8	2810	1.8	109.54	45.0	45.0						
	13.4	2685	1.9	104.68	45.0	45.0						
	15.0	2388	2.1	93.09	45.0	45.0						
	16.7	2146	2.3	83.66	45.0	45.0						
	18.4	1956	2.6	76.27	45.0	45.0						
	20.1	1787	2.8	69.66	45.0	45.0						
	15.3	2247	1.7	183.27	45.0	45.0						
	17.2	1998	1.9	162.98	45.0	45.0						
	19.1	1795	2.1	146.38	45.0	45.0						
21.0	1637	2.3	133.53	45.0	45.0							
23.0	1495	2.5	121.96	45.0	45.0							
25.6	1343	2.8	109.54	45.0	45.0							
26.7	1283	3.0	104.68	45.0	45.0							



P ₁ [kW]	n ₂ [Min ⁻¹]	M ₂ [Nm]	f _B	i _{ges}	FR (a) [kN]	FR (b) [kN]	Typ / Type / Tipo / Type / Tipo IE2 / IE3	~ Kg	 mm	
4.00	8.3	4393	0.8	108.31	30.0	12.9	K60390 132M6A	129	100	
	8.9	4109	0.9	101.29	30.0	12.7				
	9.9	3703	1.0	91.30	30.0	12.5				
	11.1	3293	1.1	81.18	30.0	12.2				
	11.9	3067	1.2	75.60	30.0	12.1				
	12.7	2865	1.2	70.62	30.0	11.9				
	14.1	2582	1.3	63.65	30.0	11.6				
	14.9	2448	1.4	60.34	30.0	11.5				
	16.3	2242	1.5	55.28	30.0	11.3				
	17.8	2051	1.6	50.56	30.0	11.1				
	19.7	1848	1.7	45.57	30.0	10.8				
	21.8	1674	1.8	41.26	30.0	10.5				
	25.5	1430	2.1	35.25	30.0	10.1				
	28.3	1289	2.3	31.77	30.0	9.8				
	28.7	1273	2.3	31.39	30.0	9.4				
	32.0	1140	2.6	28.11	30.0	9.2				
	34.2	1067	2.8	26.31	30.0	9.0				
	47.6	767	3.0	18.92	30.0	8.3				
		8.6	4171	0.8	162.63	30.0	14.8	K60390 112M4C / 112M4D	107	100
		9.6	3760	0.9	146.59	30.0	13.4			
		10.6	3385	1.0	131.96	30.0	13.2			
		11.5	3113	1.1	121.39	30.0	13.1			
		12.9	2778	1.3	108.31	30.0	12.9			
		13.8	2598	1.3	101.29	30.0	12.7			
		15.3	2342	1.5	91.30	30.0	12.5			
		17.2	2082	1.7	81.18	30.0	12.2			
		18.5	1939	1.8	75.60	30.0	12.1			
		19.8	1811	1.8	70.62	30.0	11.9			
		22.0	1633	2.0	63.65	30.0	11.6			
		23.2	1548	2.1	60.34	30.0	11.5			
		25.3	1418	2.3	55.28	30.0	11.3			
		27.7	1297	2.5	50.56	30.0	11.1			
		30.7	1169	2.6	45.57	30.0	10.8			
		33.9	1058	2.6	41.26	30.0	10.5			
		15.3	2245	1.2	183.08	30.0	15.1	K60390 112M2B / 112M2C	107	100
		17.2	1994	1.3	162.63	30.0	14.8			
		19.1	1797	1.5	146.59	30.0	13.4			
		21.2	1618	1.6	131.96	30.0	13.2			
		23.1	1488	1.8	121.39	30.0	13.1			
		25.9	1328	2.0	108.31	30.0	12.9			
		27.6	1242	2.1	101.29	30.0	12.7			
		30.7	1119	2.4	91.30	30.0	12.5			
	34.5	995	2.7	81.18	30.0	12.2				
	37.0	927	2.9	75.60	30.0	12.1				
	39.6	866	2.9	70.62	30.0	11.9				
	15.8	2310	0.8	56.96	22.0	8.2	K50390 132M6A			
	17.4	2094	0.9	51.63	22.0	8.1				
	18.4	1983	0.9	48.89	22.0	7.9				
	19.3	1890	0.9	46.59	22.0	7.8				
	20.5	1781	1.0	43.91	22.0	7.7				
	22.2	1641	1.1	40.46	22.0	7.6				
	25.5	1432	1.2	35.30	22.0	7.3				
	27.7	1320	1.4	32.54	22.0	7.1				
	30.3	1204	1.4	29.67	22.0	7.0				
	35.1	1040	1.5	25.65	22.0	6.7				
	38.7	943	1.6	23.26	22.0	6.5				
	48.1	759	1.9	18.70	21.4	6.1				
	53.1	688	2.1	16.95	22.0	5.9				
	61.4	594	2.1	14.65	22.0	5.7				
	76.4	478	2.2	11.78	22.0	5.3				
	84.3	433	2.4	10.68	22.0	5.2				
	100.2	364	2.6	8.98	22.0	4.8				
	110.7	330	2.5	8.13	22.0	4.7				



P ₁ [kW]	n ₂ [Min ⁻¹]	M ₂ [Nm]	f _B	i _{ges}	FR (a) [kN]	FR (b) [kN]	Typ / Type / Tipo / Type / Tipo IE2 / IE3	 ~			
4.00	15.6	2308	0.8	90.00	22.0	9.6	K50390 112M4C / 112M4D	80	98		
	17.2	2092	0.9	81.57	22.0	9.4					
	18.2	1972	0.9	76.87	22.0	9.2					
	19.8	1817	0.9	70.84	22.0	8.7					
	20.9	1714	1.0	66.83	22.0	8.6					
	21.9	1640	1.0	63.93	22.0	8.5					
	24.6	1461	1.2	56.96	22.0	8.2					
	27.1	1324	1.3	51.63	22.0	8.1					
	28.6	1254	1.4	48.89	22.0	7.9					
	30.0	1195	1.4	46.59	22.0	7.8					
	31.9	1126	1.5	43.91	22.0	7.7					
	34.6	1038	1.6	40.46	22.0	7.6					
	39.7	905	1.9	35.30	22.0	7.3					
	43.0	835	2.0	32.54	22.0	7.1					
	47.2	761	2.1	29.67	22.0	7.0					
	54.6	658	2.3	25.65	22.0	6.7					
	60.2	597	2.3	23.26	22.0	6.5					
	74.9	480	2.9	18.70	21.4	6.1					
	19.8	1730	0.8	141.14	22.0	11.1	K50390 112M2B / 112M2C	80	98		
	21.6	1589	0.9	129.64	22.0	10.9					
	23.8	1440	0.9	117.49	22.0	10.7					
	25.0	1372	1.0	111.93	22.0	10.5					
	27.2	1261	1.1	102.86	22.0	9.9					
	31.1	1103	1.2	90.00	22.0	9.6					
	34.3	1000	1.4	81.57	22.0	9.4					
	36.4	942	1.4	76.87	22.0	9.2					
	39.5	868	1.5	70.84	22.0	8.7					
	41.9	819	1.6	66.83	22.0	8.6					
	43.8	784	1.6	63.93	22.0	8.5					
	49.2	698	1.9	56.96	22.0	8.2					
	54.2	633	2.0	51.63	22.0	8.1					
	57.3	599	2.2	48.89	22.0	7.9					
	60.1	571	2.3	46.59	22.0	7.8					
	63.8	538	2.4	43.91	22.0	7.7					
	69.2	496	2.6	40.46	22.0	7.6					
	79.3	433	3.0	35.30	22.0	7.3					
	31.8	1149	0.8	28.33	18.0	5.4	K40390 132M6A	84	96		
	34.5	1059	0.8	26.11	18.0	5.2					
	40.2	909	1.0	22.40	17.7	5.0					
	50.1	729	1.2	17.98	16.7	4.8					
	55.2	661	1.4	16.29	16.3	4.7					
	63.8	572	1.5	14.11	15.7	4.5					
	79.4	460	1.7	11.33	14.8	4.2					
87.7	416	1.6	10.26	14.3	4.1						
104.3	350	1.8	8.63	13.6	3.9						
115.1	317	1.7	7.82	13.2	3.8						
33.1	1084	0.8	42.28	18.0	6.1	K40390 112M4C / 112M4D				62	96
35.9	1000	0.9	38.97	18.0	6.0						
41.2	871	1.0	33.95	18.0	5.6						
44.7	803	1.1	31.29	18.0	5.5						
49.4	727	1.2	28.33	-	5.4						
53.6	670	1.3	26.11	18.0	5.2						
62.5	575	1.5	22.40	17.7	5.0						
77.9	461	1.8	17.98	16.7	4.8						
85.9	418	2.0	16.29	16.3	4.7						
99.2	362	2.2	14.11	15.7	4.5						
123.6	291	2.6	11.33	14.8	4.2						
136.5	263	2.5	10.26	14.3	4.1						
162.2	221	2.7	8.63	13.6	3.9						
179.0	201	2.5	7.82	13.2	3.8						



P ₁ [kW]	n ₂ [Min ⁻¹]	M ₂ [Nm]	f _B	i _{ges}	FR (a) [kN]	FR (b) [kN]	Typ / Type / Tipo / Type / Tipo IE2 / IE3	 Kg ~	 mm				
4.00	41.3	831	0.8	67.78	18.0	7.2	K40390 112M2B / 112M2C	62	96				
	44.8	766	0.8	62.47	18.0	7.0							
	47.6	721	0.9	58.81	18.0	6.9							
	51.2	671	1.0	54.72	18.0	6.8							
	55.8	615	1.1	50.17	18.0	6.4							
	62.5	549	1.2	44.78	18.0	6.2							
	66.2	518	1.2	42.28	18.0	6.1							
	71.9	478	1.4	38.97	18.0	6.0							
	82.5	416	1.6	33.95	18.0	5.6							
	89.5	384	1.7	31.29	18.0	5.5							
	97.1	353	1.8	28.83	18.0	5.4							
	107.2	320	2.0	26.11	18.0	5.2							
	125.0	275	2.4	22.40	18.0	5.0							
	155.7	220	2.9	17.98	17.0	4.8							
		49.6	725	0.8	28.25	11.8				3.4	K35390 112M4C / 112M4D	57	94
		53.2	675	0.9	26.30	10.9	3.1						
		62.2	577	1.0	22.50	10.6	3.0						
		82.0	438	1.4	17.08	10.0	2.9						
		91.8	391	1.5	15.25	9.8	2.8						
		106.0	339	1.7	13.21	9.5	2.7						
		112.8	318	1.8	12.41	9.4	2.7						
		126.4	284	1.9	11.08	9.1	2.6						
		135.8	264	2.0	10.31	8.9	2.6						
		152.2	236	1.9	9.20	8.7	2.5						
		190.2	189	1.9	7.36	8.2	2.3						
		202.6	177	1.9	6.91	8.1	2.3						
		243.9	147	2.0	5.74	7.7	2.2						
		64.3	534	0.9	43.56	11.8	3.9	K35390 112M2B / 112M2C	57	94			
		72.0	477	1.0	38.88	11.8	3.8						
		83.1	413	1.1	33.70	11.8	3.5						
	99.1	346	1.3	28.25	11.8	3.4							
	106.5	322	1.4	26.30	10.9	3.1							
	124.4	276	1.7	22.50	10.6	3.0							
	163.9	209	2.2	17.08	10.0	2.9							
	183.6	187	2.4	15.25	9.8	2.8							
	212.0	162	2.8	13.21	9.5	2.7							
	225.6	152	2.9	12.41	9.4	2.7							
	252.7	136	3.0	11.08	9.1	2.6							
	380.4	90	2.9	7.36	8.2	2.3							
5.50	5.3	9401	0.9	168.56	65.0	65.0	K90390 132M6B				273	104	
	6.0	8427	1.0	151.10	65.0	65.0							
	6.6	7634	1.1	136.87	65.0	65.0							
	7.1	7040	1.2	126.23	65.0	65.0							
	8.6	5866	1.4	105.17	65.0	65.0							
	9.5	5293	1.6	94.90	65.0	65.0							
	10.1	4957	1.7	88.87	65.0	65.0							
	10.5	4771	1.8	85.54	65.0	65.0							
	11.4	4393	1.9	78.76	65.0	65.0							
	12.5	4025	2.1	72.16	65.0	65.0							
	13.9	3616	2.3	64.83	65.0	65.0							
	14.5	3470	2.4	62.21	65.0	65.0							
	15.4	3263	2.6	58.50	65.0	65.0							
	16.2	3093	2.7	55.45	65.0	65.0							
	17.4	2880	2.9	51.63	65.0	65.0							
		8.3	5945	1.3	168.56	65.0	65.0	K90390 132S4A / 132S4B	273	104			
		9.3	5329	1.5	151.10	-	65.0						
		10.2	4827	1.7	136.87	65.0	65.0						
		11.1	4452	1.8	126.23	65.0	65.0						
		13.3	3709	2.2	105.17	65.0	65.0						
		14.8	3347	2.4	94.90	65.0	65.0						
		15.8	3134	2.6	88.87	65.0	65.0						
		16.4	3017	2.7	85.54	65.0	65.0						
		17.8	2778	2.9	78.76	65.0	65.0						
		16.6	2841	2.1	168.56	65.0	65.0				K90390 132S2B / 132S2C	273	104
		18.5	2547	2.4	151.10	65.0	65.0						
		20.5	2307	2.6	136.87	65.0	65.0						
		22.2	2128	2.9	126.23	65.0	65.0						



P ₁ [kW]	n ₂ [Min ⁻¹]	M ₂ [Nm]	f _B	i _{ges}	FR (a) [kN]	FR (b) [kN]	Typ / Type / Tipo / Type / Tipo IE2 / IE3	 ~		
5.50	7.4	6802	0.8	121.96	45.0	45.0	K70390 132M6B	171	102	
	8.2	6109	0.9	109.54	45.0	45.0				
	8.6	5838	0.9	104.68	45.0	45.0				
	9.7	5192	1.0	93.09	45.0	45.0				
	10.8	4666	1.1	83.66	45.0	45.0				
	11.8	4254	1.2	76.27	44.5	44.5				
	12.9	3885	1.4	69.66	43.7	43.7				
	14.2	3534	1.5	63.37	42.1	43.0				
	15.4	3253	1.6	58.32	42.1	42.1				
	16.7	3011	1.7	53.98	41.4	41.4				
	17.3	2896	1.8	51.92	41.2	41.2				
	18.8	2665	2.0	47.78	40.3	40.3				
	20.6	2434	2.1	43.64	45.0	39.4				
	22.9	2190	2.3	39.27	45.0	38.5				
	24.9	2019	2.5	36.20	45.0	37.6				
	28.0	1795	2.7	32.18	45.0	35.2				
	30.3	1654	3.0	29.66	45.0	34.4				
		7.6	6463	0.8	183.27	45.0	45.0	K70390 132S4A / 132S4B	171	102
		8.6	5748	0.9	162.98	45.0	45.0			
		9.6	5162	1.0	146.38	45.0	45.0			
		10.5	4709	1.1	133.53	45.0	45.0			
		11.5	4301	1.2	121.96	45.0	45.0			
		12.8	3863	1.3	109.54	45.0	45.0			
		13.4	3692	1.4	104.68	45.0	45.0			
		15.0	3283	1.5	93.09	45.0	45.0			
		16.7	2950	1.7	83.66	45.0	45.0			
		18.4	2690	1.9	76.27	44.5	44.5			
		20.1	2457	2.0	69.66	43.7	43.7			
		22.1	2235	2.2	63.37	42.1	43.0			
		24.0	2057	2.4	58.32	42.1	42.1			
		25.9	1904	2.6	53.98	41.4	41.4			
		27.0	1831	2.7	51.92	41.2	41.2			
		29.3	1685	3.0	47.78	40.3	40.3			
	15.3	3089	1.2	183.27	45.0	45.0	K70390 132S2B / 132S2C	171	102	
	17.2	2747	1.4	162.98	45.0	45.0				
	19.1	2468	1.5	146.38	45.0	45.0				
	21.0	2251	1.7	133.53	45.0	45.0				
	23.0	2056	1.8	121.96	45.0	45.0				
	25.6	1847	2.1	109.54	45.0	45.0				
	26.7	1765	2.2	104.68	45.0	45.0				
	30.1	1569	2.4	93.09	45.0	45.0				
	33.5	1410	2.7	83.66	45.0	45.0				
	36.7	1286	3.0	76.27	44.5	44.5				
	11.1	4528	0.8	81.18	30.0	11.3	K60390 132M6B	129	100	
	11.9	4217	0.9	75.60	30.0	11.2				
	12.7	3939	0.9	70.62	30.0	11.1				
	14.1	3550	1.0	63.65	30.0	10.9				
	14.9	3365	1.0	60.34	30.0	10.8				
	16.3	3083	1.1	55.28	30.0	10.6				
	17.8	2820	1.2	50.56	30.0	10.4				
	19.7	2542	1.2	45.57	30.0	10.2				
	21.8	2301	1.3	41.26	30.0	10.0				
	25.5	1966	1.5	35.25	30.0	9.7				
	28.3	1772	1.7	31.77	30.0	9.5				
	28.7	1751	1.7	31.39	30.0	9.4				
	32.0	1568	1.9	28.11	30.0	9.2				
	34.2	1467	2.0	26.31	30.0	9.0				
	38.7	1298	2.3	23.27	30.0	8.7				
	42.9	1171	2.2	21.00	30.0	8.5				
	47.6	1055	2.2	18.92	30.0	8.3				
	57.4	874	2.5	15.67	30.0	7.6				
	63.6	789	2.8	14.15	30.0	7.4				
	70.6	711	3.0	12.75	30.0	7.2				



P ₁ [kW]	n ₂ [Min ⁻¹]	M ₂ [Nm]	f _B	i _{ges}	FR (a) [kN]	FR (b) [kN]	Typ / Type / Tipo / Type / Tipo IE2 / IE3	~ Kg	 mm			
5.50	10.6	4654	0.8	131.96	30.0	13.2	K60390 132S4A / 132S4B	129	100			
	11.5	4281	0.8	121.39	30.0	11.6						
	12.9	3820	0.9	108.31	30.0	11.6						
	13.8	3572	1.0	101.29	30.0	11.5						
	15.3	3220	1.1	91.30	30.0	11.4						
	17.2	2863	1.2	81.18	30.0	11.3						
	18.5	2666	1.3	75.60	30.0	11.2						
	19.8	2491	1.3	70.62	30.0	11.1						
	22.0	2245	1.5	63.65	30.0	10.9						
	23.2	2128	1.5	60.34	30.0	10.8						
	25.3	1950	1.6	55.28	30.0	10.6						
	27.7	1783	1.8	50.56	30.0	10.4						
	30.7	1607	1.9	45.57	30.0	10.2						
	33.9	1455	1.9	41.26	30.0	10.0						
	39.7	1243	2.3	35.25	30.0	9.7						
	44.1	1120	2.5	31.77	30.0	9.5						
	44.6	1107	2.5	31.39	30.0	9.4						
	49.8	991	2.8	28.11	30.0	9.2						
	53.2	928	3.0	26.31	30.0	9.0						
	15.3	3086	0.9	183.08	30.0	15.1				K60390 132S2B / 132S2C	129	100
	17.2	2742	1.0	162.63	30.0	14.8						
	19.1	2471	1.1	146.59	30.0	13.4						
	21.2	2224	1.2	131.96	30.0	13.2						
	23.1	2046	1.3	121.39	30.0	13.1						
	25.9	1826	1.5	108.31	30.0	11.6						
	27.6	1707	1.6	101.29	30.0	11.5						
	30.7	1539	1.7	91.30	30.0	11.4						
	34.5	1368	1.9	81.18	30.0	11.3						
	37.0	1274	2.1	75.60	30.0	11.2						
	39.6	1190	2.1	70.62	30.0	11.1						
	44.0	1073	2.3	63.65	30.0	10.9						
	46.4	1017	2.4	60.34	30.0	10.8						
	50.7	932	2.6	55.28	30.0	10.6						
	55.4	852	2.9	50.56	30.0	10.4						
	61.4	768	3.0	45.57	30.0	10.2						
22.2	2257	0.8	40.46	22.0	7.2	K50390 132M6B	102	98				
25.5	1969	0.9	35.30	22.0	7.0							
27.7	1815	1.0	32.54	22.0	6.9							
30.3	1655	1.0	29.67	22.0	6.7							
35.1	1431	1.1	25.65	22.0	6.5							
38.7	1297	1.1	23.26	22.0	6.3							
48.1	1043	1.4	18.70	20.9	6.0							
53.1	945	1.6	16.95	20.3	5.8							
61.4	817	1.5	14.65	19.5	5.6							
76.4	657	1.6	11.78	18.3	5.2							
84.3	596	1.8	10.68	17.8	5.1							
100.2	501	1.9	8.98	16.8	4.8							
110.7	453	1.9	8.13	16.3	4.7							
21.9	2255	0.8	63.93	22.0	8.5				K50390 132S4A / 132S4B	102	98	
24.6	2009	0.8	56.96	22.0	8.2							
27.1	1821	0.9	51.63	22.0	7.7							
28.6	1724	1.0	48.89	22.0	7.6							
30.0	1643	1.0	46.59	22.0	7.5							
31.9	1549	1.1	43.91	22.0	7.4							
34.6	1427	1.2	40.46	22.0	7.2							
39.7	1245	1.4	35.30	22.0	7.0							
43.0	1148	1.5	32.54	22.0	6.9							
47.2	1046	1.5	29.67	22.0	6.7							
54.6	905	1.7	25.65	22.0	6.5							
60.2	820	1.7	23.26	22.0	6.3							
74.9	659	2.1	18.70	20.9	6.0							
82.6	598	2.3	16.95	20.3	5.8							
95.6	517	2.3	14.65	19.5	5.6							
118.8	415	2.4	11.78	18.3	5.2							
131.1	377	2.7	10.68	17.8	5.1							
155.9	317	2.8	8.98	16.8	4.8							
172.2	287	2.8	8.13	16.3	4.7							



P ₁ [kW]	n ₂ [Min ⁻¹]	M ₂ [Nm]	f _B	i _{ges}	FR (a) [kN]	FR (b) [kN]	Typ / Type / Tipo / Type / Tipo IE2 / IE3	 ~	 mm
5.50	31.1	1517	0.9	90.00	22.0	9.6	K50390 132S2B / 132S2C	102	98
	34.3	1375	1.0	81.57	22.0	9.4			
	36.4	1296	1.0	76.87	22.0	9.2			
	39.5	1194	1.1	70.84	22.0	8.7			
	41.9	1127	1.1	66.83	22.0	8.6			
	43.8	1078	1.2	63.93	22.0	8.5			
	49.2	960	1.3	56.96	22.0	8.2			
	54.2	870	1.5	51.63	22.0	7.7			
	57.3	824	1.6	48.89	22.0	7.6			
	60.1	785	1.6	46.59	22.0	7.5			
	63.8	740	1.7	43.91	22.0	7.4			
	69.2	682	1.9	40.46	22.0	7.2			
	79.3	595	2.2	35.30	22.0	7.0			
	86.0	549	2.4	32.54	22.0	6.9			
	94.4	500	2.4	29.67	22.0	6.7			
	109.2	432	2.6	25.65	22.0	6.5			
	120.4	392	2.7	23.26	22.0	6.3			
	50.1	1003	0.9	17.98	16.0	4.6			
	55.2	909	1.0	16.29	15.7	4.5			
	63.8	787	1.1	14.11	15.1	4.3			
	79.4	632	1.2	11.33	14.3	4.1			
	87.7	572	1.2	10.26	14.0	4.0			
	104.3	481	1.3	8.63	13.2	3.8			
	115.1	436	1.2	7.82	12.9	3.7			
	44.7	1103	0.8	31.29	18.0	5.5	K40390 132S4A / 132S4B	84	96
	49.4	999	0.9	28.33	-	5.4			
	53.6	921	0.9	26.11	17.4	5.0			
	62.5	790	1.1	22.40	16.8	4.8			
	77.9	634	1.3	17.98	16.0	4.6			
	85.9	574	1.5	16.29	15.7	4.5			
	99.2	498	1.6	14.11	15.1	4.3			
	123.6	400	1.9	11.33	14.3	4.1			
	136.5	362	1.8	10.26	14.0	4.0			
	162.2	304	2.0	8.63	13.2	3.8			
	179.0	276	1.8	7.82	12.9	3.7			
	55.8	846	0.8	50.17	18.0	6.4			
	62.5	755	0.9	44.78	18.0	6.2			
	66.2	713	0.9	42.28	18.0	6.1			
	71.9	657	1.0	38.97	18.0	6.0			
	82.5	572	1.1	33.95	18.0	5.6			
	89.5	527	1.2	31.29	18.0	5.5			
	97.1	486	1.3	28.83	17.4	5.4			
	107.2	440	1.5	26.11	17.4	5.0			
	125.0	378	1.7	22.40	16.8	4.8			
	155.7	303	2.1	17.98	16.0	4.6			
	171.9	275	2.4	16.29	15.7	4.5			
	198.4	238	2.6	14.11	15.1	4.3			
	247.1	191	3.0	11.33	14.3	4.1			
272.9	173	2.9	10.26	14.0	4.0				
358.1	132	2.9	7.82	12.9	3.7				
7.50	6.6	10410	0.8	136.87	65.0	65.0	K90390 160M6B / 160M6C	317	104
	7.1	9600	0.9	126.23	65.0	65.0			
	8.6	7999	1.1	105.17	65.0	65.0			
	9.5	7218	1.2	94.90	65.0	65.0			
	10.1	6759	1.2	88.87	65.0	65.0			
	10.5	6506	1.3	85.54	65.0	65.0			
	11.4	5990	1.4	78.76	65.0	65.0			
	12.5	5488	1.5	72.16	65.0	65.0			
	13.9	4931	1.7	64.83	65.0	65.0			
	14.5	4731	1.8	62.21	65.0	65.0			
	15.4	4449	1.9	58.50	64.8	64.8			
	16.2	4217	2.0	55.45	63.9	63.9			
	17.4	3927	2.1	51.63	65.0	62.5			
	18.5	3692	2.3	48.55	65.0	61.3			
	21.0	3266	2.6	42.94	65.0	57.9			
	22.6	3022	2.8	39.74	65.0	55.1			



P ₁ [kW]	n ₂ [Min ⁻¹]	M ₂ [Nm]	f _B	i _{ges}	FR (a) [kN]	FR (b) [kN]	Typ / Type / Tipo / Type / Tipo IE2 / IE3	 ~ Kg	 mm			
7.50	8.3	8106	1.0	168.56	65.0	65.0	K90390 132M4C / 132M4D	273	104			
	9.3	7267	1.1	151.10	65.0	65.0						
	10.2	6582	1.2	136.87	-	65.0						
	11.1	6071	1.3	126.23	65.0	65.0						
	13.3	5058	1.6	105.17	65.0	65.0						
	14.8	4564	1.8	94.90	65.0	65.0						
	15.8	4274	1.9	88.87	65.0	65.0						
	16.4	4114	1.9	85.54	65.0	65.0						
	17.8	3788	2.1	78.76	65.0	65.0						
	19.4	3470	2.3	72.16	65.0	65.0						
	21.6	3118	2.6	64.83	65.0	65.0						
	22.5	2992	2.7	62.21	65.0	65.0						
	23.9	2813	2.8	58.50	64.8	64.8						
	25.2	2667	3.0	55.45	63.9	63.9						
	16.6	3875	1.6	168.56	65.0	65.0				K90390 132S2C / 132S2D	273	104
	18.5	3473	1.8	151.10	65.0	65.0						
	20.5	3146	1.9	136.87	65.0	65.0						
	22.2	2902	2.1	126.23	65.0	65.0						
	26.6	2418	2.5	105.17	65.0	65.0						
	31.5	2043	3.0	88.87	65.0	65.0						
	10.8	6363	0.8	83.66	41.6	41.6	K70390 160M6B / 160M6C	207	102			
	11.8	5801	0.9	76.27	41.1	41.1						
	12.9	5298	1.0	69.66	40.6	40.6						
	14.2	4820	1.1	63.37	40.1	40.1						
	15.4	4436	1.2	58.32	39.5	39.5						
	16.7	4105	1.3	53.98	39.0	39.0						
	17.3	3949	1.3	51.92	38.8	38.8						
	18.8	3634	1.4	47.78	38.1	38.1						
	20.6	3319	1.5	43.64	37.4	37.4						
	22.9	2987	1.7	39.27	36.7	36.7						
	24.9	2753	1.8	36.20	36.0	36.0						
	28.0	2447	2.0	32.18	35.2	35.2						
	30.3	2256	2.2	29.66	45.0	34.4						
	33.2	2060	2.3	27.09	45.0	33.6						
	36.1	1894	2.6	24.90	45.0	33.1						
	40.1	1706	2.7	22.43	45.0	30.4						
	44.1	1552	2.7	20.40	45.0	29.8						
	49.0	1398	2.7	18.38	45.0	29.1						
	53.6	1277	2.6	16.79	45.0	28.4						
	63.2	1082	3.0	14.23	45.0	27.3						
	10.5	6422	0.8	133.53	45.0	45.0	K70390 132M4C / 132M4D	171	102			
	11.5	5865	0.9	121.96	45.0	45.0						
	12.8	5268	0.9	109.54	42.5	42.5						
	13.4	5034	1.0	104.68	42.4	42.4						
	15.0	4477	1.1	93.09	42.0	42.0						
	16.7	4023	1.2	83.66	41.6	41.6						
	18.4	3668	1.4	76.27	41.1	41.1						
	20.1	3350	1.5	69.66	40.6	40.6						
22.1	3048	1.6	63.37	40.1	40.1							
24.0	2805	1.8	58.32	39.5	39.5							
25.9	2596	1.9	53.98	39.0	39.0							
27.0	2497	2.0	51.92	38.8	38.8							
29.3	2298	2.2	47.78	38.1	38.1							
32.1	2099	2.3	43.64	37.4	37.4							
35.7	1889	2.5	39.27	36.7	36.7							
38.7	1741	2.8	36.20	36.0	36.0							
43.5	1548	3.0	32.18	35.2	35.2							
15.3	4213	0.9	183.27	45.0	45.0	K70390 132S2C / 132S2D				171	102	
17.2	3746	1.0	162.98	45.0	45.0							
19.1	3365	1.1	146.38	45.0	45.0							
21.0	3069	1.2	133.53	45.0	45.0							
23.0	2804	1.4	121.96	45.0	45.0							
25.6	2518	1.5	109.54	42.5	42.5							
26.7	2406	1.6	104.68	42.4	42.4							
30.1	2140	1.8	93.09	42.0	42.0							
33.5	1923	2.0	83.66	41.6	41.6							
36.7	1753	2.2	76.27	41.1	41.1							
40.2	1601	2.4	69.66	40.6	40.6							
44.2	1457	2.6	63.37	40.1	40.1							
48.0	1341	2.8	58.32	39.5	39.5							

P ₁ [kW]	n ₂ [Min ⁻¹]	M ₂ [Nm]	f _B	i _{ges}	FR (a) [kN]	FR (b) [kN]	Typ / Type / Tipo / Type / Tipo IE2 / IE3	 ~	
7.50	16.3	4204	0.8	55.28	30.0	9.7	K60390 160M6B / 160M6C	165	100
	17.8	3845	0.9	50.56	30.0	9.6			
	19.7	3466	0.9	45.57	30.0	9.5			
	21.8	3138	0.9	41.26	30.0	9.4			
	25.5	2681	1.1	35.25	30.0	9.1			
	28.3	2416	1.2	31.77	30.0	8.9			
	28.7	2387	1.2	31.39	30.0	8.9			
	32.0	2138	1.4	28.11	30.0	8.7			
	34.2	2001	1.5	26.31	30.0	8.6			
	38.7	1770	1.7	23.27	29.3	8.4			
	42.9	1597	1.6	21.00	28.6	8.2			
	47.6	1439	1.6	18.92	28.0	8.0			
	57.4	1192	1.9	15.67	26.7	7.6			
	63.6	1076	2.0	14.15	30.0	7.4			
	70.6	970	2.2	12.75	30.0	7.2			
	85.2	803	2.6	10.56	30.0	6.6			
	93.5	732	2.6	9.63	30.0	6.5			
	112.9	606	2.6	7.97	30.0	6.2			
	15.3	4391	0.8	91.30	30.0	11.4	K60390 132M4C / 132M4D	129	100
	17.2	3904	0.9	81.18	30.0	10.0			
	18.5	3636	1.0	75.60	30.0	10.0			
	19.8	3396	1.0	70.62	30.0	9.9			
	22.0	3061	1.1	63.65	30.0	9.9			
	23.2	2902	1.1	60.34	30.0	9.8			
	25.3	2658	1.2	55.28	30.0	9.7			
	27.7	2431	1.3	50.56	30.0	9.6			
	30.7	2192	1.4	45.57	30.0	9.5			
	33.9	1984	1.4	41.26	30.0	9.4			
	39.7	1695	1.7	35.25	30.0	9.1			
	44.1	1528	1.8	31.77	30.0	8.9			
	44.6	1510	1.9	31.39	30.0	8.9			
	49.8	1352	2.1	28.11	30.0	8.7			
	53.2	1265	2.2	26.31	30.0	8.6			
	60.2	1119	2.5	23.27	29.3	8.4			
	66.7	1010	2.5	21.00	28.6	8.2			
	74.0	910	2.4	18.92	28.0	8.0			
	89.3	754	2.8	15.67	26.7	7.6			
	19.1	3370	0.8	146.59	30.0	13.4	K60390 132S2C / 132S2D	129	100
	21.2	3033	0.9	131.96	30.0	13.2			
	23.1	2790	1.0	121.39	30.0	13.1			
	25.9	2490	1.1	108.31	30.0	11.6			
	27.6	2328	1.1	101.29	30.0	11.5			
	30.7	2099	1.3	91.30	30.0	11.4			
	34.5	1866	1.4	81.18	30.0	10.0			
	37.0	1738	1.5	75.60	30.0	10.0			
39.6	1623	1.5	70.62	30.0	9.9				
44.0	1463	1.7	63.65	30.0	9.9				
46.4	1387	1.8	60.34	30.0	9.8				
50.7	1271	1.9	55.28	30.0	9.7				
55.4	1162	2.1	50.56	30.0	9.6				
61.4	1048	2.2	45.57	30.0	9.5				
67.9	948	2.2	41.26	30.0	9.4				
79.4	810	2.6	35.25	30.0	9.1				
88.1	730	2.9	31.77	30.0	8.9				
89.2	722	2.9	31.39	30.0	8.9				
35.1	1951	0.8	25.65	21.8	6.2	K50390 160M6B / 160M6C	138	98	
38.7	1769	0.8	23.26	21.3	6.1				
48.1	1422	1.0	18.70	20.2	5.8				
53.1	1289	1.1	16.95	19.7	5.6				
61.4	1114	1.1	14.65	19.0	5.4				
76.4	896	1.2	11.78	17.9	5.1				
84.3	812	1.3	10.68	17.4	5.0				
100.2	683	1.4	8.98	16.5	4.7				
110.7	618	1.4	8.13	16.0	4.6				



P ₁ [kW]	n ₂ [Min ⁻¹]	M ₂ [Nm]	f _B	i _{ges}	FR (a) [kN]	FR (b) [kN]	Typ / Type / Tipo / Type / Tipo IE2 / IE3	 ~	
7.50	30.0	2241	0.8	46.59	22.0	7.5	K50390 132M4C / 132M4D	102	98
	31.9	2112	0.8	43.91	22.0	7.4			
	34.6	1946	0.9	40.46	22.0	7.2			
	39.7	1698	1.0	35.30	22.0	6.7			
	43.0	1565	1.1	32.54	22.0	6.5			
	47.2	1427	1.1	29.67	22.0	6.4			
	54.6	1234	1.2	25.65	21.8	6.2			
	60.2	1119	1.3	23.26	21.3	6.1			
	74.9	899	1.6	18.70	20.2	5.8			
	82.6	815	1.7	16.95	19.7	5.6			
	95.6	705	1.7	14.65	19.0	5.4			
	118.8	567	1.8	11.78	17.9	5.1			
	131.1	514	1.9	10.68	17.4	5.0			
	155.9	432	2.1	8.98	16.5	4.7			
	172.2	391	2.0	8.13	16.0	4.6			
	39.5	1628	0.8	70.84	22.0	8.7	K50390 132S2C / 132S2D	102	98
	41.9	1536	0.8	66.83	22.0	8.6			
	43.8	1470	0.9	63.93	22.0	8.5			
	49.2	1309	1.0	56.96	22.0	8.2			
	54.2	1187	1.1	51.63	22.0	7.7			
	57.3	1124	1.1	48.89	22.0	7.6			
	60.1	1071	1.2	46.59	22.0	7.5			
	63.8	1009	1.3	43.91	22.0	7.4			
	69.2	930	1.4	40.46	22.0	7.2			
	79.3	811	1.6	35.30	22.0	6.7			
	86.0	748	1.7	32.54	22.0	6.5			
	94.4	682	1.8	29.67	22.0	6.4			
	109.2	590	1.9	25.65	21.8	6.2			
	120.4	535	2.0	23.26	21.3	6.1			
	149.7	430	2.5	18.70	20.2	5.8			
165.2	390	2.7	16.95	19.7	5.6				
191.1	337	2.7	14.65	19.0	5.4				
237.7	271	2.8	11.78	17.9	5.1				
62.5	1077	0.8	22.40	16.8	4.8	K40390 132M4C / 132M4D	84	96	
77.9	865	1.0	17.98	15.1	4.3				
85.9	783	1.1	16.29	14.8	4.2				
99.2	679	1.2	14.11	14.4	4.1				
123.6	545	1.4	11.33	13.7	3.9				
136.5	493	1.3	10.26	13.4	3.8				
162.2	415	1.4	8.63	12.8	3.7				
179.0	376	1.3	7.82	12.5	3.6				
82.5	780	0.8	33.95	16.8	5.6				K40390 132S2C / 132S2D
89.5	719	0.9	31.29	16.8	5.5				
97.1	663	1.0	28.83	16.8	5.4				
107.2	600	1.1	26.11	16.8	5.0				
125.0	515	1.3	22.40	16.8	4.8				
155.7	413	1.6	17.98	15.1	4.3				
171.9	374	1.7	16.29	14.8	4.2				
198.4	324	1.9	14.11	14.4	4.1				
247.1	260	2.2	11.33	13.7	3.9				
272.9	236	2.1	10.26	13.4	3.8				
324.4	198	2.3	8.63	12.8	3.7				
358.1	180	2.1	7.82	12.5	3.6				
9.20	8.6	9812	0.9	105.17	65.0	65.0	K90390 160M6	317	104
	9.5	8854	0.9	94.90	65.0	65.0			
	10.1	8291	1.0	88.87	65.0	65.0			
	10.5	7980	1.1	85.54	65.0	65.0			
	11.4	7348	1.1	78.76	65.0	65.0			
	12.5	6732	1.2	72.16	65.0	65.0			
	13.9	6048	1.4	64.83	65.0	65.0			
	14.5	5804	1.4	62.21	65.0	65.0			
	15.4	5458	1.5	58.50	63.9	63.9			
	16.2	5173	1.6	55.45	63.1	63.1			
	17.4	4817	1.7	51.63	61.7	61.7			
	18.5	4529	1.9	48.55	60.6	60.6			
	21.0	4006	2.1	42.94	65.0	58.6			
	22.6	3708	2.3	39.74	65.0	56.5			
	25.1	3345	2.5	35.85	65.0	54.8			
	26.3	3189	2.6	34.18	65.0	53.0			
	29.2	2877	2.9	30.84	65.0	51.5			
35.2	2388	3.0	25.60	65.0	48.8				



P ₁ [kW]	n ₂ [Min ⁻¹]	M ₂ [Nm]	f _B	i _{ges}	FR (a) [kN]	FR (b) [kN]	Typ / Type / Tipo / Type / Tipo IE2 / IE3	 ~	
9.20	8.3	9944	0.8	168.56	-	65.0	K90390 132M4	273	104
	9.3	8914	0.9	151.10	-	65.0			
	10.2	8074	1.0	136.87	65.0	65.0			
	11.1	7447	1.1	126.23	65.0	65.0			
	13.3	6204	1.3	105.17	65.0	65.0			
	14.8	5598	1.4	94.90	65.0	65.0			
	15.8	5243	1.5	88.87	65.0	65.0			
	16.4	5046	1.6	85.54	65.0	65.0			
	17.8	4646	1.7	78.76	65.0	65.0			
	19.4	4257	1.9	72.16	65.0	65.0			
	21.6	3824	2.1	64.83	65.0	65.0			
	22.5	3670	2.2	62.21	65.0	65.0			
	23.9	3451	2.3	58.50	63.9	63.9			
	25.2	3271	2.4	55.45	63.1	63.1			
	27.1	3046	2.6	51.63	61.7	61.7			
28.8	2864	2.8	48.55	60.6	60.6				
16.6	4753	1.3	168.56	65.0	65.0	K90390 132M2	273	104	
18.5	4261	1.4	151.10	65.0	65.0				
20.5	3859	1.6	136.87	65.0	65.0				
22.2	3559	1.7	126.23	65.0	65.0				
26.6	2966	2.1	105.17	65.0	65.0				
29.5	2676	2.3	94.90	65.0	65.0				
31.5	2506	2.4	88.87	65.0	65.0				
32.7	2412	2.5	85.54	65.0	65.0				
35.6	2221	2.7	78.76	65.0	65.0				
38.8	2035	3.0	72.16	65.0	65.0				
12.9	6499	0.8	69.66	38.0	38.0	K70390 160M6	207	102	
14.2	5912	0.9	63.37	37.7	37.7				
15.4	5441	1.0	58.32	37.3	37.3				
16.7	5036	1.0	53.98	37.0	37.0				
17.3	4844	1.1	51.92	36.8	36.8				
18.8	4458	1.2	47.78	36.3	36.3				
20.6	4071	1.2	43.64	35.8	35.8				
22.9	3664	1.4	39.27	35.2	35.2				
24.9	3377	1.5	36.20	34.6	34.6				
28.0	3002	1.6	32.18	33.9	33.9				
30.3	2767	1.8	29.66	33.3	33.3				
33.2	2527	1.9	27.09	32.6	32.6				
36.1	2323	2.1	24.90	41.6	32.1				
40.1	2093	2.2	22.43	41.6	31.3				
44.1	1903	2.2	20.40	41.6	30.7				
49.0	1715	2.2	18.38	41.6	29.8				
53.6	1566	2.1	16.79	41.6	29.1				
63.2	1328	2.5	14.23	41.6	27.9				
77.3	1087	3.0	11.65	41.6	26.0				
12.8	6462	0.8	109.54	-	42.5	K70390 132M4	171	102	
13.4	6175	0.8	104.68	-	42.4				
15.0	5492	0.9	93.09	38.5	38.5				
16.7	4935	1.0	83.66	38.4	38.4				
18.4	4499	1.1	76.27	38.2	38.2				
20.1	4109	1.2	69.66	38.0	38.0				
22.1	3738	1.3	63.37	37.7	37.7				
24.0	3440	1.5	58.32	37.3	37.3				
25.9	3184	1.6	53.98	37.0	37.0				
27.0	3063	1.6	51.92	36.8	36.8				
29.3	2819	1.8	47.78	36.3	36.3				
32.1	2574	1.9	43.64	35.8	35.8				
35.7	2317	2.1	39.27	35.2	35.2				
38.7	2136	2.2	36.20	34.6	34.6				
43.5	1898	2.5	32.18	33.9	33.9				
47.2	1750	2.7	29.66	33.3	33.3				
51.7	1598	2.9	27.09	32.6	32.6				



P ₁ [kW]	n ₂ [Min ⁻¹]	M ₂ [Nm]	f _B	i _{ges}	FR (a) [kN]	FR (b) [kN]	Typ / Type / Tipo / Type / Tipo IE2 / IE3	 ~	
9.20	17.2	4596	0.8	162.98	38.5	45.0	K70390 132M2	171	102
	19.1	4128	0.9	146.38	38.5	45.0			
	21.0	3765	1.0	133.53	38.5	45.0			
	23.0	3439	1.1	121.96	38.5	45.0			
	25.6	3089	1.2	109.54	38.5	42.5			
	26.7	2952	1.3	104.68	38.5	42.4			
	30.1	2625	1.4	93.09	38.5	38.5			
	33.5	2359	1.6	83.66	38.4	38.4			
	36.7	2151	1.8	76.27	38.2	38.2			
	40.2	1964	1.9	69.66	38.0	38.0			
	44.2	1787	2.1	63.37	37.7	37.7			
	48.0	1644	2.3	58.32	37.3	37.3			
	51.9	1522	2.5	53.98	37.0	37.0			
	53.9	1464	2.6	51.92	36.8	36.8			
	58.6	1347	2.8	47.78	36.3	36.3			
64.2	1231	3.0	43.64	35.8	35.8				
	21.8	3849	0.8	41.26	30.0	8.8	K60390 160M6	165	100
	25.5	3289	0.9	35.25	30.0	8.6			
	28.3	2964	1.0	31.77	29.8	8.5			
	28.7	2929	1.0	31.39	29.7	8.5			
	32.0	2623	1.1	28.11	29.2	8.3			
	34.2	2455	1.2	26.31	28.9	8.3			
	38.7	2171	1.4	23.27	28.2	8.1			
	42.9	1959	1.3	21.00	27.7	7.9			
	47.6	1765	1.3	18.92	27.1	7.7			
	57.4	1462	1.5	15.67	26.0	7.4			
	63.6	1320	1.7	14.15	25.3	7.2			
	70.6	1190	1.8	12.75	24.7	7.1			
	85.2	985	2.1	10.56	30.0	6.7			
	93.5	898	2.1	9.63	30.0	6.6			
	112.9	744	2.1	7.97	30.0	6.3			
	18.5	4460	0.8	75.60	-	10.0	K60390 132M4	129	100
	19.8	4166	0.8	70.62	-	9.9			
	22.0	3755	0.9	63.65	30.0	9.0			
	23.2	3560	0.9	60.34	30.0	9.0			
	25.3	3261	1.0	55.28	30.0	9.0			
	27.7	2983	1.1	50.56	30.0	9.0			
	30.7	2688	1.1	45.57	30.0	8.9			
	33.9	2434	1.2	41.26	30.0	8.8			
	39.7	2079	1.3	35.25	30.0	8.6			
	44.1	1874	1.5	31.77	29.8	8.5			
	44.6	1852	1.5	31.39	29.7	8.5			
	49.8	1658	1.7	28.11	29.2	8.3			
	53.2	1552	1.8	26.31	28.9	8.3			
	60.2	1373	2.0	23.27	28.2	8.1			
	66.7	1239	2.0	21.00	27.7	7.9			
	74.0	1116	2.0	18.92	27.1	7.7			
	89.3	924	2.3	15.67	26.0	7.4			
	98.9	835	2.5	14.15	25.3	7.2			
	109.8	752	2.7	12.75	24.7	7.1			
	23.1	3423	0.8	121.39	30.0	13.1	K60390 132M2	129	100
	25.9	3054	0.9	108.31	30.0	11.6			
	27.6	2856	0.9	101.29	30.0	11.5			
	30.7	2574	1.0	91.30	30.0	11.4			
	34.5	2289	1.2	81.18	30.0	10.0			
	37.0	2132	1.2	75.60	30.0	10.0			
	39.6	1991	1.3	70.62	30.0	9.9			
	44.0	1795	1.4	63.65	30.0	9.0			
	46.4	1701	1.4	60.34	30.0	9.0			
	50.7	1559	1.6	55.28	30.0	9.0			
	55.4	1426	1.7	50.56	30.0	9.0			
	61.4	1285	1.8	45.57	30.0	8.9			
	67.9	1163	1.8	41.26	30.0	8.8			
	79.4	994	2.1	35.25	30.0	8.6			
	88.1	896	2.4	31.77	29.8	8.5			
	89.2	885	2.4	31.39	29.7	8.5			
	99.6	793	2.7	28.11	29.2	8.3			
	106.4	742	2.9	26.31	28.9	8.3			



P ₁ [kW]	n ₂ [Min ⁻¹]	M ₂ [Nm]	f _B	i _{ges}	FR (a) [kN]	FR (b) [kN]	Typ / Type / Tipo / Type / Tipo IE2 / IE3	 ~	 mm			
9.20	48.1	1745	0.8	18.70	19.6	5.6	K50390 160M6	138	98			
	53.1	1581	0.9	16.95	19.2	5.5						
	61.4	1367	0.9	14.65	18.5	5.3						
	76.4	1099	1.0	11.78	17.5	5.0						
	84.3	996	1.1	10.68	17.1	4.9						
	100.2	838	1.1	8.98	16.2	4.6						
	110.7	758	1.1	8.13	15.8	4.5						
	39.7	2082	0.8	35.30	-	6.7				K50390 132M4	102	98
	43.0	1920	0.9	32.54	21.9	6.3						
	47.2	1750	0.9	29.67	21.6	6.2						
	54.6	1513	1.0	25.65	21.0	6.0						
	60.2	1372	1.0	23.26	20.6	5.9						
	74.9	1103	1.3	18.70	19.6	5.6						
	82.6	1000	1.4	16.95	19.2	5.5						
	95.6	864	1.4	14.65	18.5	5.3						
	118.8	695	1.4	11.78	17.5	5.0						
	131.1	630	1.6	10.68	17.1	4.9						
	155.9	530	1.7	8.98	16.2	4.6						
	172.2	480	1.7	8.13	15.8	4.5						
	49.2	1606	0.8	56.96	21.9	8.0	K50390 132M2	102	98			
	54.2	1456	0.9	51.63	21.9	7.7						
	57.3	1379	0.9	48.89	21.9	7.6						
	60.1	1314	1.0	46.59	21.9	7.5						
	63.8	1238	1.0	43.91	21.9	7.4						
	69.2	1141	1.1	40.46	21.9	7.2						
	79.3	995	1.3	35.30	21.9	6.7						
	86.0	918	1.4	32.54	21.9	6.3						
	94.4	837	1.5	29.67	21.6	6.2						
	109.2	723	1.6	25.65	21.0	6.0						
	120.4	656	1.6	23.26	20.6	5.9						
	149.7	527	2.0	18.70	19.6	5.6						
	165.2	478	2.2	16.95	19.2	5.5						
	191.1	413	2.2	14.65	18.5	5.3						
	237.7	332	2.3	11.78	17.5	5.0						
	262.2	301	2.5	10.68	17.1	4.9						
	311.8	253	2.7	8.98	16.2	4.6						
	344.4	229	2.7	8.13	15.8	4.5						
	77.9	1061	0.8	17.98	-	4.3	K40390 132M4	84	96			
	85.9	961	0.9	16.29	14.1	4.0						
	99.2	832	1.0	14.11	13.8	3.9						
	123.6	668	1.1	11.33	13.3	3.8						
	136.5	605	1.1	10.26	13.0	3.7						
	162.2	509	1.2	8.63	12.4	3.6						
	179.0	461	1.1	7.82	12.2	3.5						
	97.1	813	0.8	28.83	14.1	5.4				K40390 132M2	84	96
107.2	736	0.9	26.11	14.1	5.0							
125.0	632	1.0	22.40	14.1	4.8							
155.7	507	1.3	17.98	14.1	4.3							
171.9	459	1.4	16.29	14.1	4.0							
198.4	398	1.5	14.11	13.8	3.9							
247.1	319	1.8	11.33	13.3	3.8							
272.9	289	1.7	10.26	13.0	3.7							
324.4	243	1.9	8.63	12.4	3.6							
358.1	221	1.7	7.82	12.2	3.5							
11.00	5.9	17038	0.8	152.74	80.0	65.0	K100390 160L6B / 160L6D	540	106			
	6.6	15277	0.9	136.95	80.0	65.0						
	7.2	13894	1.0	124.56	80.0	65.0						
	8.0	12567	1.1	112.66	80.0	65.0						
	8.8	11430	1.2	102.47	80.0	65.0						
	9.5	10580	1.3	94.85	80.0	65.0						
	10.4	9623	1.4	86.27	80.0	65.0						
	11.9	8429	1.6	75.56	80.0	65.0						
	13.1	7666	1.8	68.72	80.0	65.0						
	15.5	6471	2.1	58.01	80.0	65.0						
	17.1	5885	2.3	52.76	80.0	65.0						
	17.9	5612	2.4	50.31	80.0	65.0						
	20.3	4948	2.5	44.36	80.0	65.0						
	22.5	4470	3.0	40.07	80.0	65.0						



P ₁ [kW]	n ₂ [Min ⁻¹]	M ₂ [Nm]	f _B	i _{ges}	FR (a) [kN]	FR (b) [kN]	Typ / Type / Tipo / Type / Tipo IE2 / IE3	Kg ~	mm
11.00	9.2	10773	1.2	152.74	80.0	65.0	K100390 160M4C	540	106
	10.2	9660	1.3	136.95	80.0	65.0			
	11.2	8786	1.5	124.56	80.0	65.0			
	12.4	7946	1.6	112.66	80.0	65.0			
	13.7	7228	1.8	102.47	80.0	65.0			
	14.8	6690	1.9	94.85	80.0	65.0			
	16.2	6085	2.1	86.27	80.0	65.0			
	18.5	5330	2.4	75.56	80.0	65.0			
	20.4	4847	2.7	68.72	80.0	65.0			
	18.3	5150	1.9	152.74	80.0	65.0			
	20.4	4617	2.1	136.95	80.0	65.0			
	22.5	4200	2.4	124.56	80.0	65.0			
	24.9	3798	2.6	112.66	80.0	65.0			
	27.3	3455	2.9	102.47	80.0	65.0			
	9.5	10586	0.8	94.90	65.0	65.0	K90390 160L6B / 160L6D	317	104
	10.1	9913	0.8	88.87	65.0	65.0			
	10.5	9542	0.9	85.54	65.0	65.0			
	11.4	8786	1.0	78.76	65.0	65.0			
	12.5	8049	1.0	72.16	65.0	65.0			
	13.9	7232	1.2	64.83	64.8	64.8			
	14.5	6939	1.2	62.21	64.1	64.1			
	15.4	6526	1.3	58.50	63.0	63.0			
	16.2	6185	1.4	55.45	62.2	62.2			
	17.4	5759	1.5	51.63	60.9	60.9			
	18.5	5416	1.6	48.55	59.8	59.8			
	21.0	4790	1.8	42.94	57.9	57.9			
	22.6	4433	1.9	39.74	56.5	55.1			
	25.1	3999	2.1	35.85	65.0	53.5			
	26.3	3813	2.2	34.18	65.0	54.2			
	29.2	3440	2.4	30.84	65.0	52.6			
	31.3	3203	2.6	28.71	65.0	50.4			
	35.2	2856	2.5	25.60	65.0	49.7			
	36.7	2733	2.6	24.50	65.0	48.1			
	43.0	2337	2.9	20.95	65.0	46.0			
	47.6	2108	3.0	18.90	65.0	44.7			
	57.4	1750	3.0	15.69	65.0	42.2			
	9.3	10658	0.8	151.10	-	65.0	K90390 160M4C	317	104
	10.2	9654	0.8	136.87	65.0	65.0			
	11.1	8903	0.9	126.23	65.0	65.0			
	13.3	7418	1.1	105.17	65.0	65.0			
	14.8	6694	1.2	94.90	65.0	65.0			
	15.8	6268	1.3	88.87	65.0	65.0			
	16.4	6033	1.3	85.54	65.0	65.0			
	17.8	5555	1.4	78.76	65.0	65.0			
	19.4	5090	1.6	72.16	65.0	65.0			
21.6	4573	1.7	64.83	64.8	64.8				
22.5	4388	1.8	62.21	64.1	64.1				
23.9	4126	1.9	58.50	63.0	63.0				
25.2	3911	2.0	55.45	62.2	62.2				
27.1	3642	2.2	51.63	60.9	60.9				
28.8	3424	2.3	48.55	59.8	59.8				
32.6	3029	2.6	42.94	57.9	57.9				
35.2	2803	2.9	39.74	56.5	55.1				
16.6	5683	1.1	168.56	65.0	65.0	K90390 160M2B / 160M2C	317	104	
18.5	5094	1.2	151.10	65.0	65.0				
20.5	4615	1.3	136.87	65.0	65.0				
22.2	4256	1.4	126.23	65.0	65.0				
26.6	3546	1.7	105.17	65.0	65.0				
29.5	3200	1.9	94.90	65.0	65.0				
31.5	2996	2.0	88.87	65.0	65.0				
32.7	2884	2.1	85.54	65.0	65.0				
35.6	2655	2.3	78.76	65.0	65.0				
38.8	2433	2.5	72.16	65.0	65.0				
43.2	2186	2.8	64.83	64.8	64.8				
45.0	2097	2.9	62.21	64.1	64.1				



P ₁ [kW]	n ₂ [Min ⁻¹]	M ₂ [Nm]	f _B	i _{ges}	FR (a) [kN]	FR (b) [kN]	Typ / Type / Tipo / Type / Tipo IE2 / IE3	 ~					
11.00	15.4	6505	0.8	58.32	35.0	35.0	K70390 160L6B / 160L6D	207	102				
	16.7	6021	0.9	53.98	34.8	34.8							
	17.3	5792	0.9	51.92	34.7	34.7							
	18.8	5330	1.0	47.78	34.4	34.4							
	20.6	4868	1.0	43.64	34.0	34.0							
	22.9	4380	1.2	39.27	33.6	33.6							
	24.9	4038	1.2	36.20	33.2	33.2							
	28.0	3590	1.4	32.18	32.6	32.6							
	30.3	3309	1.5	29.66	32.1	32.1							
	33.2	3022	1.6	27.09	31.5	31.5							
	36.1	2778	1.7	24.90	31.1	31.1							
	40.1	2502	1.8	22.43	30.4	30.4							
	44.1	2276	1.8	20.40	29.8	29.8							
	49.0	2050	1.8	18.38	29.1	29.1							
	53.6	1873	1.8	16.79	28.4	28.4							
	63.2	1587	2.1	14.23	38.0	27.3							
	77.3	1300	2.5	11.65	38.0	26.0							
	84.6	1187	2.7	10.64	38.0	24.4							
		15.0	6566	0.8	93.09	38.5				38.5	K70390 160M4C	207	102
		16.7	5901	0.8	83.66	41.6				38.4			
		18.4	5380	0.9	76.27	35.2	35.2						
		20.1	4913	1.0	69.66	35.2	35.2						
		22.1	4470	1.1	63.37	35.1	35.1						
		24.0	4114	1.2	58.32	35.0	35.0						
		25.9	3807	1.3	53.98	34.8	34.8						
		27.0	3662	1.4	51.92	34.7	34.7						
		29.3	3370	1.5	47.78	34.4	34.4						
		32.1	3078	1.6	43.64	34.0	34.0						
		35.7	2770	1.7	39.27	33.6	33.6						
		38.7	2553	1.9	36.20	33.2	33.2						
		43.5	2270	2.1	32.18	32.6	32.6						
		47.2	2092	2.2	29.66	32.1	32.1						
		51.7	1911	2.4	27.09	31.5	31.5						
		56.2	1756	2.6	24.90	31.1	31.1						
		62.4	1582	2.8	22.43	30.4	30.4						
		68.6	1439	2.8	20.40	29.8	29.8						
		76.2	1296	2.8	18.38	29.1	29.1						
		83.4	1184	2.7	16.79	28.4	28.4						
		19.1	4935	0.8	146.38	38.5	45.0	K70390 160M2B / 160M2C	207	102			
		21.0	4502	0.8	133.53	38.5	45.0						
		23.0	4112	0.9	121.96	38.5	45.0						
		25.6	3693	1.0	109.54	38.5	42.5						
		30.1	3139	1.2	93.09	38.5	38.5						
		33.5	2821	1.3	83.66	41.6	38.4						
		36.7	2571	1.5	76.27	35.2	35.2						
		40.2	2349	1.6	69.66	35.2	35.2						
		44.2	2137	1.8	63.37	35.1	35.1						
		48.0	1966	1.9	58.32	35.0	35.0						
		51.9	1820	2.1	53.98	34.8	34.8						
		53.9	1750	2.2	51.92	34.7	34.7						
		58.6	1611	2.4	47.78	34.4	34.4						
		64.2	1471	2.5	43.64	34.0	34.0						
		71.3	1324	2.8	39.27	33.6	33.6						
		77.3	1220	3.0	36.20	33.2	33.2						
		28.3	3544	0.8	31.77	28.2	8.1	K60390 160L6B / 160L6D	165	100			
		28.7	3501	0.8	31.39	28.2	8.1						
		32.0	3136	0.9	28.11	27.8	7.9						
		34.2	2935	1.0	26.31	27.6	7.9						
		38.7	2596	1.1	23.27	27.1	7.7						
		42.9	2343	1.1	21.00	26.6	7.6						
		47.6	2110	1.1	18.92	26.1	7.5						
		57.4	1748	1.3	15.67	25.2	7.2						
		63.6	1578	1.4	14.15	24.6	7.0						
		70.6	1422	1.5	12.75	24.1	6.9						
		85.2	1178	1.8	10.56	23.0	6.6						
		93.5	1074	1.8	9.63	22.6	6.5						
		112.9	889	1.8	7.97	21.6	6.2						



P ₁ [kW]	n ₂ [Min ⁻¹]	M ₂ [Nm]	f _B	i _{ges}	FR (a) [kN]	FR (b) [kN]	Typ / Type / Tipo / Type / Tipo IE2 / IE3	 Kg ~	 mm
11.00	23.2	4256	0.8	60.34	30.0	9.0	K60390 160M4C	165	100
	25.3	3899	0.8	55.28	30.0	9.0			
	27.7	3566	0.9	50.56	28.8	8.2			
	30.7	3214	0.9	45.57	28.9	8.2			
	33.9	2910	1.0	41.26	28.8	8.2			
	39.7	2486	1.1	35.25	28.5	8.1			
	44.1	2241	1.2	31.77	28.2	8.1			
	44.6	2214	1.3	31.39	28.2	8.1			
	49.8	1983	1.4	28.11	27.8	7.9			
	53.2	1856	1.5	26.31	27.6	7.9			
	60.2	1641	1.7	23.27	27.1	7.7			
	66.7	1481	1.7	21.00	26.6	7.6			
	74.0	1334	1.6	18.92	26.1	7.5			
	89.3	1105	1.9	15.67	25.2	7.2			
	98.9	998	2.1	14.15	24.6	7.0			
	109.8	899	2.2	12.75	24.1	6.9	K60390 160M2B / 160M2C	165	100
	132.6	745	2.7	10.56	23.0	6.6			
	145.4	679	2.7	9.63	22.6	6.5			
	175.7	562	2.7	7.97	21.6	6.2			
	27.6	3415	0.8	101.29	30.0	11.5			
	30.7	3078	0.9	91.30	30.0	11.4			
	37.0	2549	1.0	75.60	30.0	11.2			
	39.6	2381	1.1	70.62	30.0	11.1			
	44.0	2146	1.2	63.65	30.0	9.0			
	46.4	2034	1.2	60.34	30.0	9.0			
	50.7	1864	1.3	55.28	30.0	9.0			
	55.4	1705	1.4	50.56	28.8	8.2			
	61.4	1536	1.5	45.57	28.9	8.2			
	67.9	1391	1.5	41.26	28.8	8.2			
	79.4	1188	1.8	35.25	28.5	8.1			
	88.1	1071	2.0	31.77	28.2	8.1	K50390 160L6B / 160L6D	138	98
	89.2	1058	2.0	31.39	28.2	8.1			
	99.6	948	2.2	28.11	27.8	7.9			
	106.4	887	2.4	26.31	27.6	7.9			
	120.3	785	2.7	23.27	27.1	7.7			
	133.3	708	2.7	21.00	26.6	7.6			
	148.0	638	2.6	18.92	26.1	7.5	K50390 160M4C	138	98
	178.7	528	3.0	15.67	25.2	7.2			
	53.1	1891	0.8	16.95	18.6	5.3			
	61.4	1634	0.8	14.65	18.0	5.2			
	76.4	1314	0.8	11.78	17.1	4.9			
	84.3	1191	0.9	10.68	16.7	4.8			
	100.2	1002	0.9	8.98	15.9	4.5	K50390 160M2B / 160M2C	138	98
	110.7	907	0.9	8.13	15.5	4.4			
	47.2	2093	0.8	29.67	22.0	6.2			
	54.6	1809	0.8	25.65	-	6.0			
	60.2	1641	0.9	23.26	20.6	5.9			
	74.9	1319	1.1	18.70	19.0	5.4			
	82.6	1196	1.2	16.95	18.6	5.3	K50390 160M2B / 160M2C	138	98
	95.6	1033	1.2	14.65	18.0	5.2			
	118.8	831	1.2	11.78	17.1	4.9			
	131.1	753	1.3	10.68	16.7	4.8			
	155.9	633	1.4	8.98	15.9	4.5			
	172.2	573	1.4	8.13	15.5	4.4			
	94.4	1000	1.2	29.67	22.0	6.2	K50390 160M2B / 160M2C	138	98
	109.2	865	1.3	25.65	20.6	6.0			
	120.4	784	1.4	23.26	20.6	5.9			
	149.7	630	1.7	18.70	19.0	5.4			
	165.2	571	1.9	16.95	18.6	5.3			
	191.1	494	1.8	14.65	18.0	5.2			
	237.7	397	1.9	11.78	17.1	4.9			
	262.2	360	2.1	10.68	16.7	4.8			
	311.8	303	2.3	8.98	15.9	4.5			
	344.4	274	2.2	8.13	15.5	4.4			



P ₁ [kW]	n ₂ [Min ⁻¹]	M ₂ [Nm]	f _B	i _{ges}	FR (a) [kN]	FR (b) [kN]	Typ / Type / Tipo / Type / Tipo IE2 / IE3	 ~		
15.00	8.0	17137	0.8	112.66	80.0	65.0	K100390 180L6A / 180L6B	581	106	
	8.8	15587	0.9	102.47	80.0	65.0				
	9.5	14428	0.9	94.85	80.0	65.0				
	10.4	13123	1.0	86.27	80.0	65.0				
	11.9	11494	1.2	75.56	80.0	65.0				
	13.1	10453	1.3	68.72	80.0	65.0				
	15.5	8824	1.5	58.01	80.0	65.0				
	17.1	8025	1.7	52.76	80.0	65.0				
	17.9	7653	1.8	50.31	80.0	65.0				
	20.3	6748	1.9	44.36	80.0	65.0				
	22.5	6095	2.2	40.07	80.0	65.0				
	24.4	5622	2.3	36.96	80.0	65.0				
	26.8	5114	2.4	33.62	80.0	65.0				
	29.7	4614	2.6	30.33	80.0	65.0				
	31.8	4300	2.5	28.27	80.0	65.0				
	34.6	3956	2.9	26.01	80.0	65.0				
		9.2	14691	0.9	152.74	80.0	65.0	K100390 160L4B	540	106
		10.2	13172	1.0	136.95	80.0	65.0			
		11.2	11980	1.1	124.56	80.0	65.0			
		12.4	10836	1.2	112.66	80.0	65.0			
		13.7	9856	1.3	102.47	80.0	65.0			
		14.8	9123	1.4	94.85	80.0	65.0			
		16.2	8298	1.6	86.27	80.0	65.0			
		18.5	7268	1.8	75.56	80.0	65.0			
		20.4	6610	2.0	68.72	80.0	65.0			
		24.1	5580	2.3	58.01	80.0	65.0			
		26.5	5075	2.6	52.76	80.0	65.0			
		27.8	4839	2.7	50.31	80.0	65.0			
		31.6	4267	2.8	44.36	80.0	65.0			
		18.3	7022	1.4	152.74	80.0	65.0	K100390 160M2C / 160M2D	540	106
		20.4	6296	1.6	136.95	80.0	65.0			
		22.5	5727	1.7	124.56	80.0	65.0			
		24.9	5180	1.9	112.66	80.0	65.0			
		27.3	4711	2.1	102.47	80.0	65.0			
		29.5	4361	2.3	94.85	80.0	65.0			
		32.5	3966	2.5	86.27	80.0	65.0			
		37.1	3474	2.8	75.56	80.0	65.0			
	12.5	10976	0.8	72.16	64.2	64.2	K90390 180L6A / 180L6B	358	104	
	13.9	9861	0.9	64.83	62.5	62.5				
	14.5	9463	0.9	62.21	61.9	61.9				
	15.4	8898	0.9	58.50	60.9	60.9				
	16.2	8435	1.0	55.45	60.2	60.2				
	17.4	7853	1.1	51.63	59.0	59.0				
	18.5	7385	1.1	48.55	58.1	58.1				
	21.0	6532	1.3	42.94	56.3	56.3				
	22.6	6045	1.4	39.74	55.1	55.1				
	25.1	5453	1.5	35.85	53.5	53.5				
	26.3	5199	1.6	34.18	53.0	53.0				
	29.2	4691	1.8	30.84	51.5	51.5				
	31.3	4367	1.9	28.71	50.4	50.4				
	35.2	3894	1.8	25.60	48.8	48.8				
	36.7	3727	1.9	24.50	48.1	48.1				
	43.0	3187	2.1	20.95	65.0	46.0				
	47.6	2875	2.2	18.90	65.0	44.7				
	57.4	2387	2.2	15.69	65.0	42.2				
	62.8	2178	2.4	14.32	65.0	41.0				
	69.7	1965	2.4	12.92	65.0	39.8				
	84.0	1631	2.9	10.72	65.0	37.2				



P ₁ [kW]	n ₂ [Min ⁻¹]	M ₂ [Nm]	f _B	i _{ges}	FR (a) [kN]	FR (b) [kN]	Typ / Type / Tipo / Type / Tipo IE2 / IE3	 ~	
15.00	13.3	10115	0.8	105.17	65.0	65.0	K90390 160L4B	317	104
	14.8	9128	0.9	94.90	65.0	65.0			
	15.8	8548	0.9	88.87	65.0	65.0			
	16.4	8227	1.0	85.54	65.0	65.0			
	17.8	7575	1.1	78.76	65.0	65.0			
	19.4	6941	1.2	72.16	64.2	64.2			
	21.6	6235	1.3	64.83	62.5	62.5			
	22.5	5983	1.3	62.21	61.9	61.9			
	23.9	5627	1.4	58.50	60.9	60.9			
	25.2	5333	1.5	55.45	60.2	60.2			
	27.1	4966	1.6	51.63	59.0	59.0			
	28.8	4670	1.7	48.55	58.1	58.1			
	32.6	4130	1.9	42.94	56.3	56.3			
	35.2	3822	2.1	39.74	55.1	55.1			
	39.1	3448	2.3	35.85	53.5	53.5			
	41.0	3288	2.4	34.18	53.0	53.0			
	45.4	2966	2.7	30.84	51.5	51.5			
	48.8	2761	2.9	28.71	50.4	50.4			
	54.7	2462	2.8	25.60	48.8	48.8			
	57.1	2356	2.8	24.50	48.1	48.1			
	16.6	7749	0.8	168.56	65.0	65.0	K90390 160M2C / 160M2D	317	104
	18.5	6947	0.9	151.10	65.0	65.0			
	20.5	6293	1.0	136.87	65.0	65.0			
	22.2	5803	1.0	126.23	65.0	65.0			
	26.6	4835	1.3	105.17	65.0	65.0			
	29.5	4363	1.4	94.90	65.0	65.0			
	31.5	4086	1.5	88.87	65.0	65.0			
	32.7	3933	1.5	85.54	65.0	65.0			
	35.6	3621	1.7	78.76	65.0	65.0			
	38.8	3318	1.8	72.16	64.2	64.2			
	43.2	2981	2.0	64.83	62.5	62.5			
	45.0	2860	2.1	62.21	61.9	61.9			
	47.9	2690	2.3	58.50	60.9	60.9			
	50.5	2549	2.4	55.45	60.2	60.2			
	54.2	2374	2.6	51.63	59.0	59.0			
	57.7	2232	2.7	48.55	58.1	58.1			
20.6	6638	0.8	43.64	30.1	30.1	K70390 180L6A / 180L6B	248	102	
22.9	5973	0.8	39.27	30.1	30.1				
24.9	5506	0.9	36.20	29.9	29.9				
28.0	4895	1.0	32.18	29.7	29.7				
30.3	4512	1.1	29.66	29.4	29.4				
33.2	4121	1.2	27.09	29.1	29.1				
36.1	3788	1.3	24.90	28.9	28.9				
40.1	3412	1.4	22.43	28.4	28.4				
44.1	3103	1.4	20.40	28.0	28.0				
49.0	2796	1.4	18.38	27.4	27.4				
53.6	2554	1.3	16.79	26.9	26.9				
63.2	2165	1.5	14.23	26.1	26.1				
77.3	1772	1.8	11.65	25.0	25.0				
84.6	1618	1.9	10.64	24.4	24.4				
22.1	6095	0.8	63.37	35.1	35.1	K70390 160L4B	207	102	
24.0	5609	0.9	58.32	29.8	29.8				
25.9	5192	1.0	53.98	30.0	30.0				
27.0	4994	1.0	51.92	30.0	30.0				
29.3	4596	1.1	47.78	30.1	30.1				
32.1	4197	1.1	43.64	30.1	30.1				
35.7	3777	1.3	39.27	30.1	30.1				
38.7	3482	1.4	36.20	29.9	29.9				
43.5	3095	1.5	32.18	29.7	29.7				
47.2	2853	1.6	29.66	29.4	29.4				
51.7	2606	1.8	27.09	29.1	29.1				
56.2	2395	1.9	24.90	28.9	28.9				
62.4	2157	2.0	22.43	28.4	28.4				
68.6	1962	2.0	20.40	28.0	28.0				
76.2	1768	2.0	18.38	27.4	27.4				
83.4	1615	2.0	16.79	26.9	26.9				
98.4	1369	2.3	14.23	26.1	26.1				
120.2	1121	2.8	11.65	25.0	25.0				
131.6	1023	2.9	10.64	24.4	24.4				



P ₁ [kW]	n ₂ [Min ⁻¹]	M ₂ [Nm]	f _B	i _{ges}	FR (a) [kN]	FR (b) [kN]	Typ / Type / Tipo / Type / Tipo IE2 / IE3	 ~					
15.00	25.6	5036	0.8	109.54	35.1	42.5	K70390 160M2C / 160M2D	207	102				
	30.1	4280	0.9	93.09	35.1	38.5							
	33.5	3846	1.0	83.66	35.1	38.4							
	36.7	3506	1.1	76.27	35.1	35.2							
	40.2	3203	1.2	69.66	35.1	35.2							
	44.2	2913	1.3	63.37	35.1	35.1							
	48.0	2681	1.4	58.32	29.8	29.8							
	51.9	2482	1.5	53.98	30.0	30.0							
	53.9	2387	1.6	51.92	30.0	30.0							
	58.6	2197	1.7	47.78	30.1	30.1							
	64.2	2006	1.8	43.64	30.1	30.1							
	71.3	1805	2.0	39.27	30.1	30.1							
	77.3	1664	2.2	36.20	29.9	29.9							
	87.0	1479	2.4	32.18	29.7	29.7							
	94.4	1364	2.6	29.66	29.4	29.4							
103.4	1245	2.8	27.09	29.1	29.1								
	38.7	3540	0.8	23.27	24.5	7.0	K60390 180L6A / 180L6B	206	100				
	42.9	3194	0.8	21.00	24.3	6.9							
	47.6	2878	0.8	18.92	24.0	6.9							
	57.4	2384	0.9	15.67	23.4	6.7							
	63.6	2152	1.0	14.15	23.1	6.6							
	70.6	1939	1.1	12.75	22.6	6.5							
	85.2	1606	1.3	10.56	21.9	6.2							
	93.5	1465	1.3	9.63	21.5	6.2							
	112.9	1212	1.3	7.97	20.7	5.9							
		39.7	3390	0.8	35.25	28.5				8.1	K60390 160L4B	165	100
		44.1	3056	0.9	31.77	24.7				7.1			
44.6		3019	0.9	31.39	24.7	7.1							
49.8		2704	1.0	28.11	24.7	7.1							
53.2		2531	1.1	26.31	24.7	7.0							
60.2		2238	1.3	23.27	24.5	7.0							
66.7		2020	1.2	21.00	24.3	6.9							
74.0		1820	1.2	18.92	24.0	6.9							
89.3		1507	1.4	15.67	23.4	6.7							
98.9		1361	1.5	14.15	23.1	6.6							
109.8		1226	1.6	12.75	22.6	6.5							
132.6		1016	2.0	10.56	21.9	6.2							
145.4		926	1.9	9.63	21.5	6.2							
175.7		767	2.0	7.97	20.7	5.9							
	37.0	3476	0.8	75.60	28.5	10.0	K60390 160M2C / 160M2D	165	100				
	39.6	3247	0.8	70.62	28.5	9.9							
	44.0	2926	0.9	63.65	28.5	9.0							
	46.4	2774	0.9	60.34	28.5	9.0							
	50.7	2541	1.0	55.28	28.5	9.0							
	55.4	2324	1.0	50.56	28.5	8.2							
	61.4	2095	1.1	45.57	28.5	8.2							
	67.9	1897	1.1	41.26	28.5	8.2							
	79.4	1621	1.3	35.25	28.5	8.1							
	88.1	1461	1.5	31.77	24.7	7.1							
	89.2	1443	1.5	31.39	24.7	7.1							
	99.6	1292	1.6	28.11	24.7	7.1							
	106.4	1210	1.8	26.31	24.7	7.0							
	120.3	1070	2.0	23.27	24.5	7.0							
	133.3	965	2.0	21.00	24.3	6.9							
	148.0	870	1.9	18.92	24.0	6.9							
	178.7	720	2.2	15.67	23.4	6.7							
	197.9	651	2.5	14.15	23.1	6.6							
	219.6	586	2.6	12.75	22.6	6.5							
		74.9	1799	0.8	18.70	19.0				5.4	K50390 160L4B	138	98
82.6		1630	0.9	16.95	18.6	5.3							
95.6		1409	0.9	14.65	18.0	5.2							
118.8		1133	0.9	11.78	16.3	4.7							
131.1		1027	1.0	10.68	16.0	4.6							
155.9		864	1.0	8.98	15.3	4.4							
172.2		782	1.0	8.13	14.9	4.3							



P ₁ [kW]	n ₂ [Min ⁻¹]	M ₂ [Nm]	f _B	i _{ges}	FR (a) [kN]	FR (b) [kN]	Typ / Type / Tipo / Type / Tipo IE2 / IE3	 ~	 mm		
15.00	94.4	1364	0.9	29.67	19.0	6.2	K50390 160M2C / 160M2D	138	98		
	109.2	1179	1.0	25.65	19.0	6.0					
	120.4	1069	1.0	23.26	19.0	5.9					
	149.7	860	1.2	18.70	19.0	5.4					
	165.2	779	1.4	16.95	18.6	5.3					
	191.1	674	1.4	14.65	18.0	5.2					
	237.7	542	1.4	11.78	16.3	4.7					
	262.2	491	1.5	10.68	16.0	4.6					
	311.8	413	1.7	8.98	15.3	4.4					
	344.4	374	1.6	8.13	14.9	4.3					
18.50	9.5	17794	0.8	94.85	80.0	65.0	K100390 200L6B / 200L6C	649	106		
	10.4	16185	0.8	86.27	80.0	65.0					
	11.9	14175	1.0	75.56	80.0	65.0					
	13.1	12892	1.1	68.72	80.0	65.0					
	15.5	10883	1.3	58.01	80.0	65.0					
	17.1	9898	1.4	52.76	80.0	65.0					
	17.9	9438	1.4	50.31	80.0	65.0					
	20.3	8322	1.5	44.36	80.0	65.0					
	22.5	7517	1.8	40.07	80.0	65.0					
	24.4	6934	1.9	36.96	80.0	65.0					
	26.8	6307	2.0	33.62	80.0	65.0					
	29.7	5690	2.1	30.33	79.7	65.0					
	31.8	5304	2.0	28.27	79.7	65.0					
	34.6	4880	2.4	26.01	80.0	65.0					
	38.0	4439	2.5	23.66	80.0	65.0					
	42.0	4020	2.7	21.43	80.0	65.0					
	10.2	16246	0.8	136.95	80.0	65.0	K100390 180M4A / 180M4B	581	106		
	11.2	14776	0.9	124.56	80.0	65.0					
	12.4	13364	1.0	112.66	80.0	65.0					
	13.7	12155	1.1	102.47	80.0	65.0					
	14.8	11252	1.2	94.85	80.0	65.0					
	16.2	10234	1.3	86.27	80.0	65.0					
	18.5	8963	1.5	75.56	80.0	65.0					
	20.4	8152	1.6	68.72	80.0	65.0					
	24.1	6881	1.9	58.01	80.0	65.0					
	26.5	6259	2.1	52.76	80.0	65.0					
	27.8	5968	2.2	50.31	80.0	65.0					
	31.6	5262	2.3	44.36	80.0	65.0					
	34.9	4753	2.7	40.07	80.0	65.0					
	37.9	4384	2.8	36.96	80.0	65.0					
	41.6	3988	3.0	33.62	80.0	65.0					
	49.5	3354	3.0	28.27	79.7	65.0					
	18.3	8661	1.1	152.74	80.0	65.0	K100390 160M2D / 160L2C	540	106		
	20.4	7765	1.3	136.95	80.0	65.0					
	22.5	7063	1.4	124.56	80.0	65.0					
	24.9	6388	1.5	112.66	80.0	65.0					
	27.3	5810	1.7	102.47	80.0	65.0					
	29.5	5378	1.8	94.85	80.0	65.0					
	32.5	4892	2.0	86.27	80.0	65.0					
	37.1	4284	2.3	75.56	80.0	65.0					
	40.7	3897	2.5	68.72	80.0	65.0					
	48.3	3289	3.0	58.01	80.0	65.0					
16.2	10403	0.8	55.45	58.5	58.5	K90390 200L6B / 200L6C	436	104			
21.0	8056	1.0	42.94	55.0	55.0						
22.6	7455	1.1	39.74	53.8	53.8						
25.1	6726	1.2	35.85	52.4	52.4						
36.7	4596	1.5	24.50	47.3	47.3						
43.0	3930	1.7	20.95	45.4	45.4						
47.6	3546	1.8	18.90	44.1	44.1						
57.4	2944	1.8	15.69	41.8	41.8						
62.8	2686	2.0	14.32	40.6	40.6						
69.7	2424	1.9	12.92	39.4	39.4						
84.0	2011	2.3	10.72	64.2	37.2						



P ₁ [kW]	n ₂ [Min ⁻¹]	M ₂ [Nm]	f _B	i _{ges}	FR (a) [kN]	FR (b) [kN]	Typ / Type / Tipo / Type / Tipo IE2 / IE3	 ~				
18.50	15.8	10542	0.8	88.87	65.0	65.0	K90390 180M4A / 180M4B	358	104			
	16.4	10147	0.8	85.54	65.0	65.0						
	17.8	9343	0.9	78.76	63.0	63.0						
	19.4	8560	0.9	72.16	62.0	62.0						
	21.6	7690	1.0	64.83	60.5	60.5						
	22.5	7380	1.1	62.21	59.9	59.9						
	23.9	6940	1.2	58.50	59.1	59.1						
	25.2	6578	1.2	55.45	58.5	58.5						
	27.1	6125	1.3	51.63	57.4	57.4						
	28.8	5759	1.4	48.55	56.6	56.6						
	32.6	5094	1.6	42.94	55.0	55.0						
	35.2	4714	1.7	39.74	53.8	53.8						
	39.1	4253	1.9	35.85	52.4	52.4						
	41.0	4055	2.0	34.18	51.9	51.9						
	45.4	3658	2.2	30.84	50.5	50.5						
	48.8	3406	2.3	28.71	49.5	49.5						
	54.7	3037	2.2	25.60	48.0	48.0						
	57.1	2906	2.3	24.50	47.3	47.3						
	66.8	2485	2.6	20.95	45.4	45.4						
	74.1	2242	2.7	18.90	44.1	44.1						
	89.2	1861	2.7	15.69	41.8	41.8						
	97.8	1699	2.9	14.32	40.6	40.6						
	108.4	1533	2.9	12.92	39.4	39.4						
	20.5	7761	0.8	136.87	65.0	65.0				K90390 160M2D / 160L2C	317	104
	22.2	7158	0.8	126.23	65.0	64.6						
	26.6	5963	1.0	105.17	65.0	61.4						
	29.5	5381	1.1	94.90	65.0	65.0						
	31.5	5039	1.2	88.87	65.0	65.0						
	32.7	4850	1.3	85.54	65.0	65.0						
	35.6	4466	1.4	78.76	63.0	63.0						
	38.8	4092	1.5	72.16	62.0	62.0						
	43.2	3676	1.7	64.83	60.5	60.5						
	45.0	3527	1.7	62.21	59.9	59.9						
	47.9	3317	1.8	58.50	59.1	59.1						
	50.5	3144	1.9	55.45	58.5	58.5						
	54.2	2928	2.1	51.63	57.4	57.4						
	57.7	2753	2.2	48.55	56.6	56.6						
	65.2	2435	2.5	42.94	55.0	55.0						
	70.5	2253	2.7	39.74	53.8	53.8						
78.1	2033	3.0	35.85	52.4	52.4							
28.0	6037	0.8	32.18	27.2	27.2	K70390 200L6B / 200L6C	306	102				
30.3	5564	0.9	29.66	27.1	27.1							
33.2	5082	1.0	27.09	27.0	27.0							
36.1	4671	1.0	24.90	26.9	26.9							
40.1	4208	1.1	22.43	26.6	26.6							
44.1	3827	1.1	20.40	26.4	26.4							
49.0	3448	1.1	18.38	26.0	26.0							
53.6	3150	1.1	16.79	25.6	25.6							
63.2	2670	1.2	14.23	25.0	25.0							
77.3	2186	1.5	11.65	24.0	24.0							
84.6	1996	1.6	10.64	23.6	23.6							
25.9	6403	0.8	53.98	30.0	29.8				K70390 180M4A / 180M4B	248	102	
27.0	6159	0.8	51.92	30.0	30.0							
29.3	5668	0.9	47.78	26.4	26.4							
32.1	5177	0.9	43.64	26.7	26.7							
35.7	4658	1.0	39.27	27.0	27.0							
38.7	4294	1.1	36.20	27.1	27.1							
43.5	3817	1.2	32.18	27.2	27.2							
47.2	3518	1.3	29.66	27.1	27.1							
51.7	3214	1.4	27.09	27.0	27.0							
56.2	2954	1.6	24.90	26.9	26.9							
62.4	2661	1.7	22.43	26.6	26.6							
68.6	2420	1.7	20.40	26.4	26.4							
76.2	2180	1.7	18.38	26.0	26.0							
83.4	1992	1.6	16.79	25.6	25.6							
98.4	1688	1.8	14.23	25.0	25.0							
120.2	1382	2.2	11.65	24.0	24.0							
131.6	1262	2.4	10.64	23.6	23.6							



P ₁ [kW]	n ₂ [Min ⁻¹]	M ₂ [Nm]	f _B	i _{ges}	FR (a) [kN]	FR (b) [kN]	Typ / Type / Tipo / Type / Tipo IE2 / IE3	 ~	 mm			
18.50	33.5	4744	0.8	83.66	30.0	38.4	K70390 160M2D / 160L2C	207	102			
	36.7	4325	0.9	76.27	30.0	35.2						
	40.2	3950	1.0	69.66	30.0	35.2						
	44.2	3593	1.1	63.37	30.0	35.1						
	48.0	3307	1.1	58.32	30.0	29.8						
	51.9	3061	1.2	53.98	30.0	30.0						
	53.9	2944	1.3	51.92	30.0	30.0						
	58.6	2709	1.4	47.78	26.4	26.4						
	64.2	2474	1.5	43.64	26.7	26.7						
	71.3	2227	1.6	39.27	27.0	27.0						
	77.3	2053	1.8	36.20	27.1	27.1						
	87.0	1825	2.0	32.18	27.2	27.2						
	94.4	1682	2.1	29.66	27.1	27.1						
	103.4	1536	2.3	27.09	27.0	27.0						
	112.4	1412	2.5	24.90	26.9	26.9						
	124.8	1272	2.6	22.43	26.6	26.6						
	137.3	1157	2.6	20.40	26.4	26.4						
	152.3	1042	2.6	18.38	26.0	26.0						
	166.8	952	2.6	16.79	25.6	25.6						
	196.8	807	2.9	14.23	25.0	25.0						
	44.6	3724	0.8	31.39	24.7	7.1				K60390 180M4A / 180M4B	206	100
	49.8	3335	0.8	28.11	27.0	7.1						
	53.2	3121	0.9	26.31	22.1	6.3						
	60.2	2760	1.0	23.27	22.2	6.4						
	66.7	2491	1.0	21.00	22.3	6.4						
	74.0	2244	1.0	18.92	22.2	6.3						
	89.3	1859	1.1	15.67	21.9	6.3						
	98.9	1679	1.3	14.15	21.7	6.2						
	109.8	1512	1.3	12.75	21.4	6.1						
	132.6	1253	1.6	10.56	20.8	6.0						
	145.4	1142	1.6	9.63	20.6	5.9						
	175.7	945	1.6	7.97	19.9	5.9						
	50.7	3134	0.8	55.28	24.7	9.0				K60390 160M2D / 160L2C	165	100
	55.4	2867	0.8	50.56	24.7	8.2						
	61.4	2584	0.9	45.57	24.7	8.2						
	67.9	2340	0.9	41.26	24.7	8.2						
79.4	1999	1.1	35.25	24.7	8.1							
88.1	1801	1.2	31.77	24.7	7.1							
89.2	1780	1.2	31.39	24.7	7.1							
99.6	1594	1.3	28.11	27.0	7.1							
106.4	1492	1.4	26.31	22.1	6.3							
120.3	1319	1.6	23.27	22.2	6.4							
133.3	1191	1.6	21.00	22.3	6.4							
148.0	1073	1.6	18.92	22.2	6.3							
178.7	889	1.8	15.67	21.9	6.3							
197.9	802	2.0	14.15	21.7	6.2							
219.6	723	2.1	12.75	21.4	6.1							
265.2	599	2.5	10.56	20.8	6.0							
290.8	546	2.5	9.63	20.6	5.9							
351.3	452	2.5	7.97	19.9	5.7							
109.2	1454	0.8	25.65	19.0	6.0	K50390 160M2D / 160L2C	138	98				
120.4	1319	0.8	23.26	19.0	5.9							
149.7	1060	1.0	18.70	19.0	5.4							
165.2	961	1.1	16.95	19.0	5.3							
191.1	831	1.1	14.65	19.0	5.2							
237.7	668	1.1	11.78	19.0	4.7							
262.2	606	1.3	10.68	19.0	4.6							
311.8	509	1.3	8.98	19.0	4.4							
344.4	461	1.3	8.13	19.0	4.3							



P ₁ [kW]	n ₂ [Min ⁻¹]	M ₂ [Nm]	f _B	i _{ges}	FR (a) [kN]	FR (b) [kN]	Typ / Type / Tipo / Type / Tipo IE2 / IE3	 ~		
22.00	11.9	16857	0.8	75.56	80.0	65.0	K100390 200L6C / 200L6D	649	106	
	13.1	15331	0.9	68.72	80.0	65.0				
	15.5	12942	1.1	58.01	80.0	65.0				
	17.1	11771	1.2	52.76	80.0	65.0				
	17.9	11224	1.2	50.31	80.0	65.0				
	20.3	9897	1.3	44.36	80.0	65.0				
	22.5	8939	1.5	40.07	80.0	65.0				
	24.4	8246	1.6	36.96	80.0	65.0				
	26.8	7500	1.7	33.62	80.0	65.0				
	29.7	6767	1.8	30.33	80.0	65.0				
	31.8	6307	1.7	28.27	78.6	65.0				
	34.6	5803	2.0	26.01	76.9	65.0				
	38.0	5278	2.1	23.66	80.0	65.0				
	42.0	4781	2.3	21.43	80.0	65.0				
	45.9	4375	2.6	19.61	80.0	65.0				
	50.9	3947	2.8	17.69	80.0	65.0				
	55.9	3590	2.9	16.09	80.0	65.0				
		12.4	15893	0.8	112.66	80.0				65.0
		13.7	14455	0.9	102.47	80.0	65.0			
		14.8	13380	1.0	94.85	80.0	65.0			
		16.2	12170	1.1	86.27	80.0	65.0			
		18.5	10659	1.2	75.56	80.0	65.0			
		20.4	9694	1.3	68.72	80.0	65.0			
		24.1	8183	1.6	58.01	80.0	65.0			
		26.5	7443	1.7	52.76	80.0	65.0			
		27.8	7097	1.8	50.31	80.0	65.0			
		31.6	6258	1.9	44.36	80.0	65.0			
		34.9	5653	2.2	40.07	80.0	65.0			
		37.9	5214	2.4	36.96	80.0	65.0			
		41.6	4743	2.5	33.62	80.0	65.0			
		46.2	4279	2.7	30.33	80.0	65.0			
		49.5	3988	2.6	28.27	78.6	65.0			
		53.8	3669	3.0	26.01	76.9	65.0			
		18.3	10299	1.0	152.74	80.0	65.0	K100390 180M2A	581	106
		20.4	9234	1.1	136.95	80.0	65.0			
		22.5	8399	1.2	124.56	80.0	65.0			
		24.9	7597	1.3	112.66	80.0	65.0			
		27.3	6910	1.4	102.47	80.0	65.0			
		29.5	6396	1.5	94.85	80.0	65.0			
		32.5	5817	1.7	86.27	80.0	65.0			
		37.1	5095	1.9	75.56	80.0	65.0			
		40.7	4634	2.1	68.72	80.0	65.0			
	48.3	3912	2.5	58.01	80.0	65.0				
	53.1	3558	2.8	52.76	80.0	65.0				
	55.7	3392	2.9	50.31	80.0	65.0				
	63.1	2991	3.0	44.36	80.0	65.0				
	21.0	9580	0.9	42.94	53.7	53.7	K90390 200L6C / 200L6D			
	22.6	8866	0.9	39.74	52.6	52.6				
	25.1	7998	1.1	35.85	51.3	51.3				
	36.7	5466	1.3	24.50	46.6	46.6				
	43.0	4674	1.5	20.95	44.7	44.7				
	47.6	4217	1.5	18.90	43.5	43.5				
	57.4	3500	1.5	15.69	41.3	41.3				
	62.8	3195	1.6	14.32	40.2	40.2				
	69.7	2882	1.6	12.92	39.0	39.0				
	84.0	2392	2.0	10.72	36.9	36.9				



P ₁ [kW]	n ₂ [Min ⁻¹]	M ₂ [Nm]	f _B	i _{ges}	FR (a) [kN]	FR (b) [kN]	Typ / Type / Tipo / Type / Tipo IE2 / IE3	 Kg ~	 mm
22.00	19.4	10179	0.8	72.16	62.0	62.0	K90390 180M4B / 180L4B	358	104
	21.6	9145	0.9	64.83	58.5	58.5			
	22.5	8776	0.9	62.21	58.0	58.0			
	23.9	8252	1.0	58.50	57.3	57.3			
	25.2	7822	1.0	55.45	56.8	56.8			
	27.1	7283	1.1	51.63	55.9	55.9			
	28.8	6849	1.2	48.55	55.1	55.1			
	32.6	6057	1.3	42.94	53.7	53.7			
	35.2	5606	1.4	39.74	52.6	52.6			
	39.1	5057	1.6	35.85	51.3	51.3			
	41.0	4822	1.7	34.18	50.8	50.8			
	45.4	4351	1.8	30.84	49.5	49.5			
	48.8	4050	2.0	28.71	48.6	48.6			
	54.7	3611	1.9	25.60	47.2	47.2			
	57.1	3456	1.9	24.50	46.6	46.6			
	66.8	2955	2.2	20.95	44.7	44.7			
	74.1	2666	2.3	18.90	43.5	43.5			
	89.2	2213	2.3	15.69	41.3	41.3			
	97.8	2020	2.5	14.32	40.2	40.2			
	108.4	1823	2.5	12.92	39.0	39.0			
130.6	1512	3.0	10.72	36.9	36.9				
	26.6	7092	0.9	105.17	62.0	65.0	K90390 180M2A	358	104
	29.5	6399	1.0	94.90	62.0	65.0			
	31.5	5992	1.0	88.87	62.0	65.0			
	32.7	5768	1.1	85.54	62.0	65.0			
	35.6	5311	1.1	78.76	62.0	63.0			
	38.8	4866	1.2	72.16	62.0	62.0			
	43.2	4371	1.4	64.83	58.5	58.5			
	45.0	4195	1.4	62.21	58.0	58.0			
	47.9	3945	1.5	58.50	57.3	57.3			
	50.5	3739	1.6	55.45	56.8	56.8			
	54.2	3481	1.7	51.63	55.9	55.9			
	57.7	3274	1.9	48.55	55.1	55.1			
	65.2	2895	2.1	42.94	53.7	53.7			
	70.5	2680	2.3	39.74	52.6	52.6			
	78.1	2417	2.5	35.85	51.3	51.3			
	81.9	2305	2.6	34.18	50.8	50.8			
	90.8	2080	2.9	30.84	49.5	49.5			
	109.4	1726	3.0	25.60	47.2	47.2			
	33.2	6044	0.8	27.09	24.9	24.9	K70390 200L6C / 200L6D	306	102
	36.1	5555	0.9	24.90	24.9	24.9			
	40.1	5004	0.9	22.43	24.8	24.8			
	44.1	4551	0.9	20.40	24.7	24.7			
	49.0	4101	0.9	18.38	24.5	24.5			
	53.6	3746	0.9	16.79	24.3	24.3			
	63.2	3175	1.0	14.23	23.8	23.8			
	77.3	2599	1.3	11.65	23.1	23.1			
	84.6	2374	1.3	10.64	22.8	22.8			
	32.1	6156	0.8	43.64	26.7	26.7	K70390 180M4B / 180L4B	248	102
	35.7	5540	0.9	39.27	27.0	27.0			
	38.7	5107	0.9	36.20	24.3	24.3			
	43.5	4540	1.0	32.18	24.6	24.6			
	47.2	4184	1.1	29.66	24.8	24.8			
	51.7	3822	1.2	27.09	24.9	24.9			
	56.2	3513	1.3	24.90	24.9	24.9			
	62.4	3164	1.4	22.43	24.8	24.8			
	68.6	2878	1.4	20.40	24.7	24.7			
	76.2	2593	1.4	18.38	24.5	24.5			
	83.4	2369	1.4	16.79	24.3	24.3			
	98.4	2007	1.5	14.23	23.8	23.8			
	120.2	1643	1.9	11.65	23.1	23.1			
	131.6	1501	2.0	10.64	22.8	22.8			



P ₁ [kW]	n ₂ [Min ⁻¹]	M ₂ [Nm]	f _B	i _{ges}	FR (a) [kN]	FR (b) [kN]	Typ / Type / Tipo / Type / Tipo IE2 / IE3	 ~	 mm					
22.00	40.2	4697	0.8	69.66	26.7	35.2	K70390 180M2A	248	102					
	44.2	4273	0.9	63.37	26.7	35.1								
	48.0	3932	1.0	58.32	26.7	29.8								
	51.9	3640	1.0	53.98	26.7	30.0								
	53.9	3501	1.1	51.92	26.7	30.0								
	58.6	3222	1.2	47.78	26.7	26.4								
	64.2	2943	1.2	43.64	26.7	26.7								
	71.3	2648	1.4	39.27	27.0	27.0								
	77.3	2441	1.5	36.20	24.3	24.3								
	87.0	2170	1.6	32.18	24.6	24.6								
	94.4	2000	1.8	29.66	24.8	24.8								
	103.4	1827	1.9	27.09	24.9	24.9								
	112.4	1679	2.1	24.90	24.9	24.9								
	124.8	1512	2.2	22.43	24.8	24.8								
	137.3	1376	2.2	20.40	24.7	24.7								
	152.3	1239	2.2	18.38	24.5	24.5								
	166.8	1132	2.1	16.79	24.3	24.3								
	196.8	960	2.5	14.23	23.8	23.8								
	240.3	786	3.0	11.65	23.1	23.1								
		53.2	3711	0.8	26.31	22.1	6.3	K60390 180M4B / 180L4B	206	100				
		60.2	3283	0.9	23.27	20.0	5.7							
		66.7	2962	0.8	21.00	22.3	6.4							
		74.0	2669	0.8	18.92	22.2	6.3							
		89.3	2211	1.0	15.67	20.4	5.8							
		98.9	1996	1.1	14.15	20.3	5.8							
		109.8	1799	1.1	12.75	20.2	5.8							
		132.6	1490	1.3	10.56	19.8	5.7							
		145.4	1358	1.3	9.63	19.6	5.6							
		175.7	1124	1.3	7.97	19.1	5.5							
			67.9	2782	0.8	41.26	22.1				8.8	K60390 180M2A	206	100
			79.4	2377	0.9	35.25	22.1				8.6			
			88.1	2142	1.0	31.77	22.1				7.1			
			89.2	2117	1.0	31.39	22.1				7.1			
			99.6	1895	1.1	28.11	22.1				7.1			
	106.4		1774	1.2	26.31	22.1	6.3							
120.3	1569		1.4	23.27	20.0	5.7								
133.3	1416		1.3	21.00	22.3	6.4								
148.0	1276		1.3	18.92	22.2	6.3								
178.7	1057		1.5	15.67	20.4	5.8								
197.9	954		1.7	14.15	20.3	5.8								
219.6	860		1.8	12.75	20.2	5.8								
265.2	712		2.1	10.56	19.8	5.7								
290.8	649		2.1	9.63	19.6	5.6								
351.3	537		2.1	7.97	19.1	5.5								
30.00	15.5	17648	0.8	58.01	80.0	65.0	K100390 225M6B / 225M6C	731	106					
	17.1	16051	0.9	52.76	80.0	65.0								
	17.9	15305	0.9	50.31	80.0	65.0								
	20.3	13495	0.9	44.36	80.0	65.0								
	22.5	12190	1.1	40.07	80.0	65.0								
	24.4	11244	1.1	36.96	80.0	65.0								
	26.8	10228	1.2	33.62	79.5	65.0								
	29.7	9227	1.3	30.33	77.5	65.0								
	31.8	8600	1.2	28.27	76.2	65.0								
	34.6	7913	1.5	26.01	74.6	65.0								
	38.0	7198	1.5	23.66	72.8	65.0								
	42.0	6519	1.7	21.43	71.0	65.0								
	45.9	5966	1.9	19.61	69.2	65.0								
	50.9	5382	2.0	17.69	80.0	65.0								
	55.9	4895	2.1	16.09	80.0	65.0								
	59.1	4630	2.3	15.22	80.0	64.5								
	65.2	4198	2.4	13.80	80.0	62.8								
	71.7	3818	2.4	12.55	80.0	61.1								
	77.3	3541	2.3	11.64	80.0	59.8								
		87.0	3146	2.6	10.34	80.0				57.0				
103.6		2644	2.7	8.69	80.0	54.2								

P ₁ [kW]	n ₂ [Min ⁻¹]	M ₂ [Nm]	f _B	i _{ges}	FR (a) [kN]	FR (b) [kN]	Typ / Type / Tipo / Type / Tipo IE2 / IE3	 Kg ~	 mm
30.00	16.2	16595	0.8	86.27	80.0	65.0	K100390 200L4C / 200L4D	649	106
	18.5	14535	0.9	75.56	80.0	65.0			
	20.4	13219	1.0	68.72	80.0	65.0			
	24.1	11159	1.2	58.01	80.0	65.0			
	26.5	10149	1.3	52.76	80.0	65.0			
	27.8	9678	1.3	50.31	80.0	65.0			
	31.6	8533	1.4	44.36	80.0	65.0			
	34.9	7708	1.6	40.07	80.0	65.0			
	37.9	7110	1.7	36.96	80.0	65.0			
	41.6	6467	1.8	33.62	79.5	65.0			
	46.2	5834	2.0	30.33	77.5	65.0			
	49.5	5438	1.9	28.27	76.2	65.0			
	53.8	5003	2.2	26.01	74.6	65.0			
	59.2	4551	2.3	23.66	72.8	65.0			
	65.3	4122	2.5	21.43	71.0	65.0			
71.4	3772	2.8	19.61	69.2	65.0				
	27.3	9422	1.0	102.47	80.0	65.0	K100390 200L2B / 200L2C	649	106
	29.5	8721	1.1	94.85	80.0	65.0			
	32.5	7932	1.2	86.27	80.0	65.0			
	37.1	6948	1.4	75.56	80.0	65.0			
	40.7	6319	1.6	68.72	80.0	65.0			
	48.3	5334	1.9	58.01	80.0	65.0			
	53.1	4851	2.0	52.76	80.0	65.0			
	55.7	4326	2.1	50.31	80.0	65.0			
	63.1	4079	2.2	44.36	80.0	65.0			
	69.9	3684	2.6	40.07	80.0	65.0			
	83.3	3091	2.9	33.62	79.5	65.0			
	99.0	2599	3.0	28.27	76.2	65.0			
	25.1	10906	0.8	35.85	48.8	48.8	K90390 225M6B / 225M6C	518	104
	36.7	7453	0.9	24.50	44.8	44.8			
	43.0	6373	1.1	20.95	43.2	43.2			
	47.6	5750	1.1	18.90	42.1	42.1			
	57.4	4773	1.1	15.69	40.2	40.2			
	62.8	4356	1.2	14.32	39.2	39.2			
	69.7	3931	1.2	12.92	38.1	38.1			
	84.0	3261	1.4	10.72	36.2	36.2			
	25.2	10667	0.8	55.45	56.8	56.8	K90390 200L4C / 200L4D	436	104
	32.6	8260	1.0	42.94	50.6	50.6			
	35.2	7645	1.0	39.74	49.8	49.8			
	39.1	6896	1.2	35.85	48.8	48.8			
	57.1	4713	1.4	24.50	44.8	44.8			
	66.8	4030	1.6	20.95	43.2	43.2			
	74.1	3636	1.7	18.90	42.1	42.1			
	89.2	3018	1.7	15.69	40.2	40.2			
	97.8	2755	1.8	14.32	39.2	39.2			
	108.4	2485	1.8	12.92	38.1	38.1			
	130.6	2062	2.2	10.72	36.2	36.2			
	35.6	7242	0.8	78.76	56.8	63.0	K90390 200L2B / 200L2C	436	104
	50.5	5099	1.2	55.45	56.8	56.8			
	65.2	3948	1.5	42.94	50.6	50.6			
	70.5	3654	1.7	39.74	49.8	49.8			
	78.1	3296	1.8	35.85	48.8	48.8			
	114.3	2253	2.3	24.50	44.8	44.8			
	133.7	1926	2.6	20.95	43.2	43.2			
	148.1	1738	2.6	18.90	42.1	42.1			
	178.5	1443	2.6	15.69	40.2	40.2			
	195.5	1317	2.9	14.32	39.2	39.2			
	216.7	1188	2.9	12.92	38.1	38.1			

P ₁ [kW]	n ₂ [Min ⁻¹]	M ₂ [Nm]	f _B	i _{ges}	FR (a) [kN]	FR (b) [kN]	Typ / Type / Tipo / Type / Tipo IE2 / IE3	 ~				
30.00	43.5	6190	0.8	32.18	24.6	24.6	K70390 200L4C / 200L4D	306	102			
	47.2	5706	0.8	29.66	24.8	24.8						
	51.7	5211	0.9	27.09	20.0	20.0						
	56.2	4790	1.0	24.90	20.4	20.4						
	62.4	4315	1.0	22.43	20.8	20.8						
	68.6	3924	1.0	20.40	21.0	21.0						
	76.2	3536	1.0	18.38	21.2	21.2						
	83.4	3230	1.0	16.79	21.3	21.3						
	98.4	2737	1.1	14.23	21.3	21.3						
	120.2	2241	1.4	11.65	21.0	21.0						
	131.6	2047	1.5	10.64	20.9	20.9						
	51.9	4963	0.8	53.98	24.6	30.0				K70390 200L2B / 200L2C	306	102
	53.9	4774	0.8	51.92	24.6	30.0						
	58.6	4393	0.9	47.78	24.6	26.4						
	64.2	4013	0.9	43.64	24.6	26.7						
	71.3	3611	1.0	39.27	24.6	27.0						
	77.3	3329	1.1	36.20	24.6	24.3						
	87.0	2959	1.2	32.18	24.6	24.6						
	94.4	2727	1.3	29.66	24.8	24.8						
	103.4	2491	1.4	27.09	20.0	20.0						
	112.4	2290	1.5	24.90	20.4	20.4						
	124.8	2062	1.6	22.43	20.8	20.8						
	137.3	1876	1.6	20.40	21.0	21.0						
	152.3	1690	1.6	18.38	21.2	21.2						
	166.8	1544	1.6	16.79	21.3	21.3						
	196.8	1308	1.8	14.23	21.3	21.3						
240.3	1071	2.2	11.65	21.0	21.0							
263.2	978	2.3	10.64	20.9	20.9							
37.00	20.4	16304	0.8	68.72	80.0	65.0	K100390 225M4A / 225M4B	731	106			
	24.1	13763	0.9	58.01	80.0	65.0						
	26.5	12517	1.0	52.76	80.0	65.0						
	27.8	11936	1.1	50.31	80.0	65.0						
	31.6	10524	1.1	44.36	80.0	65.0						
	34.9	9507	1.3	40.07	79.7	65.0						
	37.9	8769	1.4	36.96	78.5	65.0						
	41.6	7976	1.5	33.62	76.9	65.0						
	46.2	7196	1.6	30.33	75.2	65.0						
	49.5	6707	1.5	28.27	74.0	65.0						
	53.8	6171	1.8	26.01	72.6	65.0						
	59.2	5613	1.9	23.66	71.0	65.0						
	65.3	5084	2.0	21.43	69.3	65.0						
	71.4	4652	2.3	19.61	67.7	65.0						
	79.1	4197	2.5	17.69	65.9	65.0						
	87.0	3817	2.6	16.09	64.3	64.3						
	92.0	3611	2.8	15.22	63.4	63.4						
	101.4	3274	2.9	13.80	61.7	61.7						
	111.6	2977	3.0	12.55	60.1	60.1						
	120.3	2762	2.8	11.64	58.9	58.9						
	27.3	11621	0.9	102.47	80.0	65.0				K100390 200L2C / 200L2D	649	106
	29.5	10756	0.9	94.85	80.0	65.0						
	32.5	9783	1.0	86.27	80.0	65.0						
	37.1	8569	1.2	75.56	80.0	65.0						
	40.7	7793	1.3	68.72	80.0	65.0						
	48.3	6579	1.5	58.01	80.0	65.0						
	53.1	5983	1.7	52.76	80.0	65.0						
	55.7	5705	1.7	50.31	80.0	65.0						
	63.1	5031	1.8	44.36	80.0	65.0						
	69.9	4544	2.1	40.07	79.7	65.0						
	83.3	3813	2.4	33.62	76.9	65.0						
	92.3	3440	2.5	30.33	75.2	65.0						
	99.0	3206	2.4	28.27	74.0	65.0						
	107.7	2950	2.9	26.01	72.6	65.0						
118.3	2683	3.0	23.66	71.0	65.0							

P ₁ [kW]	n ₂ [Min ⁻¹]	M ₂ [Nm]	f _B	i _{ges}	FR (a) [kN]	FR (b) [kN]	Typ / Type / Tipo / Type / Tipo IE2 / IE3	 ~ Kg	 mm			
37.00	32.6	10187	0.8	42.94	50.6	50.6	K90390 225M4A / 225M4B	518	104			
	35.2	9428	0.8	39.74	47.4	47.4						
	39.1	8505	0.9	35.85	46.6	46.6						
	57.1	5813	1.2	24.50	43.3	43.3						
	66.8	4970	1.3	20.95	41.9	41.9						
	74.1	4484	1.3	18.90	41.0	41.0						
	89.2	3722	1.3	15.69	39.2	39.2						
	97.8	3397	1.5	14.32	38.3	38.3						
	108.4	3065	1.5	12.92	37.3	37.3						
	130.6	2543	1.8	10.72	35.5	35.5						
	50.5	6288	1.0	55.45	50.6	56.8				K90390 200L2C / 200L2D	436	104
	65.2	4870	1.2	42.94	50.6	50.6						
	70.5	4507	1.3	39.74	47.4	47.4						
	78.1	4066	1.5	35.85	46.6	46.6						
	114.3	2778	1.8	24.50	43.3	43.3						
	133.7	2376	2.1	20.95	41.9	41.9						
	148.1	2143	2.1	18.90	41.0	41.0						
	178.5	1779	2.1	15.69	39.2	39.2						
	195.5	1624	2.3	14.32	38.3	38.3						
	216.7	1465	2.3	12.92	37.3	37.3						
	261.2	1216	2.8	10.72	35.5	35.5						
	71.3	4453	0.8	39.27	24.6	27.0	K70390 200L2C / 200L2D	306	102			
	77.3	4105	0.9	36.20	24.6	24.3						
	87.0	3649	1.0	32.18	24.6	24.6						
	94.4	3364	1.1	29.66	24.6	24.8						
	103.4	3072	1.1	27.09	24.6	20.0						
	112.4	2824	1.2	24.90	24.6	20.4						
	124.8	2544	1.3	22.43	24.6	20.8						
	137.3	2313	1.3	20.40	24.6	21.0						
	152.3	2084	1.3	18.38	24.6	21.2						
	166.8	1904	1.3	16.79	24.6	21.3						
	196.8	1614	1.5	14.23	24.6	21.3						
	240.3	1321	1.8	11.65	24.6	21.0						
	263.2	1207	1.9	10.64	24.6	20.9						
	45.00	24.1	16739	0.8	58.01	80.0	65.0	K100390 225M4B / 225M4C	731	106		
		26.5	15224	0.9	52.76	80.0	65.0					
27.8		14517	0.9	50.31	78.7	65.0						
31.6		12800	0.9	44.36	77.4	65.0						
34.9		11562	1.1	40.07	76.2	65.0						
37.9		10665	1.2	36.96	75.2	65.0						
41.6		9701	1.2	33.62	74.0	65.0						
46.2		8752	1.3	30.33	72.5	65.0						
49.5		8157	1.3	28.27	71.5	65.0						
53.8		7505	1.5	26.01	70.3	65.0						
59.2		6827	1.5	23.66	68.9	65.0						
65.3		6184	1.7	21.43	67.4	65.0						
71.4		5658	1.9	19.61	66.0	65.0						
79.1		5104	2.0	17.69	64.4	64.4						
87.0		4643	2.1	16.09	62.9	62.9						
92.0		4392	2.3	15.22	62.0	62.0						
101.4		3982	2.4	13.80	60.5	60.5						
111.6		3621	2.4	12.55	59.0	59.0						
120.3		3359	2.3	11.64	57.8	57.8						
135.4		2984	2.6	10.34	56.1	56.1						
161.1		2507	2.7	8.69	53.4	53.4						
40.7		9478	1.0	68.72	80.0	65.0	K100390 225M2B				731	106
48.3		8001	1.2	58.01	80.0	65.0						
53.1		7277	1.4	52.76	80.0	65.0						
55.7		6939	1.4	50.31	78.7	65.0						
63.1		6118	1.5	44.36	77.4	65.0						
69.9		5527	1.7	40.07	76.2	65.0						
83.3		4637	2.0	33.62	74.0	65.0						
92.3		4183	2.1	30.33	72.5	65.0						
99.0		3899	2.0	28.27	71.5	65.0						
107.7		3587	2.4	26.01	70.3	65.0						
118.3		3263	2.4	23.66	68.9	65.0						
130.7		2956	2.7	21.43	67.4	65.0						
142.8		2705	3.0	19.61	66.0	65.0						

P ₁ [kW]	n ₂ [Min ⁻¹]	M ₂ [Nm]	f _B	i _{ges}	FR (a) [kN]	FR (b) [kN]	Typ / Type / Tipo / Type / Tipo IE2 / IE3	 ~				
45.00	39.1	10344	0.8	35.85	46.6	46.6	K90390 225M4B / 225M4C	518	104			
	57.1	7069	0.9	24.50	41.6	41.6						
	66.8	6045	1.1	20.95	40.5	40.5						
	74.1	5454	1.1	18.90	39.6	39.6						
	89.2	4527	1.1	15.69	38.1	38.1						
	97.8	4132	1.2	14.32	37.3	37.3						
	108.4	3728	1.2	12.92	36.4	36.4						
	130.6	3093	1.5	10.72	34.7	34.7						
	47.9	8069	0.8	55.45	46.6	57.3						
	65.2	5922	1.0	42.94	46.6	50.6						
	70.5	5481	1.1	39.74	46.6	47.4						
	78.1	4945	1.2	35.85	46.6	46.6						
	114.3	3379	1.5	24.50	41.6	41.6						
	133.7	2890	1.7	20.95	40.5	40.5						
	148.1	2607	1.7	18.90	39.6	39.6						
	178.5	2164	1.8	15.69	38.1	38.1						
195.5	1975	1.9	14.32	37.3	37.3							
216.7	1782	1.9	12.92	36.4	36.4							
261.2	1479	2.3	10.72	34.7	34.7							
55.00	31.6	15644	0.8	44.36	77.4	65.0	K100390 250M4A / 250M4B	1085	106			
	34.9	14131	0.9	40.07	71.8	65.0						
	37.9	13035	0.9	36.96	71.2	65.0						
	41.6	11857	1.0	33.62	70.3	65.0						
	46.2	10696	1.1	30.33	69.2	65.0						
	49.5	9970	1.0	28.27	68.4	65.0						
	53.8	9173	1.2	26.01	67.5	65.0						
	59.2	8344	1.3	23.66	66.3	65.0						
	65.3	7558	1.4	21.43	65.1	65.0						
	71.4	6916	1.5	19.61	63.8	63.8						
	79.1	6239	1.7	17.69	62.4	62.4						
	87.0	5674	1.7	16.09	61.1	61.1						
	92.0	5368	1.9	15.22	60.4	60.4						
	101.4	4867	2.0	13.80	59.0	59.0						
	111.6	4426	2.0	12.55	57.6	57.6						
	120.3	4105	1.9	11.64	56.6	56.6						
	135.4	3647	2.2	10.34	54.9	54.9						
	161.1	3065	2.2	8.69	52.5	52.5						
	48.3	9779	1.0	58.01	77.4	65.0						
	53.1	8894	1.1	52.76	77.4	65.0						
	63.1	7478	1.2	44.36	77.4	65.0						
	69.9	6755	1.4	40.07	71.8	65.0						
	83.3	5667	1.6	33.62	70.3	65.0						
	92.3	5113	1.7	30.33	69.2	65.0						
	99.0	4766	1.6	28.27	68.4	65.0						
	107.7	4385	1.9	26.01	67.5	65.0						
	118.3	3988	2.0	23.66	66.3	65.0						
	130.7	3613	2.2	21.43	65.1	65.0						
	142.8	3306	2.5	19.61	63.8	63.8						
	158.3	2982	2.7	17.69	62.4	62.4						
	174.0	2712	2.8	16.09	61.1	61.1						
	184.0	2566	3.0	15.22	60.4	60.4						
240.5	1962	3.0	11.64	56.6	56.6							
75.00	46.2	14586	0.8	30.33	69.2	69.2	K100390 280M4B / 280M4C	1125	106			
	53.8	12508	0.9	26.01	61.8	61.8						
	59.2	11378	0.9	23.66	61.1	61.1						
	65.3	10306	1.0	21.43	60.4	60.4						
	79.1	8507	1.2	17.69	58.6	58.6						
	87.0	7738	1.3	16.09	57.6	57.6						
	92.0	7319	1.4	15.22	57.0	57.0						
	101.4	6637	1.4	13.80	56.0	56.0						
	111.6	6035	1.5	12.55	54.9	54.9						
	120.3	5598	1.4	11.64	54.0	54.0						
	135.4	4973	1.6	10.34	52.7	52.7						
	161.1	4179	1.6	8.69	50.6	50.6						

P ₁ [kW]	n ₂ [Min ⁻¹]	M ₂ [Nm]	f _B	i _{ges}	FR (a) [kN]	FR (b) [kN]	Typ / Type / Tipo / Type / Tipo IE2 / IE3	 Kg ~	 mm				
75.00	92.3	6972	1.3	30.33	65.0	65.0	K100390 280M2B / 280M2C	1035	106				
	107.7	5979	1.4	26.01	63.9	63.8							
	118.3	5439	1.5	23.66	62.4	62.4							
	130.7	4926	1.6	21.43	60.0	60.4							
	158.3	4066	1.9	17.69	55.1	56.0							
	174.0	3699	2.0	16.09	53.7	53.4							
	184.0	3499	2.2	15.22	52.3	52.5							
	202.9	3172	2.3	13.80	50.8	50.6							
	223.1	2885	2.3	12.55	50.1	50.6							
	240.5	2676	2.2	11.64	50.4	50.6							
	270.8	2377	2.5	10.34	47.6	49.2							
	322.2	1998	2.6	8.69	46.1	49.2							
	90.00	59.2	13654	0.8	23.66	-				61.1	K100390 280M4C / 280M4D	1125	106
		65.3	12367	0.8	21.43	-				60.4			
79.1		10209	1.0	17.69	55.7	55.7							
87.0		9285	1.1	16.09	55.0	55.0							
92.0		8783	1.1	15.22	54.5	54.5							
101.4		7964	1.2	13.80	53.7	53.7							
111.6		7243	1.2	12.55	52.8	52.8							
120.3		6717	1.1	11.64	52.1	52.1							
135.4		5967	1.3	10.34	51.0	51.0							
161.1		5015	1.4	8.69	49.2	49.2							
92.3		8366	1.0	30.33	62.4	62.4	K100390 280M2C / 280M2D	1035	106				
107.7		7175	1.2	26.01	62.4	62.4							
118.3		6527	1.2	23.66	62.4	62.4							
130.7		5911	1.3	21.43	60.0	60.4							
158.3		4880	1.6	17.69	55.1	55.0							
174.0		4438	1.7	16.09	53.7	53.7							
184.0		4198	1.8	15.22	52.3	52.8							
202.9		3807	1.9	13.80	50.8	50.6							
223.1		3462	1.9	12.55	50.1	50.6							
240.5		3211	1.8	11.64	50.4	50.6							
270.8	2852	2.1	10.34	47.6	49.2								
322.2	2397	2.2	8.69	46.1	49.2								

Maßtabellen

Dimension Tables

Dimensione Tabelle

Tables de Dimension

Tablas de Dimensiones

K...
35390 - 100390

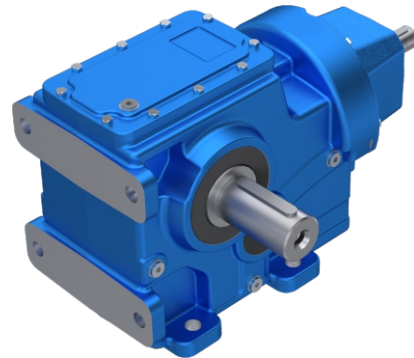
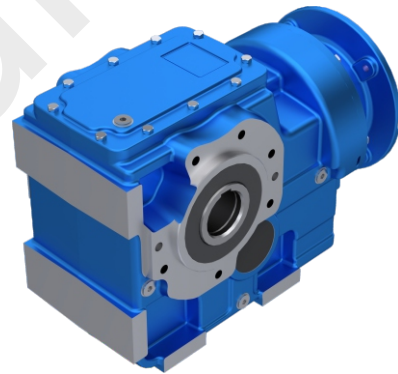
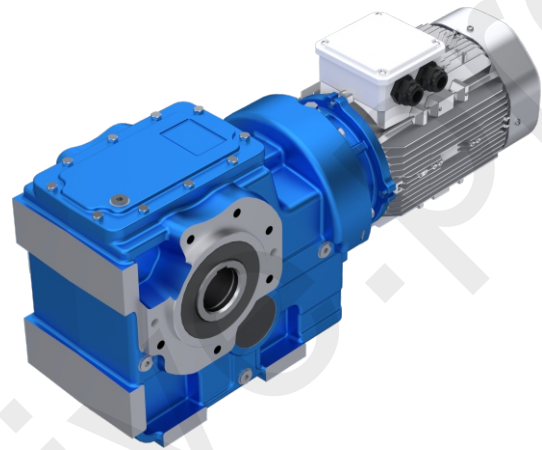

K...

K 35390

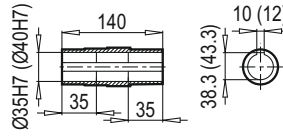
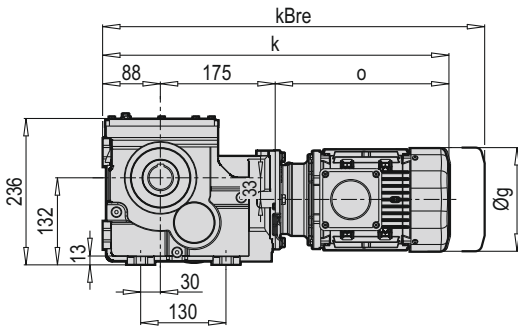

DA

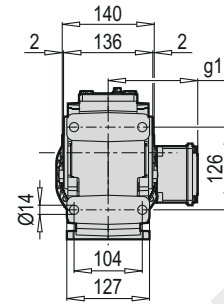

K 35390

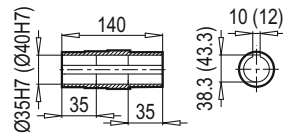
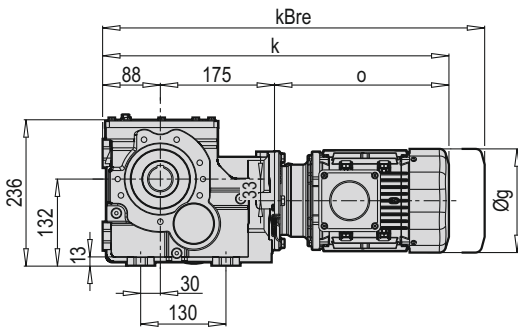

DA / B14

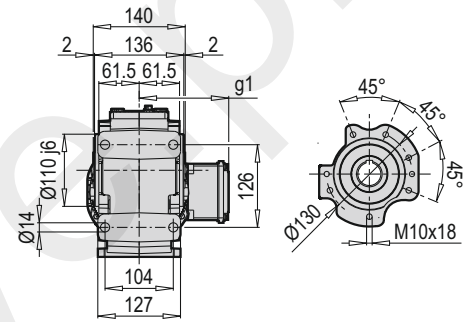

K 35390

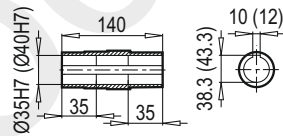
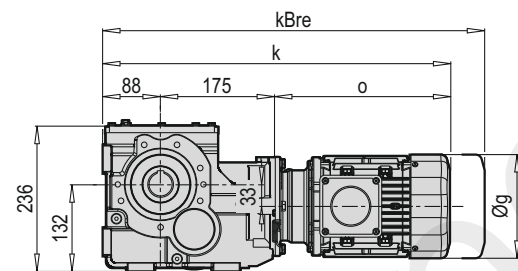

DG / B14

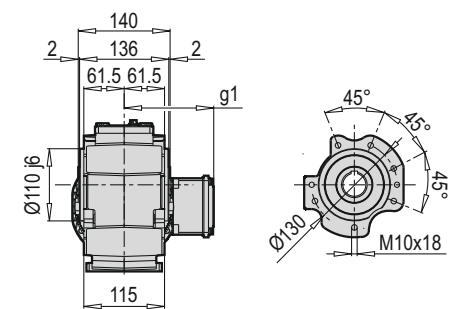

TMG / B5

DG / B5

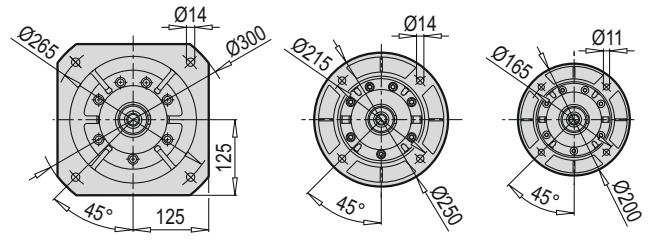
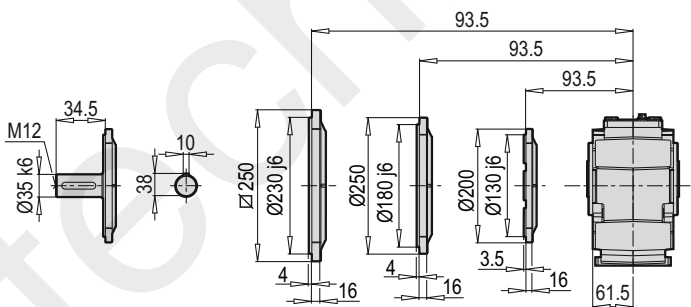

FA

FB

FC

FA

FB

FC

	80 M	90 L	100 L	112 M			
g	172	182	202	220			
g1	131	130	153	159			
k	528	611	642	646			
kBre	599	679	725	746			
o	265	348	379	383			

TMA / ÇMA

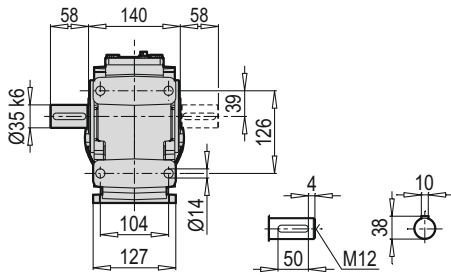

TMA / ÇMA / B14

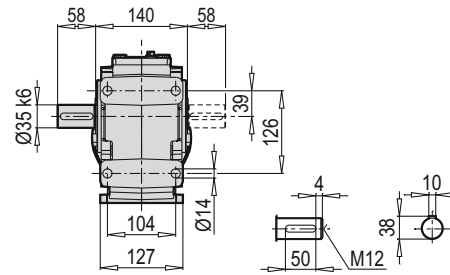

TMG / ÇMG / B14

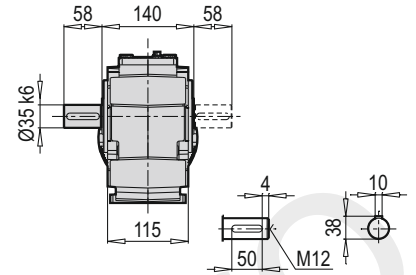

K 35390 DA PAM B5/B14

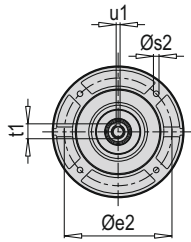
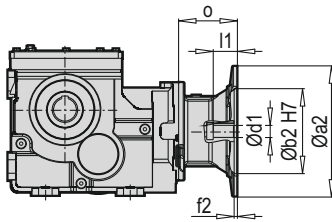

K 35390 DA W

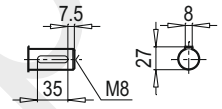
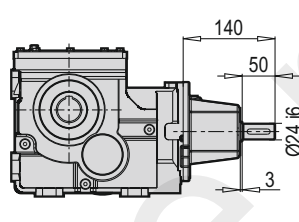

K 35390 DA/B14 PAM B5/B14

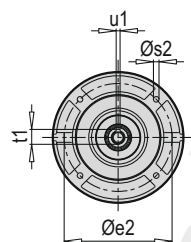
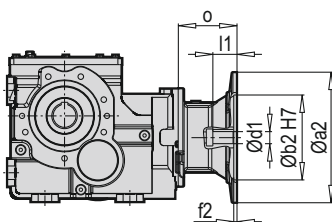

K 35390 DA/B14 W

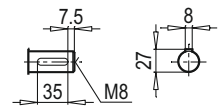
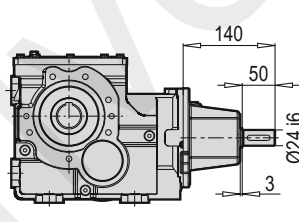

K 35390 DG/B14 PAM B5/B14

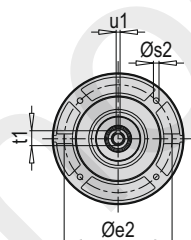
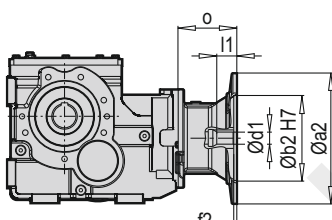

K 35390 DG/B14 W

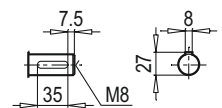
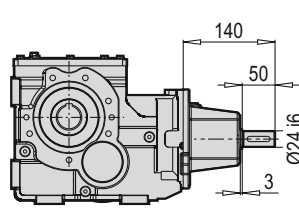

W ~ Kg	
K 35390	24

Typ / Type / Tipo Type / Tipo	PAM B5	Øa2	Øb2	Øe2	f2	Øs2	Ød1	l1	t1	u1	o
K 35390	63	140	95	115	4.5	8	11	25	12.8	4	57
	71	160	110	130	5	8	14	32	16.3	5	69
	80	200	130	165	5	10	19	42	21.8	6	90
	90	200	130	165	5	10	24	52	27.3	8	90
	100	250	180	215	5.5	12	28	62	31.3	8	105
	112	250	180	215	5.5	12	28	62	31.3	8	105

~ Kg	
PAM B5	K 35390
63	21
71	22
80	23
90	23
100	27
112	27

Typ / Type / Tipo Type / Tipo	PAM B14	Øa2	Øb2	Øe2	f2	Øs2	Ød1	l1	t1	u1	o
K 35390	63	90	60	75	2.5	6	11	25	12.8	4	57
	71	105	70	85	2.5	7	14	32	16.3	5	69
	80	120	80	100	3	7	19	42	21.8	6	90
	90	140	95	115	3	9	24	52	27.3	8	90
	100	160	110	130	3.5	9	28	62	31.3	8	105
	112	160	110	130	3.5	9	28	62	31.3	8	105

~ Kg	
PAM B14	K 35390
63	20
71	21
80	22
90	22
100	24
112	24

K 40390

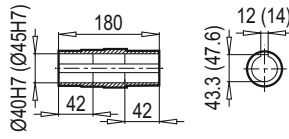
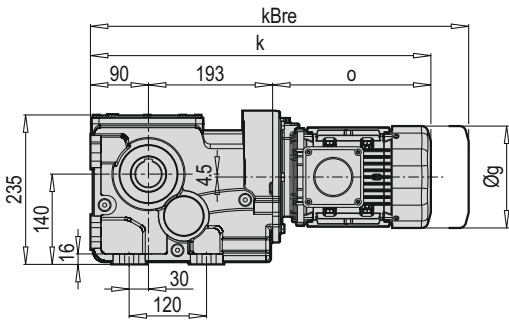

DA

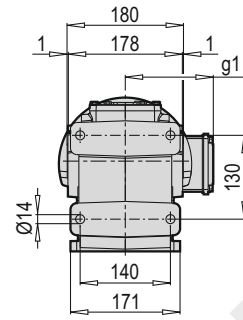

K 40390

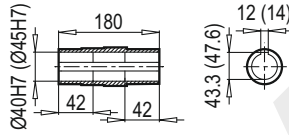
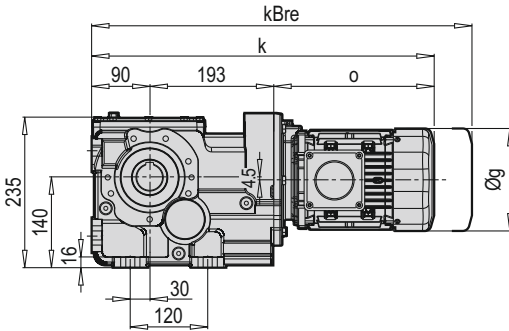

DA / B14

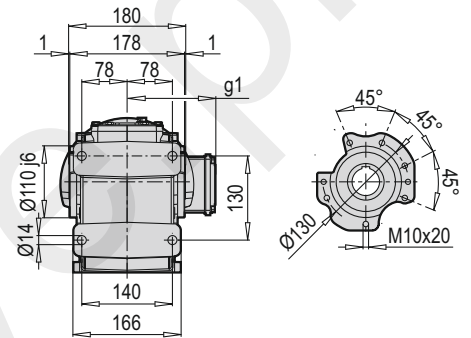

K 40390

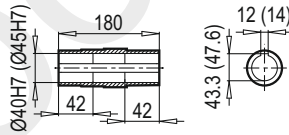
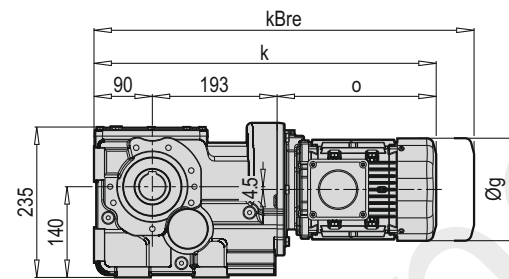

DG / B14

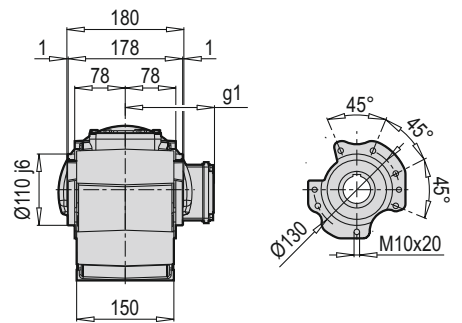

TMG / B5

DG / B5

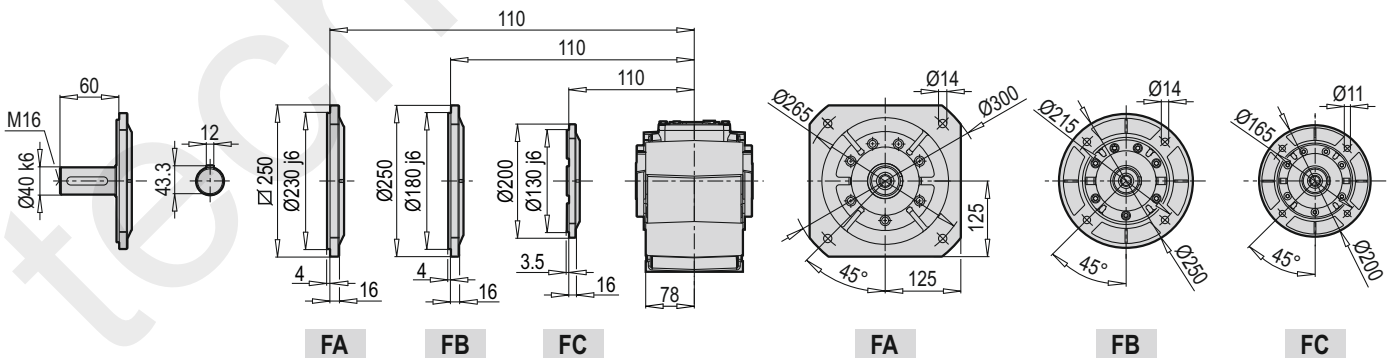

FA

FB

FC

FA

FB

FC

	80 M	90 L	100 L	112 M	132 S	132 M			
g	172	182	202	220	271	271			
g1	131	130	153	159	188	188			
k	529	612	665	663	737	737			
kBre	600	680	749	764	836	856			
o	246	329	382	380	454	454			

TMA - ÇMA

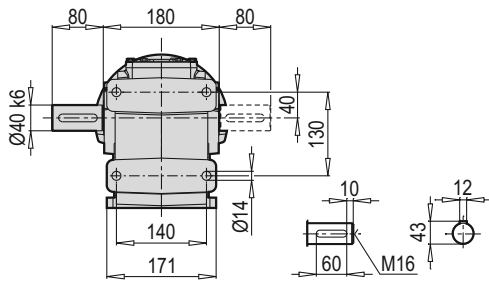

TMA - ÇMA / B14

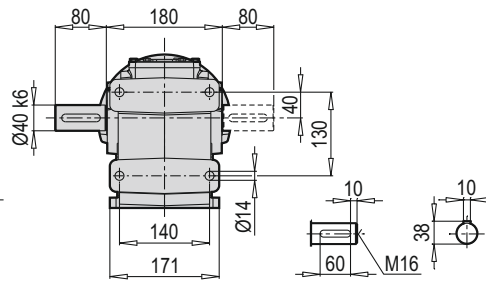

TMG - ÇMG / B14

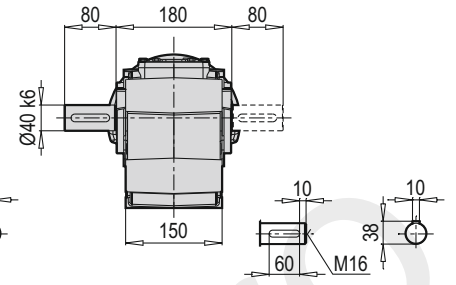

K 40390 DA PAM B5/B14

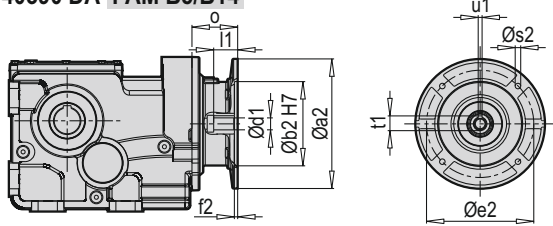

K 40390 DA W

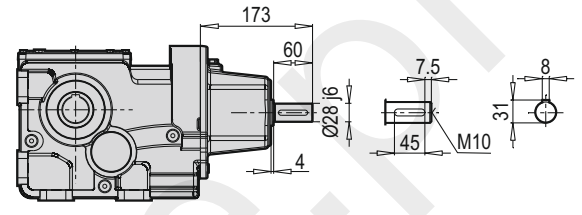

K 40390 DA/B14 PAM B5/B14

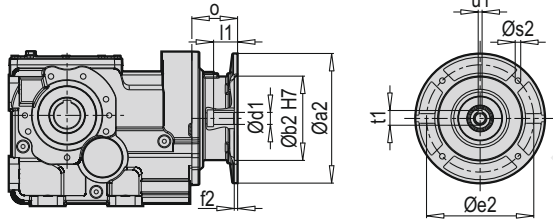

K 40390 DA/B14 W

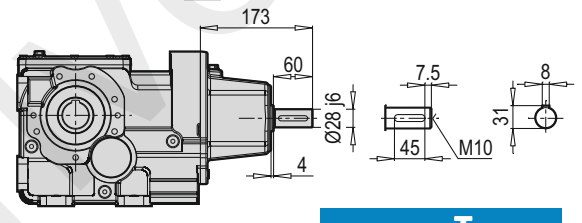

K 40390 DG/B14 PAM B5/B14

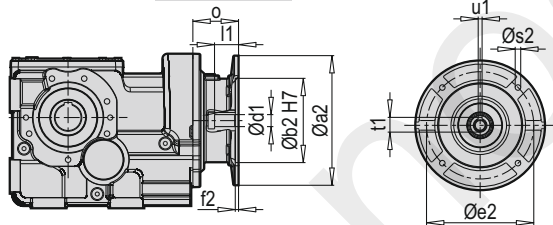

K 40390 DG/B14 W

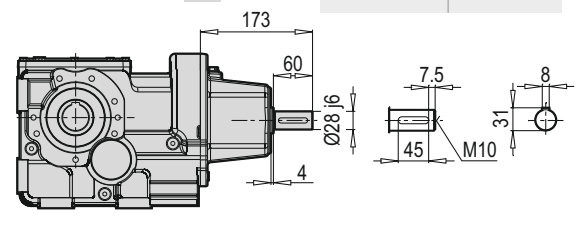

W ~ Kg	
K40390	35

Typ / Type / Tipo	PAM B5	Øa2	Øb2	Øe2	f2	Øs2	Ød1	l1	t1	u1	o
K 40390	80	200	130	165	5	10	19	42	21.8	6	70
	90	200	130	165	5	10	24	52	27.3	8	70
	100	250	180	215	5.5	12	28	62	31.3	8	85
	112	250	180	215	5.5	12	28	62	41.3	8	85
	132	300	230	265	5.5	12	38	82	31.3	10	110

~ Kg	
PAM B5	K 40390
80	33
90	33
100	35
112	35
132	39

Typ / Type / Tipo	PAM B14	Øa2	Øb2	Øe2	f2	Øs2	Ød1	l1	t1	u1	o
K40390	80	120	80	100	3	7	19	42	21.8	6	70
	90	140	95	115	3	9	24	52	27.3	8	70
	100	160	110	130	3.5	9	28	62	31.3	8	85
	112	160	110	130	3.5	9	28	62	31.3	8	85
	132	200	130	165	3.5	11	38	82	41.3	10	110

~ Kg	
PAM B14	K 40390
80	29
90	29
100	31
112	31
132	36

K 50390

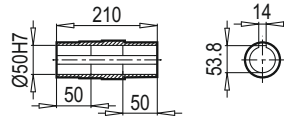
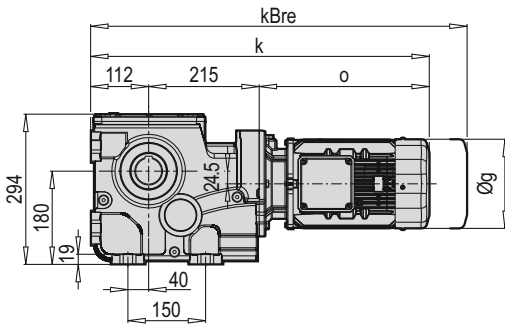

DA

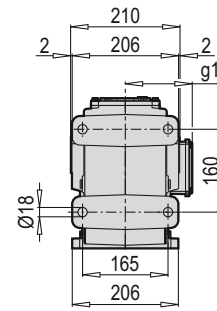

K 50390

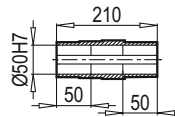
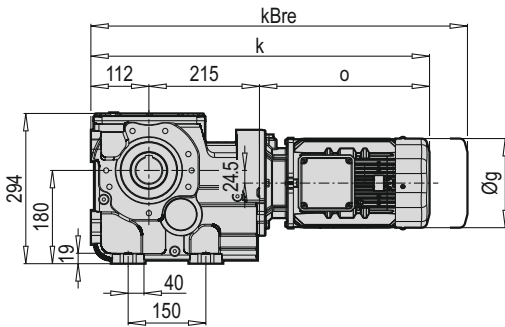

DA / B14

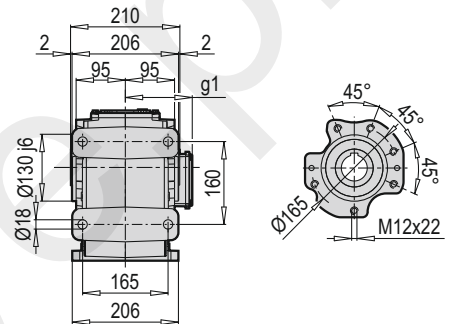

K 50390

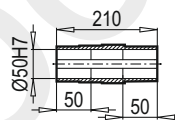
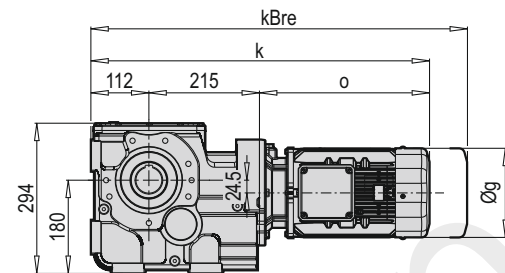

DG / B14

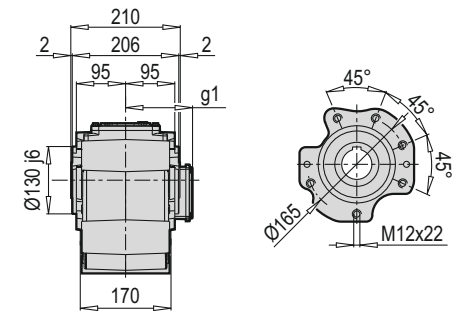

TMG / B5

DG / B5

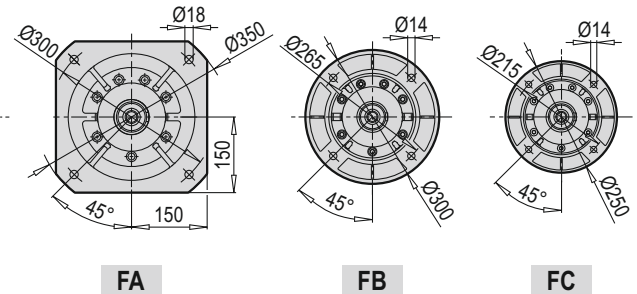
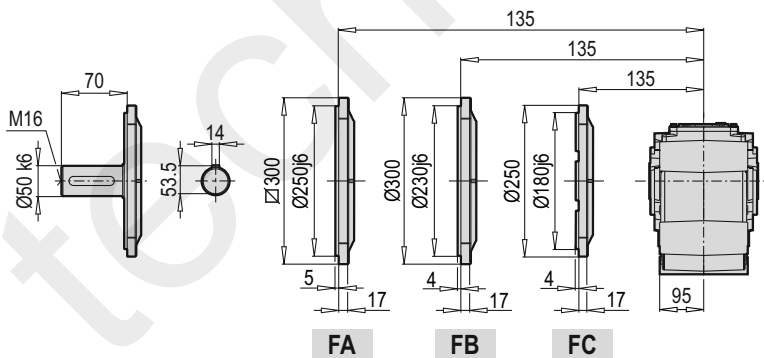

	80 M	90 L	100 L	112 M	132 S	132 M	160 M/L		
g	172	182	202	220	271	271	322		
g1	131	130	153	159	188	188	214		
k	573	656	709	707	781	781	862		
kBre	644	724	793	808	880	900	966		
o	246	329	382	380	454	454	535		

TMA - ÇMA

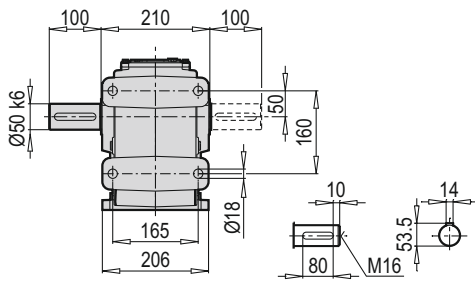

TMA - ÇMA / B14

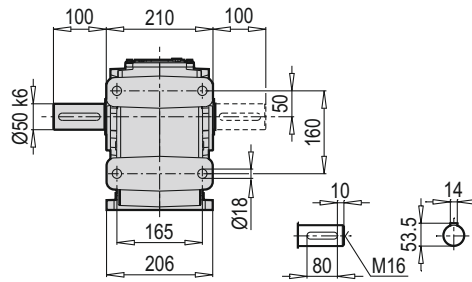

TMG - ÇMG / B14

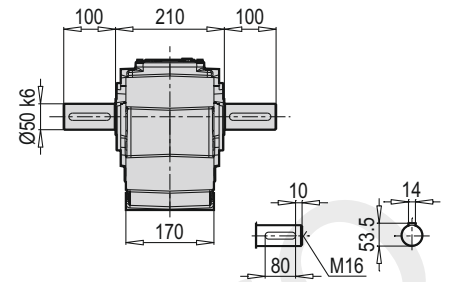

K 50390 DA PAM B5/B14

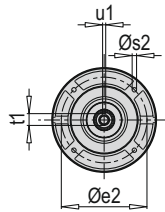
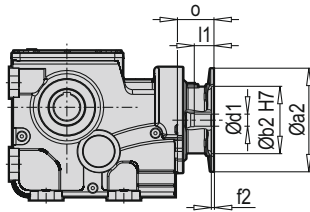

K 50390 DA W

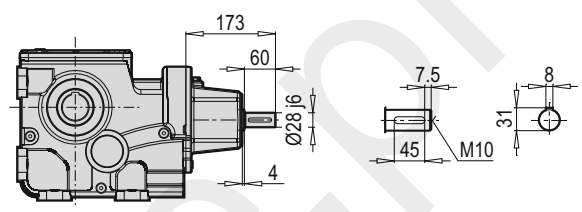

K 50390 DA/B14 PAM B5/B14

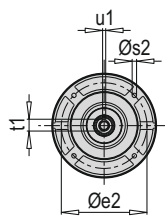
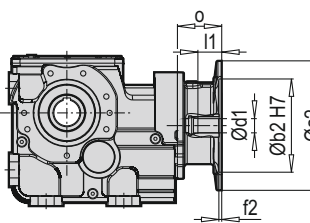

K 50390 DA/B14 W

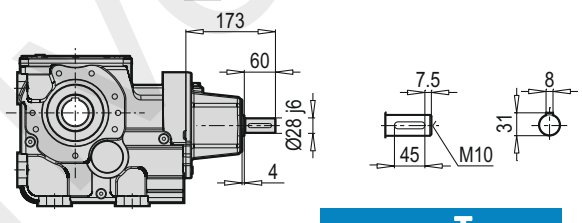

K 50390 DG/B14 PAM B5/B14

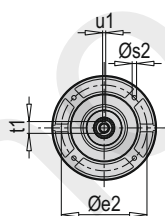
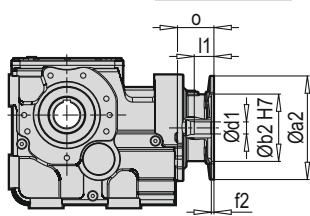

K 50390 DG/B14 W

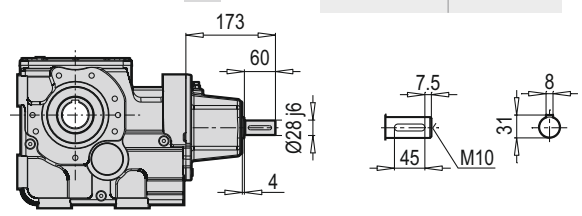

W ~ Kg	
K 50390	61

Typ / Type / Tipo	PAM B5	Øa2	Øb2	Øe2	f2	Øs2	Ød1	l1	t1	u1	o
K 50390	80	200	130	165	5	10	19	42	21.8	6	70
	90	200	130	165	5	10	24	52	27.3	8	70
	100	250	180	215	5.5	12	28	62	31.3	8	85
	112	250	180	215	5.5	12	28	62	31.3	8	85
	132	300	230	265	5.5	12	38	82	41.3	10	110
	160	350	250	300	7	16	42	112	45.3	12	158

~ Kg	
PAM B5	K 50390
80	59
90	59
100	61
112	61
132	65
160	72

Typ / Type / Tipo	PAM B14	Øa2	Øb2	Øe2	f2	Øs2	Ød1	l1	t1	u1	o
K 50390	80	120	80	100	3	7	19	42	21.8	6	70
	90	140	95	115	3	9	24	52	27.3	8	70
	100	160	110	130	3.5	9	28	62	31.3	8	85
	112	160	110	130	3.5	9	28	62	31.3	8	85
	132	200	130	165	3.5	11	38	82	41.3	10	110

~ Kg	
PAM B14	K 50390
80	55
90	55
100	57
112	57
132	62

K 60390

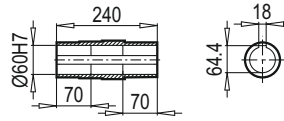
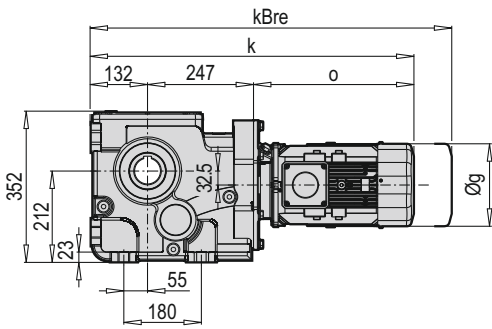

DA

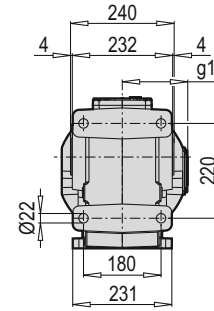

K 60390

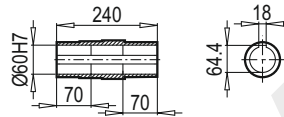
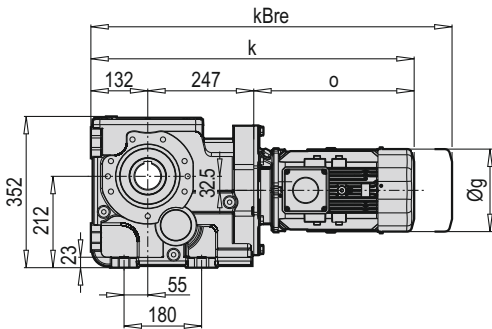

DA / B14

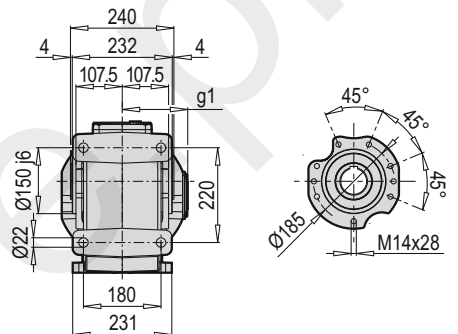

K 60390

DG / B14

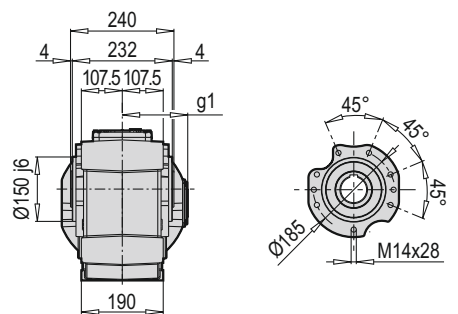
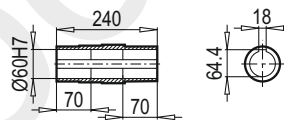
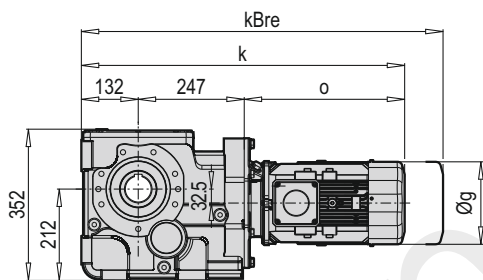

TMG / B5

DG / B5

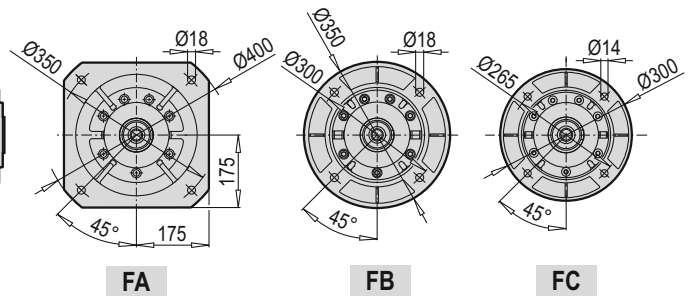
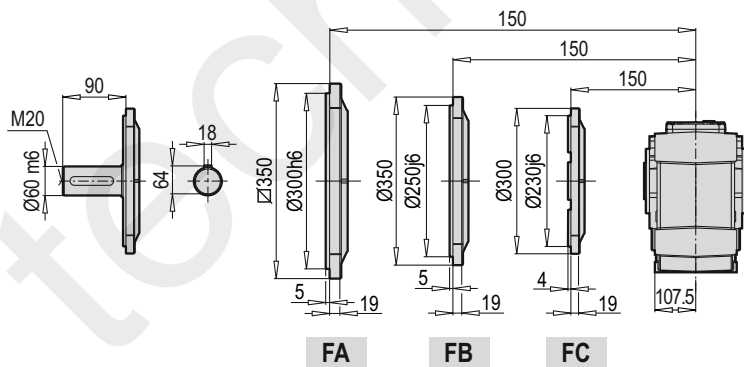

	90 L	100 L	112 M	132 S	132 M	160 M/L	180 M/L		
g	182	202	220	271	271	322	363		
g1	130	153	159	188	188	214	249		
k	698	752	750	823	823	904	994		
kBre	766	835	850	923	943	1009	1113		
o	319	373	371	444	444	525	615		

TMA - ÇMA

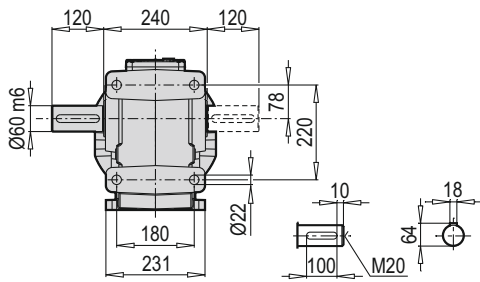

TMA - ÇMA / B14

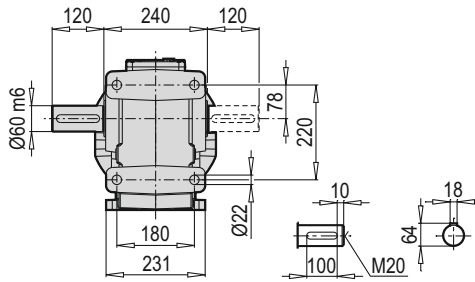

TMG - ÇMG / B14

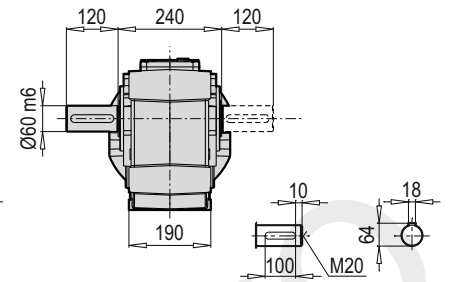

K 60390 DA PAM B5/B14

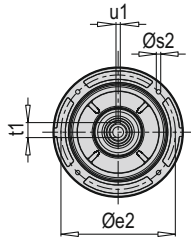
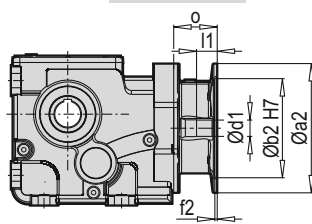

K 60390 DA W

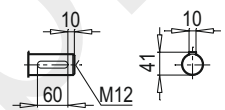
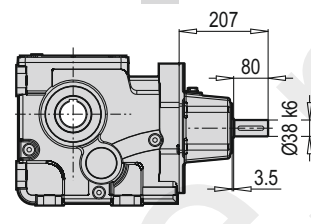

K 60390 DA/B14 PAM B5/B14

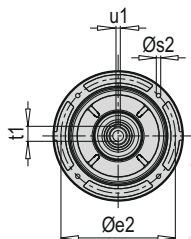
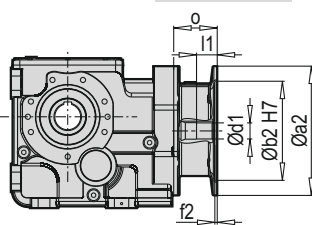

K 60390 DA/B14 W

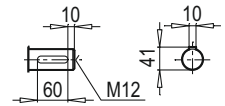
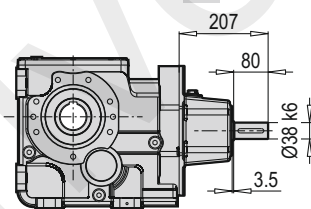

K 60390 DG/B14 PAM B5/B14

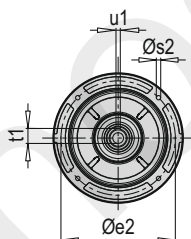
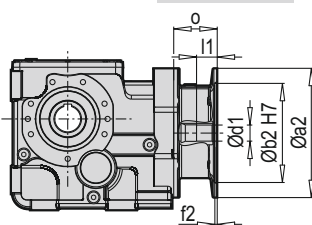

K 60390 DG/B14 W

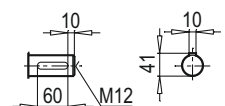
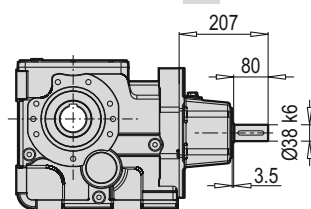

W ~ Kg	
K 60390	89

Typ / Type / Tipo	PAM B5	Øa2	Øb2	Øe2	f2	Øs2	Ød1	l1	t1	u1	o
K 60390	90	200	130	165	5	10	24	52	27.3	8	61
	100	250	180	215	5.5	12	28	62	31.3	8	76
	112	250	180	215	5.5	12	28	62	31.3	8	76
	132	300	230	265	5.5	12	38	82	41.3	10	101
	160	350	250	300	7	16	42	112	45.3	12	148
	180	350	250	300	7	16	48	112	51.8	14	148

~ Kg	
PAM B5	K 60390
90	80
100	84
112	84
132	87
160	93
180	93

Typ / Type / Tipo	PAM B14	Øa2	Øb2	Øe2	f2	Øs2	Ød1	l1	t1	u1	o
K 60390	90	140	95	115	3	9	24	52	27.3	8	61
	100	160	110	130	3.5	9	28	62	31.3	8	76
	112	160	110	130	3.5	9	28	62	31.3	8	76
	132	200	130	165	3.5	11	38	82	41.3	10	101

~ Kg	
PAM B14	K 60390
90	77
100	79
112	79
132	85

K 70390

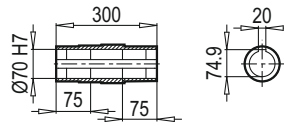
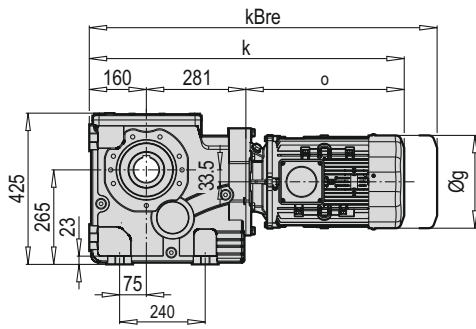

DA / B14

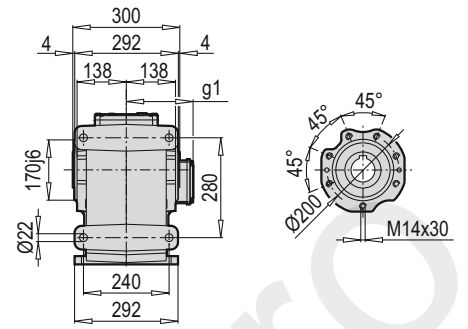

TMG / B5

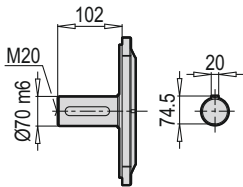

DG / B5

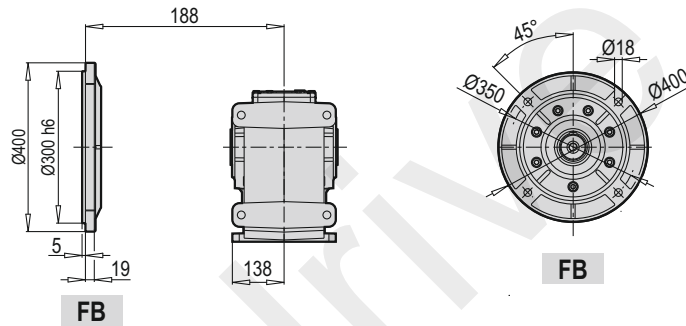

FB

FB

	100 L	112 M	132 S	132 M	160 M/L	180 M/L	200 L		
g	202	220	271	271	322	363	363		
g1	153	159	188	188	214	249	249		
k	814	812	885	885	966	1056	1056		
kBre	897	912	985	1005	1071	1175	1175		
o	373	371	444	444	525	615	615		

TMA - ÇMA / B14

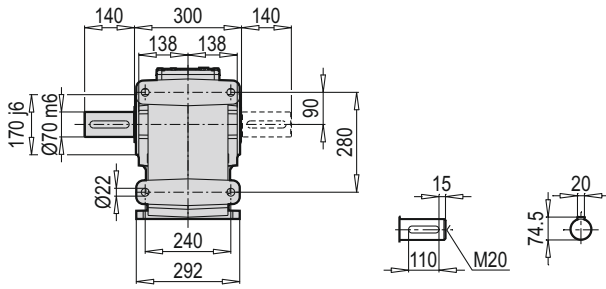

K 70390 DA/B14 PAM B5/B14

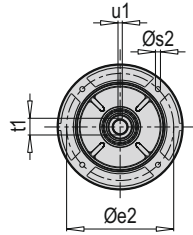
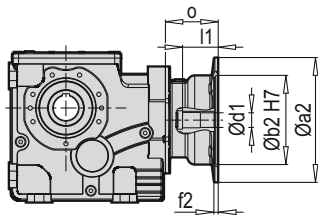

K 70390 DA/B14 W

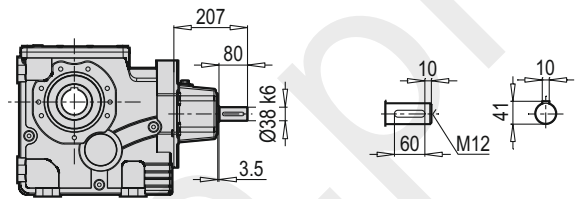

W ~ Kg	
K 70390	134.5

Typ / Type / Tipo Type / Tipo	PAM B5	Øa2	Øb2	Øe2	f2	Øs2	Ød1	l1	t1	u1	o
K 70390	100	250	180	215	5.5	12	28	62	31.3	8	76
	112	250	180	215	5.5	12	28	62	31.3	8	76
	132	300	230	265	5.5	12	38	82	41.3	10	101
	160	350	250	300	7	16	42	112	45.3	12	148
	180	350	250	300	7	16	48	112	51.8	14	148
	200	400	300	350	7	16	55	112	59.3	16	185

~ Kg	
PAM B5	K 70390
100	129.5
112	129.5
132	132.5
160	138.5
180	138.5
200	154.5

Typ / Type / Tipo Type / Tipo	PAM B14	Øa2	Øb2	Øe2	f2	Øs2	Ød1	l1	t1	u1	o
K 70390	100	160	110	130	3.5	9	28	62	31.3	8	76
	112	160	110	130	3.5	9	28	62	31.3	8	76
	132	200	130	165	3.5	11	38	82	41.3	10	101

~ Kg	
PAM B14	K 70390
100	125
112	125
132	131

K 90390

DA / B14

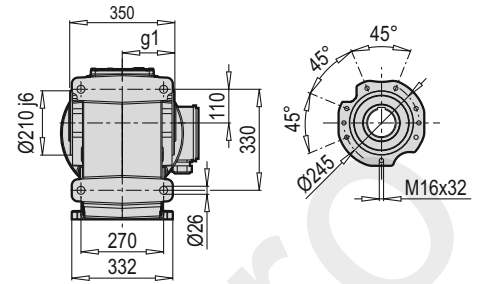
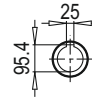
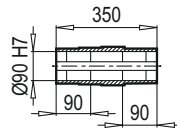
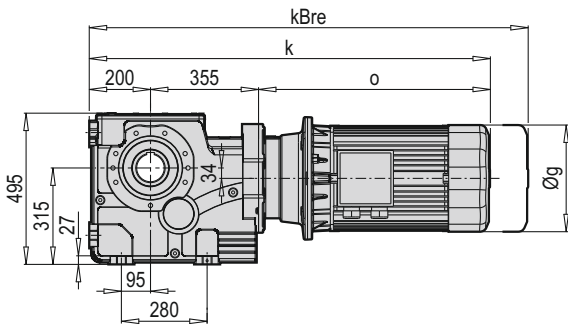

TMA / B5

DG / B5

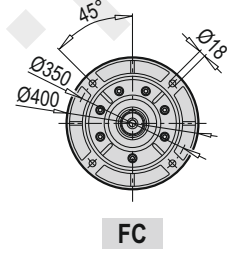
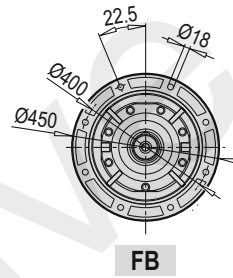
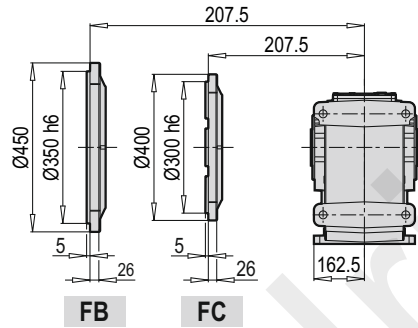
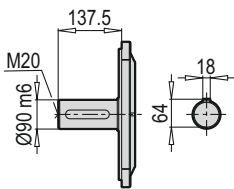

	132 S	132 M	160 M/L	180 M/L	200 L	225			
g	271	271	322	363	363	456			
g1	188	188	214	249	249	260			
k	1030	1030	1157	1262	1309	1339			
kBre	1130	1150	1262	1381	1427	1473			
o	477	477	604	709	756	786			

TMA - ÇMA / B14

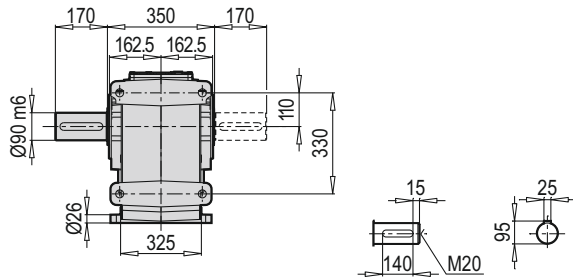

K 90390 DA/B14 PAM B5/B14

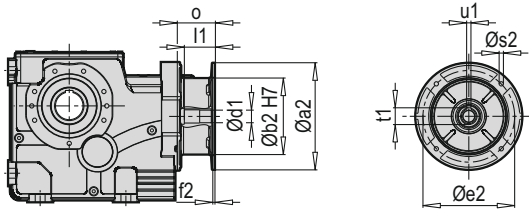

K 90390 DA/B14 W

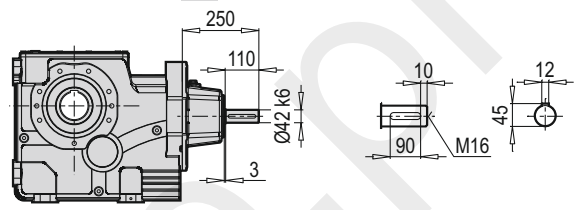

W ~ Kg	
K 90390	216.5

Typ / Type / Tipo Type / Tipo	PAM B5	Øa2	Øb2	Øe2	f2	Øs2	Ød1	l1	t1	u1	o
160	350	250	300	7	16	42	112	45.3	12	124	
180	350	250	300	7	16	48	112	51.8	14	124	
200	400	300	350	7	16	55	112	59.3	16	161	
225	450	350	400	7	16	60	142	64.4	18	161	

~ Kg	
PAM B5	K 90390
132	203.5
160	211.5
180	211.5
200	226.5
225	229.5

Typ / Type / Tipo Type / Tipo	PAM B14	Øa2	Øb2	Øe2	f2	Øs2	Ød1	l1	t1	u1	o

~ Kg	
PAM B14	K 90390
132	197

K 100390

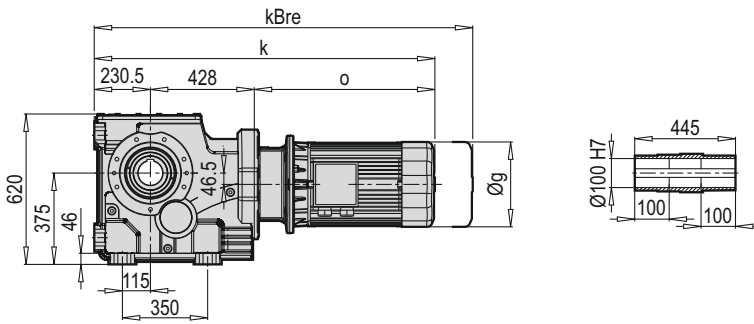

DA / B14

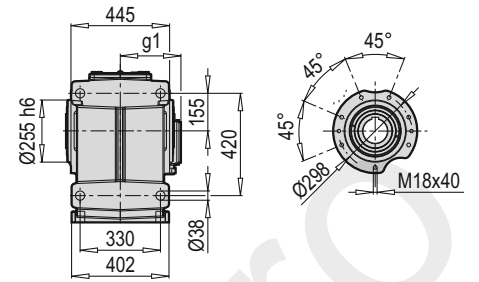

TMA / B5

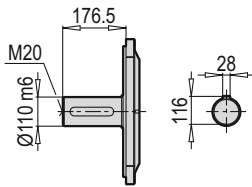

DA / B5

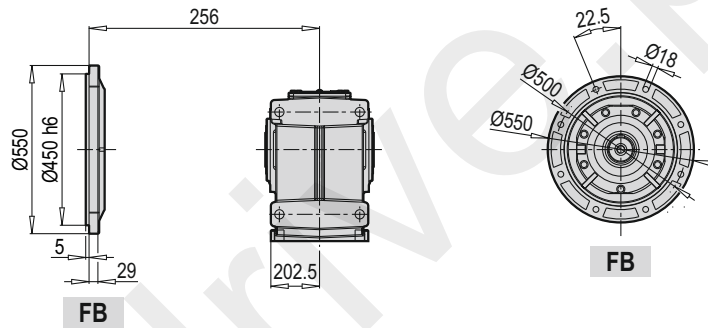

	160 M/L	180 M/L	200 L	225	250	280			
g	322	363	363	456	495	527			
g1	214	249	249	260	392	367			
k	1247	1352	1399	1428	1645	1721			
kBre	1352	1471	1517	1562	1825	-			
o	590	695	742	771	988	1064			

TMA - ÇMA / B14

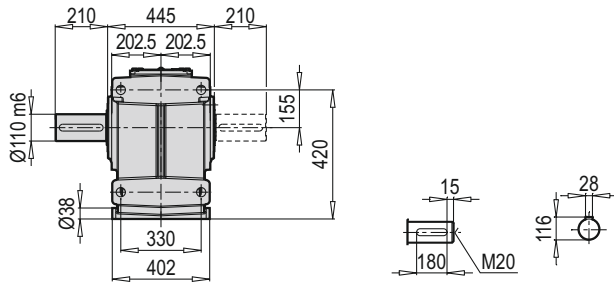

K 100390 DA/B14 PAM B5/B14

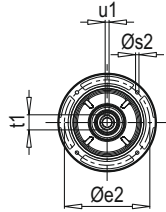
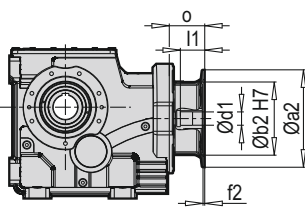

K 100390 DA/B14 W

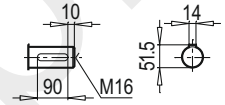
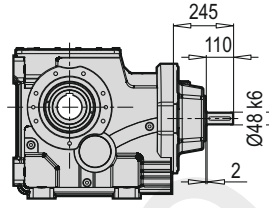

Typ / Type / Tipo Type / Tipo	PAM B5	Øa2	Øb2	Øe2	f2	Øs2	Ød1	l1	t1	u1	o
K 100390	160	350	250	300	7	16	42	112	45.3	12	109
	180	350	250	300	7	16	48	112	51.8	14	109
	200	400	300	350	7	16	55	112	59.3	16	146
	225	450	350	400	7	16	60	142	64.4	18	146
	250	550	450	500	7	16	65	142	69.4	18	175
	280	550	450	500	7	16	75	142	79.9	20	175

W ~ Kg	
K 100390	460

~ Kg	
PAM B5	K 100390
160	390
180	390
200	455
225	461
250	480
280	480

**Auswahltable von
W - PAM - IEC Adaptern**

Selection Tables
of W - PAM - IEC Adapters

Tabella si Selezione di
W - PAM - IEC Adattatore

Tableau de Sélection du
W - PAM - IEC Adaptateur

Tabla de Selección de
W - PAM - IEC Adaptador

**K...
35390 - 100390**

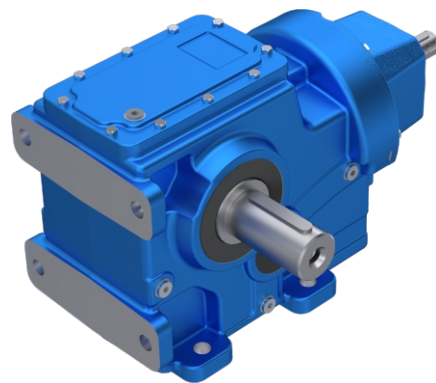
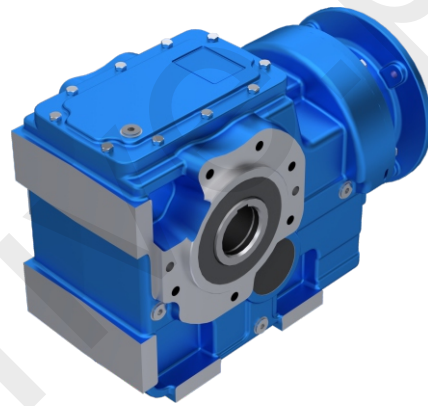

K...

Der Aufbau der Leistungstabelle für W - IEC und PAM-Adapter

Notify about performance tables for W and IEC adapter type
 Struttura delle tabelle delle prestazioni degli adattatori W - IEC e PAM
 La structure de la table de performance pour W - Adaptateur IEC et PAM
 Estructura de Tablas de Rendimiento para Adaptador de W - IEC ve PAM

K 35390 →

Getriebemotortyp /
 Gear unit motor type /
 Tipo del motore con ingranaggi /
 Type du moteur à engrenages /
 Tipo del motor con engranaje

max. Antriebsleistung
 Max. Input Power
 Max. potenza di ingresso
 Max. la puissance d'entrée
 máx. potencia de entrada

Betriebsfaktor f_B kann aus den Motorauswahlseiten entnommen werden, da für die IEC montierten Getriebe die Motor Körpergröße und IEC Körpergröße die gleichen sind.

Service factor f_B could be seen from selection of geared motor tables. Because this value is same for geared motor and geared motor with IEC adapters.

Peri riduttori a montaggio IEC con grandezza del corpo motore uguale alla grandezza del corpo motore IEC il fattore di Servizio puo'essere rilevato dalle scelte di motori f_B.

Facteur de service f_B peut être prise à partir de la page de sélection de moteur, pour réducteurs IEC montée dont moteur taille du corps et IEC taille du corps sont les mêmes.

Factor de servicio para reductores con IEC montado, y con mismo tamaño de cuerpo de IEC y el cuerpo de motor, se puede encontrar en paginas de elección f_B motor.

Typ / Type / Tipo / Type / Tipo	i _{ges}	4 - pol. 50 Hz 1400 rpm n ₂ [min ⁻¹]	M _{amax} f _B =1 4 - pol. [Nm]	W			IEC - PAM							
				P _{1max} 4 - pol. 1400 rpm [kW]	Fr1 [kN]	FR2 (a) [kN]	FR2 (b) [kN]	f _B ⇔ 50 - 92						
K 35390	158.67	8.9	600	0.62	1.1	12.0	6.3	63	71	80*				
	140.25	10.1	600	0.70	1.1	12.0	6.1	63	71	80*				
	125.18	11.3	600	0.79	1.1	12.0	5.8	63	71	80				
	112.63	12.5	600	0.87	1.1	12.0	5.6	63	71	80				
	102.00	13.8	600	0.97	1.1	12.0	5.4	63	71	80				
	91.04	15.5	600	1.08	1.1	12.0	5.2	63	71	80				
	78.09	18.1	600	1.26	1.1	12.0	4.9	63	71	80	90*			
	69.70	20.2	600	1.41	1.0	12.0	4.7	63	71	80	90			

Verkleinerungsfaktor
 Reduction ratio
 Rapporto di riduzione
 Rapport de réduction
 Relación de de reducción

Leistungsgeschwindigkeit
 Output speed
 Velocità di uscita
 Vitesse de sortie
 Velocidad de salida

Abtriebsdrehmoment
 Output torque
 Momento di uscita
 Moment de sortie
 Momento de salida

Bei der Berechnung der maximalen Antriebskraft wom Typ W werden keine kursiv Werte übernommen f_B mit P_{1max} = 1

P_{1max} value which is *non-italic* is calculated when service factor f_B is equal to one.

Nel calcolo della forza motrice massima tipo W sono stati presi valori non in corsivo. P_{1max} e f_B = 1

Bien que la force maximale de conduite de type W est calculé, les valeurs italiques ne sont pas prises. f_B avec P_{1max} = 1

Los valores no cursivos fueron tomados al calcular la fuerza motriz tipo W. P_{1max} con f_B = 1

IEC Motorgrößen und IEC-Standard-Ausgänge gemäß DIN EN 50347.

According to DIN EN 50347 IEC motor sizes.

Le grandezze dei motori IEC e le uscite standard IEC sono conformi a DIN EN 50347.

Tailles de moteurs IEC et les sorties standards IEC est selon la norme DIN EN 50347.

Tamaño de motores de IEC y salidas estandares de IEC son conformes a DIN EN 50347.

Bedruckte Bereiche zeigen, dass der IEC-Adapter für die IEC Motorgröße und den Verkleinerungsfaktor anwendbar ist.

This area which is colorless is shown IEC adapter is applicable for this IEC motor size and reduction ratio.

Gli spazi con cifre degli adattatori IEC, indicano che la grandezza del motore IEC è conforme al rapporto di trasmissione.

Zones numériques indiquent que l'adaptateur IEC est adapté pour IEC taille du moteur et taux de change.





Áreas con números indican que es adaptador de IEC, es conforme a tamaño del motor IEC y al ratio de cambios.

Zulässige max. radialkraft (Abtrieb)

Max. Permissible radial force (Output)
 Máx. Forza radiale ammessa (Uscita)
 Max. Force radiale admissible (Sortie)
 Max. Fuerza radial admissible (Salida)

Zulässige max. radialkraft (Antrieb)

Max. Permissible radial force (Input)
 Máx. Forza radiale ammessa (Entrata)
 Max. Force radiale admissible (Entree)
 Max. Fuerza radial admissible (Entrada)

Typ / Type / Tipo / Type / Tipo	i _{ges}	4 - pol. 50 Hz 1400 rpm n ₂ [min ⁻¹]	M _{amax} f _{B=1} 4 - pol. [Nm]	W			IEC - PAM													
				P _{1max} 4 - pol. 1400 rpm [kW]	Fr1 [kN]	FR2 (a) [kN]	FR2 (b) [kN]	f _B ⇔  50 - 92												
K 35390	158.67	8.9	600	0.62	1.1	12.0	6.3	63	71	80*										
	140.25	10.1	600	0.70	1.1	12.0	6.1	63	71	80*										
	125.18	11.3	600	0.79	1.1	12.0	5.8	63	71	80										
		112.63	12.5	600	0.87	1.1	12.0	5.6	63	71	80									
		102.00	13.8	600	0.97	1.1	12.0	5.4	63	71	80									
		91.04	15.5	600	1.08	1.1	12.0	5.2	63	71	80									
		78.09	18.1	600	1.26	1.1	12.0	4.9	63	71	80	90*								
	+ PAM - IEC	69.70	20.2	600	1.41	1.0	12.0	4.7	63	71	80	90*								
			57.38	24.6	600	1.72	1.0	12.0	4.3		71	80	90	100*	112*					
			51.21	27.6	600	1.92	1.0	12.0	4.1		71	80	90	100*	112*					
		43.56	32.4	600	2.26	1.0	12.0	3.9			80	90	100*	112*						
	38.88	36.3	600	2.53	0.9	12.0	3.7			80	90	100*	112*							
	33.70	41.9	600	2.92	0.9	12.0	3.5		71	80	90	100*	112*							
	28.25	49.9	600	3.49	0.8	11.4	3.3			80	90	100	112*							
	26.30	53.7	600	3.75	0.8	11.1	3.2			80	90	100	112*							
	22.50	62.5	600	4.36	0.7	10.4	3.0		71	80	90	100	112*							
	17.08	82.3	600	5.75	0.6	9.2	2.6			80	90	100	112							
	15.25	92.3	590	6.33	0.5	8.9	2.5			80	90	100	112							
	13.21	106.5	590	7.31	0.4	8.3	2.4		71	80	90	100	112							
	12.41	113.3	580	7.65	0.4	8.1	2.3			80	90	100	112							
11.08	127.0	540	7.98	0.3	7.9	2.3			80	90	100	112								
10.31	136.4	520	8.25	0.3	7.8	2.2			80	90	100	112								
9.20	152.8	460	8.18	0.3	7.7	2.2			80	90	100	112								
7.36	191.2	350	7.79	0.4	7.5	2.1		71	80	90	100	112								
6.91	203.5	340	8.05	0.3	7.3	2.1			80	90	100	112								
5.74	245.0	290	8.27	0.3	7.0	2.0			80	90	100	112								

Keine IEC - PAM-Verbindung / No IEC - PAM assembling on empty fields / Nessun assemblaggio IEC - PAM su campi vuoti / Pas d'assemblage IEC - PAM sur champs vides / Sin montaje IEC - PAM en campos vacíos

63 IEC - PAM-Verbindung möglich / IEC - PAM assembling available on numbered fields / Montaggio IEC - PAM disponibile su campi numerati / Assemblage IEC - PAM disponible sur champs numérotés / Assemblage IEC - PAM disponible sur champs numérotés /





80* Bei IEC - PAM-Verbindungen, sollten die P_{1max}-Werte nicht überschritten werden / Do not exceed the P_{1max} values indicated on fields with asterisk / Non superare i valori P_{1max} indicati sui campi con l'asterisco / Ne pas dépasser les valeurs P_{1max} indiquées sur les champs avec astérisque / No exceda los valores de P_{1max} indicados en los campos con asterisco

Typ / Type / Tipo / Type / Tipo	i _{ges}	4 - pol. 50 Hz 1400 rpm n ₂ [min ⁻¹]	M _{amax} f _{B=1} 4 - pol. [Nm]	W			IEC - PAM									
				P _{1max} 4 - pol. 1400 rpm [kW]	Fr1 [kN]	FR2 (a) [kN]	FR2 (b) [kN]	f _B ⇔ 50 - 92								
K 40390	142.18	9.8	850	0.97	2.5	18.0	9.5	80	90*	100*	112*					
	124.46	11.2	850	1.11	2.5	18.0	9.1	80	90*	100*	112*					
W 	114.17	12.3	850	1.21	2.5	18.0	8.8	80	90*	100*	112*					
	103.40	13.5	850	1.34	2.5	18.0	8.5	80	90*	100*	112*					
97	98.70	14.2	850	1.40	2.5	18.0	8.3	80	90*	100*	112*	132*				
	90.52	15.5	850	1.53	2.5	18.0	8.1	80	90	100*	112*					
+ PAM - IEC	79.26	17.7	850	1.75	2.5	18.0	7.7	80	90	100*	112*	132*				
	71.78	19.5	850	1.93	2.5	18.0	7.4	80	90	100*	112*	132*				
	67.78	20.7	850	2.04	2.5	18.0	7.2	80	90	100*	112*	132*				
	62.47	22.4	850	2.22	2.5	18.0	7.0	80	90	100*	112*	132*				
97	58.81	23.8	850	2.35	2.5	18.0	6.9	80	90	100*	112*	132*				
	54.43	25.7	850	2.54	2.5	18.0	6.7	80	90	100*	112*	132*				
	50.17	27.9	850	2.76	2.5	18.0	6.5	80	90	100*	112*	132*				
	44.78	31.3	850	3.09	2.5	18.0	6.2	80	90	100	112*	132*				
	42.28	33.1	850	3.27	2.5	18.0	6.0	80	90	100	112*	132*				
	38.97	35.9	850	3.55	2.5	18.0	5.9	80	90	100	112*	132*				
	33.95	41.2	850	4.08	2.5	18.0	5.5	80	90	100	112*	132*				
	31.29	44.7	850	4.42	2.5	18.0	5.4	80	90	100	112*	132*				
	28.83	48.6	850	4.80	2.4	18.0	5.2	80	90	100	112	132*				
	26.11	53.6	850	5.30	2.3	17.6	5.0	80	90	100	112	132*				
	22.40	62.5	850	6.18	2.2	16.5	4.7	80	90	100	112	132*				
	17.98	77.8	850	7.70	2.0	15.1	4.3	80	90	100	112	132*				
	16.29	86.0	850	8.50	1.9	14.5	4.1	80	90	100	112	132*				
	14.11	99.2	810	9.35	1.8	13.9	4.0	80	90	100	112	132				
	11.33	123.6	750	10.78	1.7	12.9	3.7	80	90	100	112	132				
	10.26	136.4	650	10.32	1.7	12.8	3.7	80	90	100	112	132				
	8.63	162.2	600	11.32	1.6	12.0	3.4	80	90	100	112	132				
	7.82	179.1	500	10.41	1.7	12.0	3.4	80	90	100	112	132				

Keine IEC - PAM-Verbindung / No IEC - PAM assembling on empty fields / Nessun assemblaggio IEC - PAM su campi vuoti / Pas d'assemblage IEC - PAM sur champs vides / Sin montaje IEC - PAM en campos vacíos

63 IEC - PAM-Verbindung möglich / IEC - PAM assembling available on numbered fields / Montaggio IEC - PAM disponibile su campi numerati / Assemblage IEC - PAM disponible sur champs numérotés / Assemblage IEC - PAM disponible sur champs numérotés /

80* Bei IEC - PAM-Verbindungen, sollten die P_{1max}-Werte nicht überschritten werden / Do not exceed the P_{1max} values indicated on fields with asterisk / Non superare i valori P_{1max} indicati sui campi con l'asterisco / Ne pas dépasser les valeurs P_{1max} indiquées sur les champs avec astérisque / No exceda los valores de P_{1max} indicados en los campos con asterisco

Typ / Type / Tipo / Type / Tipo	i _{ges}	4 - pol. 50 Hz 1400 rpm n ₂ [min ⁻¹]	M _{amax} f _{B=1} 4 - pol. [Nm]	W			IEC - PAM								
				P _{1max} 4 - pol. 1400 rpm [kW]	Fr1 [kN]	FR2 (a) [kN]	FR2 (b) [kN]	f _B ⇔  50 - 92							
K 50390	161.23	8.7	1800	1.82	2.8	22.0	11.8	80	90	100*	112*				
	141.14	9.9	1800	2.08	2.7	22.0	11.2	80	90	100*	112*				
W 	129.64	10.8	1800	2.26	2.7	22.0	10.9	80	90	100*	112*				
	117.49	11.9	1800	2.50	2.7	22.0	10.5	80	90	100*	112*				
	111.93	12.5	1800	2.62	2.7	22.0	10.3	80	90	100*	112*	132*			
	102.86	13.6	1800	2.85	2.7	22.0	10.0	80	90	100*	112*				
+ PAM - IEC	90.00	15.6	1800	3.26	2.6	22.0	9.5	80	90	100	112*	132*			
	81.57	17.2	1800	3.59	2.6	22.0	9.1	80	90	100	112*	132*			
	76.87	18.2	1700	3.60	2.6	22.0	9.0	80	90	100	112*	132*			
	70.84	19.8	1700	3.91	2.5	22.0	8.7	80	90	100	112*	132*			
	66.83	20.9	1700	4.14	2.5	22.0	8.5	80	90	100	112*	132*			
	63.93	21.9	1700	4.33	2.5	22.0	8.3	80	90	100	112	132*			
	56.96	24.6	1700	4.86	2.4	22.0	8.0	80	90	100	112	132*			
	51.63	27.1	1700	5.36	2.4	22.0	7.7	80	90	100	112	132*			
	48.89	28.6	1700	5.66	2.3	22.0	7.6			100	112	132*			
	46.59	30.0	1700	5.94	2.3	22.0	7.4	80	90	100	112	132*			
	43.91	31.9	1700	6.31	2.2	22.0	7.2	80	90	100	112	132*			
	40.46	34.6	1700	6.84	2.2	22.0	7.0	80	90	100	112	132*			
	35.30	39.7	1700	7.84	2.1	22.0	6.6	80	90	100	112	132*			
	32.54	43.0	1700	8.51	2.0	22.0	6.4	80	90	100	112	132*			
	29.67	47.2	1600	8.78	2.0	22.0	6.3	80	90	100	112	132*	160*		
	25.65	54.6	1500	9.53	1.9	21.1	6.0	80	90	100	112	132	160*		
	23.26	60.2	1400	9.80	1.8	20.4	5.8	80	90	100	112	132	160*		
	18.70	74.9	1400	12.19	1.6	18.7	5.3	80	90	100	112	132	160*		
	16.95	82.6	1400	13.45	1.4	18.0	5.1	80	90	100	112	132	160*		
	14.65	95.6	1200	13.34	1.4	17.6	5.0	80	90	100	112	132	160*		
	11.78	118.8	1000	13.83	1.4	16.7	4.8	80	90	100	112	132	160*		
	10.68	131.1	1000	15.25	1.2	16.1	4.6	80	90	100	112	132	160		
	8.98	156.0	900	16.32	1.0	15.1	4.3	80	90	100	112	132	160		
	8.13	172.1	800	16.03	1.1	14.9	4.2	80	90	100	112	132	160		

Keine IEC - PAM-Verbindung / No IEC - PAM assembling on empty fields / Nessun assemblaggio IEC - PAM su campi vuoti / Pas d'assemblage IEC - PAM sur champs vides / Sin montaje IEC - PAM en campos vacíos

63 IEC - PAM-Verbindung möglich / IEC - PAM assembling available on numbered fields / Montaggio IEC - PAM disponibile su campi numerati / Assemblage IEC - PAM disponible sur champs numérotés / Assemblage IEC - PAM disponible sur champs numérotés /





80* Bei IEC - PAM-Verbindungen, sollten die P_{1max}-Werte nicht überschritten werden / Do not exceed the P_{1max} values indicated on fields with asterisk / Non superare i valori P_{1max} indicati sui campi con l'asterisco / Ne pas dépasser les valeurs P_{1max} indiquées sur les champs avec astérisque / No exceda los valores de P_{1max} indicados en los campos con asterisco

Typ / Type / Tipo / Type / Tipo	i_{ges}	4 - pol. 50 Hz 1400 rpm n_2 [min ⁻¹]	M_{amax} $f_B=1$ 4 - pol. [Nm]	W				IEC - PAM							
				P_{1max} 4 - pol. 1400 rpm [kW]	Fr1 [kN]	FR2 (a) [kN]	FR2 (b) [kN]	$f_B \Rightarrow$ 50 - 92							
K 60390	183.08	7.6	3500	3.11	3.9	30.0	14.8	90	100	112*	132*				
	162.63	8.6	3500	3.51	3.8	30.0	14.0	90	100	112*	132*				
W 	146.59	9.6	3500	3.89	3.8	30.0	13.4	90	100	112*	132*				
	131.96	10.6	3500	4.32	3.8	30.0	12.8	90	100	112*	132*				
101	121.39	11.5	3500	4.70	3.8	30.0	12.3	90	100	112*	132*				
	108.31	12.9	3500	5.26	3.8	30.0	11.7	90	100	112	132*				
+ PAM - IEC	101.29	13.8	3500	5.63	3.7	30.0	11.3		100	112	132*	160*	180*		
	91.30	15.3	3500	6.24	3.7	30.0	10.8		100	112	132*	160*	180*		
	81.18	17.2	3500	7.02	3.7	30.0	10.2	90	100	112	132*				
	75.60	18.5	3500	7.54	3.6	30.0	9.9		100	112	132*	160*	180*		
101	70.62	19.8	3300	7.61	3.6	30.0	9.8		100	112	132*	160*	180*		
	63.65	22.0	3300	8.44	3.6	30.0	9.3		100	112	132*	160*	180*		
	60.34	23.2	3200	8.64	3.6	30.0	9.2		100	112	132*	160*	180*		
	55.28	25.3	3200	9.43	3.6	30.0	8.8		100	112	132	160*	180*		
	50.56	27.7	3200	10.31	3.5	29.6	8.5		100	112	132	160*	180*		
	45.57	30.7	3000	10.72	3.5	29.0	8.3		100	112	132	160*	180*		
	41.26	33.9	2800	11.05	3.5	28.5	8.2		100	112	132	160*	180*		
	35.25	39.7	2800	12.94	3.4	26.5	7.6		100	112	132	160*	180*		
	31.77	44.1	2800	14.36	3.3	25.1	7.2		100	112	132	160*	180*		
	31.39	44.6	2800	14.53	3.3	24.9	7.1				132	160*	180*		
	28.11	49.8	2800	16.22	3.2	23.6	6.7				132	160	180*		
	26.31	53.2	2800	17.33	3.2	22.8	6.5		100	112	132	160	180*		
	23.27	60.2	2800	19.60	3.1	21.4	6.1				132	160	180*		
	21.00	66.7	2500	19.39	3.1	21.6	6.2				132	160	180*		
	18.92	74.0	2200	18.94	3.1	21.9	6.3				132	160	180*		
	15.67	89.3	2100	21.83	3.0	20.4	5.8				132	160	180*		
	14.15	98.9	2100	24.17	2.8	19.4	5.5				132	160	180		
	12.75	109.8	2000	25.55	2.8	18.9	5.4				132	160	180		
	10.56	132.6	2000	30.85	2.5	17.2	4.9				132	160	180		
	9.63	145.4	1800	30.45	2.6	17.5	5.0				132	160	180		
	7.97	175.8	1500	30.66	2.6	17.3	4.9				132	160	180		

Keine IEC - PAM-Verbindung / No IEC - PAM assembling on empty fields / Nessun assemblaggio IEC - PAM su campi vuoti / Pas d'assemblage IEC - PAM sur champs vides / Sin montaje IEC - PAM en campos vacíos

63 IEC - PAM-Verbindung möglich / IEC - PAM assembling available on numbered fields / Montaggio IEC - PAM disponibile su campi numerati / Assemblage IEC - PAM disponible sur champs numérotés / Assemblage IEC - PAM disponible sur champs numérotés /

80* Bei IEC - PAM-Verbindungen, sollten die P_{1max} -Werte nicht überschritten werden / Do not exceed the P_{1max} values indicated on fields with asterisk / Non superare i valori P_{1max} indicati sui campi con l'asterisco / Ne pas dépasser les valeurs P_{1max} indiquées sur les champs avec astérisque / No exceda los valores de P_{1max} indicados en los campos con asterisco

Typ / Type / Tipo / Type / Tipo	i _{ges}	4 - pol. 50 Hz 1400 rpm n ₂ [min ⁻¹]	M _{amax} f _{B=1} 4 - pol. [Nm]	W			IEC - PAM									
				P _{1max} 4 - pol. 1400 rpm [kW]	Fr1 [kN]	FR2 (a) [kN]	FR2 (b) [kN]	f _B ⇔  50 - 92								
K 70390	183.27	7.6	5000	4.44	3.8	45.0	45.0	100	112*	132*						
	162.98	8.6	5000	5.00	3.8	45.0	45.0	100	112	132*	160*	180*				
W	146.38	9.6	5000	5.56	3.8	45.0	45.0	100	112	132*	160*	180*				
	133.53	10.5	5000	6.10	3.8	45.0	45.0	100	112	132*	160*	180*				
	121.96	11.5	5000	6.68	3.8	45.0	45.0	100	112	132*	160*	180*				
 103	109.54	12.8	5000	7.43	3.7	43.1	43.1	100	112	132*	160*	180*				
+	104.68	13.4	5000	7.78	3.7	42.0	42.0	100	112	132*						
PAM - IEC	93.09	15.0	5000	8.75	3.7	39.7	39.7	100	112	132*	160*	180*				
	83.66	16.7	5000	9.73	3.6	37.9	37.9	100	112	132	160*	180*	200*			
 103	76.27	18.4	5000	10.68	3.6	36.0	36.0	100	112	132	160*	180*				
	69.66	20.1	5000	11.69	3.6	34.4	34.4	100	112	132	160*	180*				
	63.37	22.1	5000	12.85	3.5	33.0	33.0	100	112	132	160*	180*	200*			
	58.32	24.0	5000	13.96	3.5	31.5	31.5	100	112	132	160*	180*	200*			
	53.98	25.9	5000	15.09	3.4	30.2	30.2	100	112	132	160	180*	200*			
	51.92	27.0	5000	15.69	3.4	29.8	29.8	100	112	132	160	180*	200*			
	47.78	29.3	5000	17.05	3.4	28.3	28.3	100	112	132	160	180*	200*			
	43.64	32.1	4800	17.92	3.3	27.7	27.7	100	112	132	160	180*	200*			
	39.27	35.6	4800	19.91	3.3	26.3	26.3			132	160	180*	200*			
	36.20	38.7	4800	21.60	3.2	25.0	25.0	100	112	132	160	180*	200*			
	32.18	43.5	4700	23.79	3.1	23.9	23.9			132	160	180	200*			
	29.66	47.2	4700	25.81	3.0	22.7	22.7	100	112	132	160	180	200*			
	27.09	51.7	4600	27.66	3.0	21.9	21.9	100	112	132	160	180	200*			
	24.90	56.2	4600	30.09	2.9	21.0	21.0			132	160	180	200			
	22.43	62.4	4400	31.95	2.8	20.3	20.3			132	160	180	200			
	20.40	68.6	4000	31.94	2.8	20.8	20.8			132	160	180	200			
	18.38	76.2	3600	31.90	2.8	20.9	20.9			132	160	180	200			
	16.79	83.4	3200	31.04	2.8	21.3	21.3			132	160	180	200			
	14.23	98.4	3100	35.48	2.7	19.9	19.9			132	160	180	200			
	11.65	120.1	3100	43.34	2.4	18.0	18.0			132	160	180	200			
	10.64	131.5	3000	45.93	2.3	17.5	17.5			132	160	180	200			

Keine IEC - PAM-Verbindung / No IEC - PAM assembling on empty fields / Nessun assemblaggio IEC - PAM su campi vuoti / Pas d'assemblage IEC - PAM sur champs vides / Sin montaje IEC - PAM en campos vacíos

63 IEC - PAM-Verbindung möglich / IEC - PAM assembling available on numbered fields / Montaggio IEC - PAM disponibile su campi numerati / Assemblage IEC - PAM disponible sur champs numérotés / Assemblage IEC - PAM disponible sur champs numérotés /





80* Bei IEC - PAM-Verbindungen, sollten die P_{1max}-Werte nicht überschritten werden / Do not exceed the P_{1max} values indicated on fields with asterisk / Non superare i valori P_{1max} indicati sui campi con l'asterisco / Ne pas dépasser les valeurs P_{1max} indiquées sur les champs avec astérisque / No exceda los valores de P_{1max} indicados en los campos con asterisco

Typ / Type / Tipo / Type / Tipo	i_{ges}	4 - pol. 50 Hz 1400 rpm n_2 [min ⁻¹]	M_{amax} $f_B=1$ 4 - pol. [Nm]	W			IEC - PAM								
				P_{1max} 4 - pol. 1400 rpm [kW]	Fr1 [kN]	FR2 (a) [kN]	FR2 (b) [kN]	$f_B \Rightarrow$ 50 - 92							
K 90390	168.56	8.3	8000	7.73	9.6	65.0	65.0	132*	160*	180*					
	152.10	9.3	8000	8.62	9.5	65.0	65.0	132*	160*	180*					
W 	136.87	10.2	8000	9.52	9.5	65.0	65.0	132	160*	180*					
	126.23	11.1	8000	10.32	9.4	65.0	65.0	132	160*	180*					
+ IEC 	105.17	13.3	8000	12.39	9.4	65.0	65.0	132	160*	180*	200*	225*			
	94.90	14.8	8000	13.73	9.3	65.0	65.0	132	160*	180*	200*	225*			
PAM - IEC 	88.87	15.8	8000	14.66	9.3	65.0	65.0	132	160*	180*					
	85.54	16.4	8000	15.23	9.2	65.0	65.0	132	160	180*					
+ IEC 	78.76	17.8	8000	16.54	9.2	64.1	64.1	132	160	180*	200*	225*			
	72.16	19.4	8000	18.06	9.1	62.1	62.1	132	160	180*					
PAM - IEC 	64.83	21.6	8000	20.10	9.0	59.4	59.4	132	160	180*					
	62.21	22.5	8000	20.95	9.0	58.4	58.4	132	160	180*					
+ IEC 	58.50	23.9	8000	22.27	8.9	57.0	57.0	132	160	180					
	55.45	25.2	8000	23.50	8.9	55.9	55.9	132	160	180	200*	225*			
+ IEC 	51.63	27.1	8000	25.24	8.8	54.2	54.2	132	160	180					
	48.55	28.8	8000	26.84	8.8	52.9	52.9	132	160	180					
+ IEC 	42.94	32.6	8000	30.35	8.6	50.5	50.5	132	160	180	200	225*			
	39.74	35.2	8000	32.79	8.5	48.7	48.7		160	180	200	225*			
+ IEC 	35.85	39.1	8000	36.35	8.4	46.7	46.7		160	180	200	225*			
	34.18	41.0	8000	38.12	8.3	45.9	45.9	132	160	180					
+ IEC 	30.84	45.4	8000	42.25	8.1	44.0	44.0	132	160	180					
	28.71	48.8	8000	45.39	8.0	42.7	42.7	132	160	180					
+ IEC 	25.60	54.7	6800	43.27	8.1	42.4	42.4	132	160	180					
	24.50	57.1	6700	44.54	8.0	41.7	41.7		160	180	200	225*			
+ IEC 	20.95	66.8	6500	50.54	7.8	39.5	39.5		160	180	200	225			
	18.90	74.1	6000	51.71	7.7	38.6	38.6		160	180	200	225			
+ IEC 	15.69	89.2	5000	51.91	7.7	37.2	37.2		160	180	200	225			
	14.32	97.8	5000	56.87	7.5	35.9	35.9		160	180	200	225			
+ IEC 	12.92	108.5	4500	56.73	7.5	35.1	35.1		160	180	200	225			
	10.72	130.6	4500	68.38	7.0	32.7	32.7		160	180	200	225			

Keine IEC - PAM-Verbindung / No IEC - PAM assembling on empty fields / Nessun assemblaggio IEC - PAM su campi vuoti / Pas d'assemblage IEC - PAM sur champs vides / Sin montaje IEC - PAM en campos vacíos

63 IEC - PAM-Verbindung möglich / IEC - PAM assembling available on numbered fields / Montaggio IEC - PAM disponibile su campi numerati / Assemblage IEC - PAM disponible sur champs numérotés / Assemblage IEC - PAM disponible sur champs numérotés /

80* Bei IEC - PAM-Verbindungen, sollten die P_{1max} -Werte nicht überschritten werden / Do not exceed the P_{1max} values indicated on fields with asterisk / Non superare i valori P_{1max} indicati sui campi con l'asterisco / Ne pas dépasser les valeurs P_{1max} indiquées sur les champs avec astérisque / No exceda los valores de P_{1max} indicados en los campos con asterisco

Typ / Type / Tipo / Type / Tipo	i _{ges}	4 - pol. 50 Hz 1400 rpm n ₂ [min ⁻¹]	M _{amax} f _{B=1} 4 - pol. [Nm]	W			IEC - PAM								
				P _{1max} 4 - pol. 1400 rpm [kW]	Fr1 [kN]	FR2 (a) [kN]	FR2 (b) [kN]	f _B ⇔  50 - 92							
K 100390	152.74	9.2	13000	13.86	10.0	80.0	65.0	160*	180*						
	136.95	10.2	13000	15.46	9.9	80.0	65.0	160	180*						
W 	124.56	11.2	13000	17.00	9.9	80.0	65.0	160	180*						
	112.66	12.4	13000	18.80	9.8	80.0	65.0	160	180*						
 107	102.47	13.7	13000	20.66	9.8	80.0	65.0	160	180*	200*					
	94.85	14.8	13000	22.32	9.7	80.0	65.0	160	180	200*					
+ PAM - IEC 	86.27	16.2	13000	24.55	9.7	80.0	65.0	160	180	200*					
	75.56	18.5	13000	28.02	9.6	80.0	65.0	160	180	200*					
 107	68.72	20.4	13000	30.81	9.5	80.0	65.0	160	180	200	225*				
	58.01	24.1	13000	36.50	9.4	80.0	65.0	160	180	200	225*	250*			
	52.76	26.5	13000	40.13	9.3	80.0	65.0	160	180	200	225*	250*			
	50.31	27.8	13000	42.09	9.2	80.0	65.0	160	180	200	225*				
	44.36	31.6	12000	44.06	9.2	78.2	65.0	160	180	200	225*	250*			
	40.07	34.9	12700	51.63	9.0	73.6	65.0	160	180	200	225	250*			
	36.96	37.9	12300	54.21	8.9	71.9	65.0	160	180	200	225	250*			
	33.62	41.6	11900	57.65	8.8	69.8	65.0	160	180	200	225	250			
	30.33	46.2	11500	61.76	8.7	67.5	65.0	160	180	200	225	250	280*		
	28.27	49.5	10200	58.77	8.8	67.7	65.0	160	180	200	225	250			
	26.01	53.8	11100	69.51	8.5	63.9	63.9	160	180	200	225	250	280*		
	23.66	59.2	10500	72.29	8.5	62.4	62.4	160	180	200	225	250	280*		
	21.43	65.3	10400	79.05	8.3	60.0	60.0	160	180	200	225	250	280*		
	19.61	71.4	10700	88.88	8.0	57.1	57.1	160	180	200	225	250			
	17.69	79.2	10400	95.76	7.9	55.1	55.1	160	180	200	225	250	280		
	16.09	87.0	9900	100.22	7.8	53.7	53.7		180	200	225	250	280		
	15.22	92.0	10000	107.02	7.6	52.3	52.3		180	200	225	250	280		
	13.80	101.5	9600	113.31	7.4	50.8	50.8		180	200	225	250	280		
	12.55	111.6	8800	114.21	7.4	50.1	50.1		180	200	225	250	280		
	11.64	120.3	7700	107.75	7.6	50.4	50.4		180	200	225	250	280		
	10.34	135.4	7900	124.45	7.1	47.6	47.6		180	200	225	250	280		
	8.69	161.0	6800	127.46	7.1	46.1	46.1		180	200	225	250	280		

Keine IEC - PAM-Verbindung / No IEC - PAM assembling on empty fields / Nessun assemblaggio IEC - PAM su campi vuoti / Pas d'assemblage IEC - PAM sur champs vides / Sin montaje IEC - PAM en campos vacíos

63 IEC - PAM-Verbindung möglich / IEC - PAM assembling available on numbered fields / Montaggio IEC - PAM disponibile su campi numerati / Assemblage IEC - PAM disponible sur champs numérotés / Assemblage IEC - PAM disponible sur champs numérotés /

80* Bei IEC - PAM-Verbindungen, sollten die P_{1max}-Werte nicht überschritten werden / Do not exceed the P_{1max} values indicated on fields with asterisk / Non superare i valori P_{1max} indicati sui campi con l'asterisco / Ne pas dépasser les valeurs P_{1max} indiquées sur les champs avec astérisque / No exceda los valores de P_{1max} indicados en los campos con asterisco

DE ALLGEMEINE TEILELISTE
FR GÉNÉRALE LA LISTE DES PIÈCES

EN GENERAL PART LIST
ES LISTE DE PIEZAS EN GENERAL

IT GENERALE ELENCO DELLE PARTI

K 35390 ... 100390
TMA - ÇMA

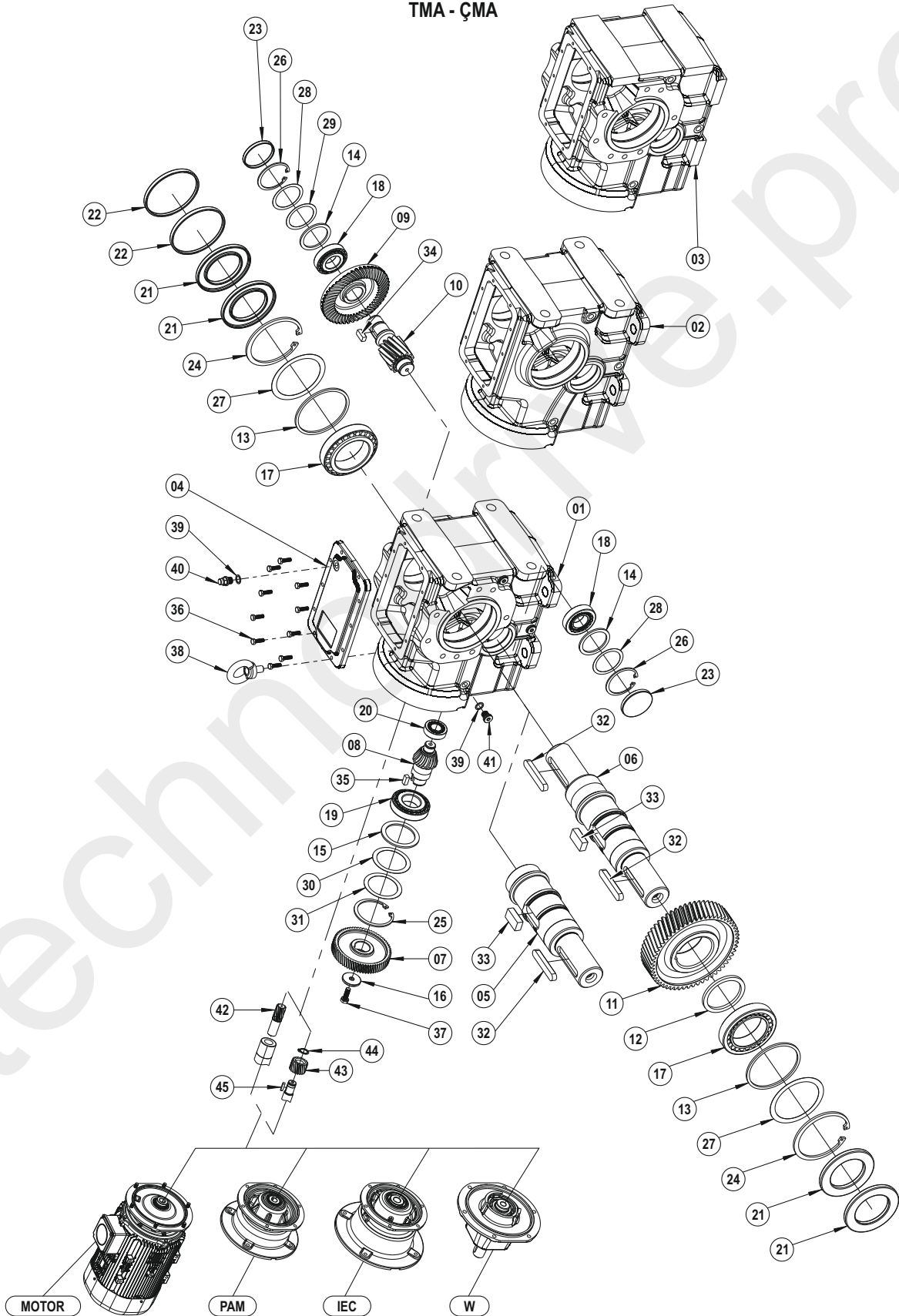

DE ALLGEMEINE TEILELISTE
FR GÉNÉRALE LA LISTE DES PIÈCES

EN GENERAL PART LIST
ES LISTE DE PIEZAS EN GENERAL

IT GENERALE ELENCO DELLE PARTI

01 Gehäuse (Mit Fuss-B14)	Gear Case (With Foot-B14)	Ingranaggi Box (Con piede-B14)	Corps (Avec pied-B14)	La caja de engranajes (Con pie-B14)
02 Gehäuse (Mit Fuss)	Gear Case (With Foot)	Ingranaggi Box (Con piede)	Corps (Avec pied)	La caja de engranajes (Con pie)
03 Gehäuse (Mit Flansch)	Gear Case (With Flange)	Ingranaggi Box (Con flangia)	Corps (Avec bride)	La caja de engranajes (Con brida)
04 Abdeckung	Cover	Coperchio	Couverture	Cubierta
05 Abtriebswelle	Output Solid Shaft	Albero pieno	Arbre de sortie	Eje sólido
06 Abtriebswelle	Output Solid Shaft	Doppio albero di uscita	Arbre de sortie double	Eje de doble salida
07 Antriebsrad	Driving Gear	Ingranaggio Conduttore	Rove d'entrée	Engranaje con ducido
08 Ritzelwelle	Pinion Shaft	Pignone	Arbre intermédiaire	Deleje del piñón
09 Abtriebsrad	Driven Gear	Ingranaggio Condotta	Rove de sortie	Engranaje conducido
10 Ritzelwelle	Pinion Shaft	Pignone di uscita	Arbre de pignon de sortie	El eje de piñón de salida
11 Abtriebsrad	Driven Gear	Albero di uscita	l'arbre de sortie	Eje de salida
12 Distanzbuchse	Spacer	Distanziatore	Bague de réduction	Espaciador
13 Distanzscheibe	Washer	Rondella	Rondelle	El apoyo a disco
14 Distanzscheibe	Washer	Rondella	Rondelle	El apoyo a disco
15 Distanzscheibe	Washer	Rondella	Rondelle	El apoyo a disco
16 Distanzscheibe	Washer	Rondella	Rondelle	El apoyo a disco
17 Kugellager	Bearing	Cuscinetto	Roulement à billes	Rodamiento de bolas
18 Kugellager	Bearing	Cuscinetto	Roulement à billes	Rodamiento de bolas
19 Kugellager	Bearing	Cuscinetto	Roulement à billes	Rodamiento de bolas
20 Kugellager	Bearing	Cuscinetto	Roulement à billes	Rodamiento de bolas
21 Öldichtung	Oil Seal	Paraolio	Joint Huile	Sello de aceite
22 Ölabdeckung	Oil Cover	Tappo di chiusura	Couverture d'huile	Tapón de cierre
23 Ölabdeckung	Oil Cover	Tappo di chiusura	Couverture d'huile	Tapón de cierre
24 Sicherungsring (DIN 472)	Circlip (DIN 472)	Anello di sicurezza (DIN 472)	Circlip (DIN 472)	Anillo de seguridad (DIN 472)
25 Sicherungsring (DIN 472)	Circlip (DIN 472)	Anello di sicurezza (DIN 472)	Circlip (DIN 472)	Anillo de seguridad (DIN 472)
26 Sicherungsring (DIN 472)	Circlip (DIN 472)	Anello di sicurezza (DIN 472)	Circlip (DIN 472)	Anillo de seguridad (DIN 472)
27 Passscheibe (DIN 988)	Shim (DIN 988)	Shim (DIN 988)	Rondelle d'ajustage (DIN 988)	Calce (DIN 988)
28 Passscheibe (DIN 988)	Shim (DIN 988)	Shim (DIN 988)	Rondelle d'ajustage (DIN 988)	Calce (DIN 988)
29 Passscheibe (DIN 988)	Shim (DIN 988)	Shim (DIN 988)	Rondelle d'ajustage (DIN 988)	Calce (DIN 988)
30 Passscheibe (DIN 988)	Shim (DIN 988)	Shim (DIN 988)	Rondelle d'ajustage (DIN 988)	Calce (DIN 988)
31 Passscheibe (DIN 988)	Shim (DIN 988)	Shim (DIN 988)	Rondelle d'ajustage (DIN 988)	Calce (DIN 988)
32 Passfeder (DIN 6885)	Key (DIN 6885)	Chiavetta (DIN 6885)	Clavette (DIN 6885)	Clave (DIN 6885)
33 Passfeder (DIN 6885)	Key (DIN 6885)	Chiavetta (DIN 6885)	Clavette (DIN 6885)	Clave (DIN 6885)
34 Passfeder (DIN 6885)	Key (DIN 6885)	Chiavetta (DIN 6885)	Clavette (DIN 6885)	Clave (DIN 6885)
35 Passfeder (DIN 6885)	Key (DIN 6885)	Chiavetta (DIN 6885)	Clavette (DIN 6885)	Clave (DIN 6885)
36 Verschrauben (DIN 933)	Bolt (DIN 933)	Bullone (DIN 933)	Boulonner (DIN 933)	Atornillar (DIN 933)
37 Verschrauben (DIN 933)	Bolt (DIN 933)	Bullone (DIN 933)	Boulonner (DIN 933)	Atornillar (DIN 933)
38 Ringschraube	Eye Bolt (DIN 580)	Vite ad anello	Anneau de levage (DIN 580)	Perno de anilla
39 Distanzscheibe (DIN 7603)	Washer (DIN 7603)	Rondella (DIN 7603)	Rondelle (DIN 7603)	El apoyo a disco (DIN 7603)
40 Entlüftungsstopfen	Vent Plug	Tappo di sfato	Bouchon d'évent	Ventilación
41 Ölstöpsel (DIN 908)	Oil Plug (DIN 908)	Olio Tappo (DIN 908)	Bouchon d'huile (DIN 908)	Tapón (DIN 908)
42 Antriebsritzel	Driving Pinion	Ingresso Pignone	Engrenage Z1	Piñón de entrada
43 Antriebsritzel (Mit Passfeder)	Driving Pinion (With Key)	Ingresso Pignone (Con chiavetta)	Engrenage Z1 (Avec clavette)	Piñón de entrada (Con clave)
44 Sicherungsring (DIN 471)	Segman (DIN 471)	Anello di sicurezza (DIN 471)	Circlip (DIN 471)	Anillo de seguridad (DIN 471)
45 Passfeder (DIN 6885)	Key (DIN 6885)	Chiavetta (DIN 6885)	Clavette (DIN 6885)	Clave (DIN 6885)

DE ALLGEMEINE TEILELISTE

EN GENERAL PART LIST

IT GENERALE ELENCO DELLE PARTI

FR GÉNÉRALE LA LISTE DES PIÈCES

ES LISTE DE PIEZAS EN GENERAL

K 35390 ... 100390

Abtriebsoptionen / Output Options / Opzioni di output / Options de sortie / Opciones de salida

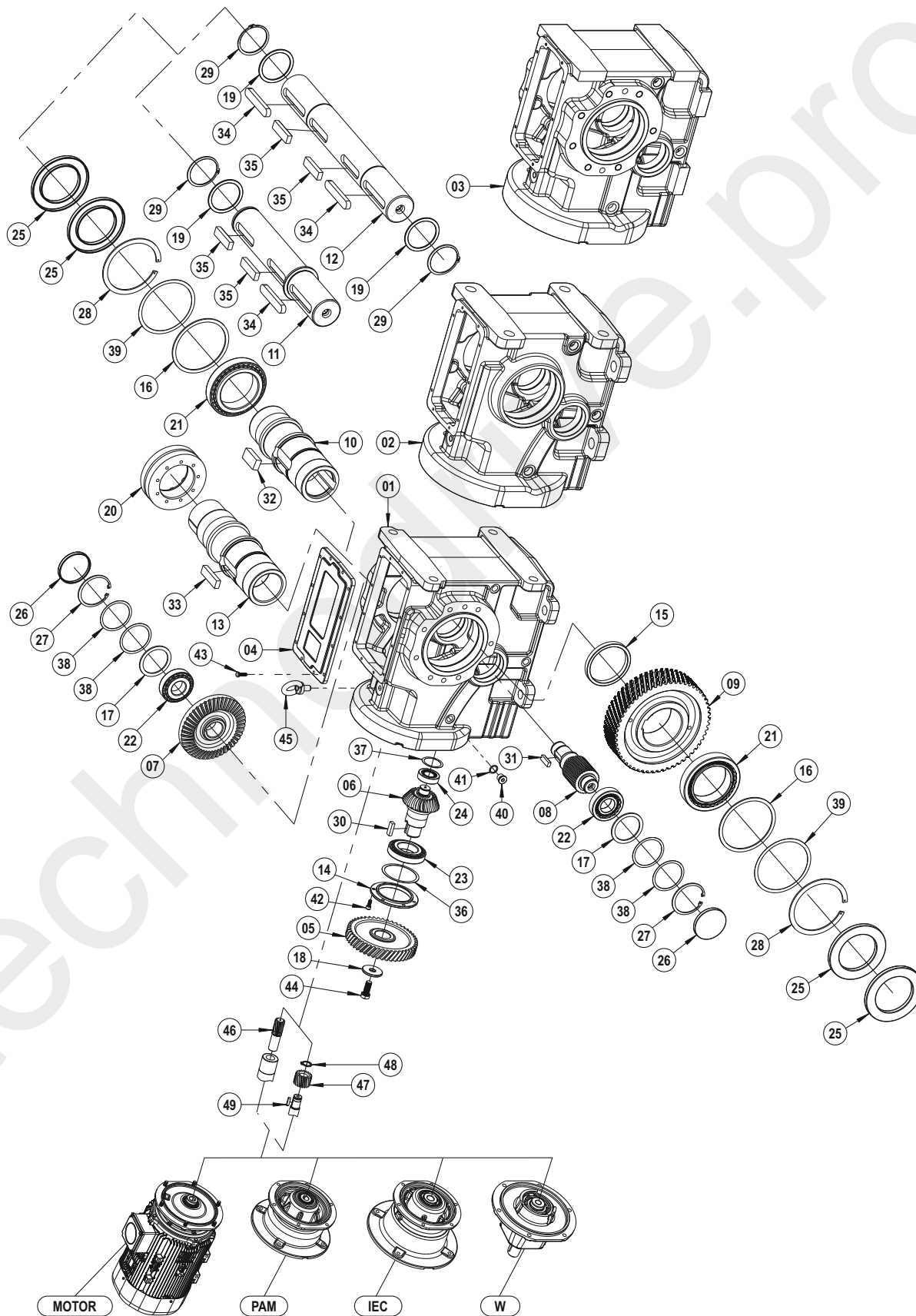

DE ALLGEMEINE TEILELISTE
FR GÉNÉRALE LA LISTE DES PIÈCES

EN GENERAL PART LIST
ES LISTE DE PIEZAS EN GENERAL

IT GENERALE ELENCO DELLE PARTI

01 Gehäuse (Mit Fuss-B14)	Gear Case (With Foot-B14)	Ingranaggi Box (Con piede-B14)	Corps (Avec pied-B14)	La caja de engranajes (Con pieB14)
02 Gehäuse (Fuss)	Gear Case (With Foot)	Ingranaggi Box (Con piede)	Corps (Avec pied)	La caja de engranajes (Con pie)
03 Gehäuse (Mit Flansch)	Gear Case (With Flange)	Ingranaggi Box (Con flangia)	Corps (Avec bride)	La caja de engranajes (Con brida)
04 Abdeckung	Cover	Coperchio	Couverture	Cubierta
05 Antriebsrad	Driving Gear	Ingranaggio Conduttore	Rove d'entrèe	Engranaje con ducido
06 Ritzelwelle	Pinion Shaft	Pignone	Arbre intermédiaire	Deleje del piñón
07 Abtriebsrad	Driven Gear	Ingranaggio Condotto	Rove de sortie	Engranaje conducido
08 Ritzelwelle	Pinion Shaft	Pignone di uscita	Arbre de pignon de sortie	El eje de piñón de salida
09 Abtriebsrad	Driven Gear	Albero di uscita	l'arbre de sortie	Eje de salida
10 Hohlwelle	Hollow Shaft	Albero di uscita	l'arbre de sortie	Eje de salida
11 Abtriebswelle (Mit Passfeder)	Output Solid Shaft (With Key)	Albero pieno (Con chiavetta)	Arbre de sortie (Avec clavette)	Eje sólido (Con clave)
12 Abtriebswelle (Mit Passfeder)	Output Solid Shaft (With Key)	Doppio albero di uscita (Con chiavetta)	Arbre de sortie double (Avec clavette)	Eje de doble salida (Con clave)
13 Schrumpfscheibe Hohlwelle	Shrink Disk Hollow Shaft	Albero cavo con boccola di seraggio	Arbre creux avec frette de desserage	Eje hueco anillo de contraccion
14 Lagerflansch	Bearing Flange	Staffa di supporto	la bride de palier	Brida de apoyo
15 Distanzbuchse	Spacer	Distanziatore	Bague de réduction	Espaciador
16 Distanzscheibe	Washer	Rondella	Rondelle	El apoyo a disco
17 Distanzscheibe	Washer	Rondella	Rondelle	El apoyo a disco
18 Distanzscheibe	Washer	Rondella	Rondelle	El apoyo a disco
19 Distanzscheibe	Washer	Rondella	Rondelle	El apoyo a disco
20 Schrumpfscheibe	Shrink Disk	Calettatore	Frette d'accouplement	Aro de apriete
21 Kugellager	Bearing	Cuscinetto	Roulement à billes	Rodamiento de bolas
22 Kugellager	Bearing	Cuscinetto	Roulement à billes	Rodamiento de bolas
23 Kugellager	Bearing	Cuscinetto	Roulement à billes	Rodamiento de bolas
24 Kugellager	Bearing	Cuscinetto	Roulement à billes	Rodamiento de bolas
25 Öldichtung	Oil Seal	Paraolio	Bague d'etancheite	Sello de aceite
26 Ölabdeckung	Oil Cover	Tappo di chiusura	Couverture d'huile	Tapón de cierre
27 Sicherungsring (DIN 472)	Circlip (DIN 472)	Anello di sicurezza (DIN 472)	Circlip (DIN 472)	Anillo de seguridad (DIN 472)
28 Sicherungsring (DIN 472)	Circlip (DIN 472)	Anello di sicurezza (DIN 472)	Circlip (DIN 472)	Anillo de seguridad (DIN 472)
29 Sicherungsring (DIN 471)	Circlip (DIN 471)	Anello di sicurezza (DIN 471)	Circlip (DIN 471)	Anillo de seguridad (DIN 471)
30 Passfeder (DIN 6885)	Key (DIN 6885)	Chiavetta (DIN 6885)	Clavette (DIN 6885)	Clave (DIN 6885)
31 Passfeder (DIN 6885)	Key (DIN 6885)	Chiavetta (DIN 6885)	Clavette (DIN 6885)	Clave (DIN 6885)
32 Passfeder (DIN 6885)	Key (DIN 6885)	Chiavetta (DIN 6885)	Clavette (DIN 6885)	Clave (DIN 6885)
33 Passfeder (DIN 6885)	Key (DIN 6885)	Chiavetta (DIN 6885)	Clavette (DIN 6885)	Clave (DIN 6885)
34 Passfeder (DIN 6885)	Key (DIN 6885)	Chiavetta (DIN 6885)	Clavette (DIN 6885)	Clave (DIN 6885)
35 Passfeder (DIN 6885)	Key (DIN 6885)	Chiavetta (DIN 6885)	Clavette (DIN 6885)	Clave (DIN 6885)
36 Passscheibe (DIN 988)	Shim (DIN 988)	Shim (DIN 988)	Rondelle d'ajustage (DIN 988)	Calce (DIN 988)
37 Passscheibe (DIN 988)	Shim (DIN 988)	Shim (DIN 988)	Rondelle d'ajustage (DIN 988)	Calce (DIN 988)
38 Passscheibe (DIN 988)	Shim (DIN 988)	Shim (DIN 988)	Rondelle d'ajustage (DIN 988)	Calce (DIN 988)
39 Passscheibe (DIN 988)	Shim (DIN 988)	Shim (DIN 988)	Rondelle d'ajustage (DIN 988)	Calce (DIN 988)
40 Ölstöpsel (DIN 908)	Oil Plug (DIN 908)	Olio Tappo (DIN 908)	Bouchon d'huile (DIN 908)	Tapón (DIN 908)
41 Distanzscheibe (DIN 7603)	Washer (DIN 7603)	Rondella (DIN 7603)	Rondelle (DIN 7603)	El apoyo a disco (DIN 7603)
42 Verschrauben (DIN 933)	Bolt (DIN 933)	Bullone (DIN 933)	Boulonner (DIN 933)	Atornillar (DIN 933)
43 Verschrauben (DIN 933)	Bolt (DIN 933)	Bullone (DIN 933)	Boulonner (DIN 933)	Atornillar (DIN 933)
44 Verschrauben (DIN 933)	Bolt (DIN 933)	Bullone (DIN 933)	Boulonner (DIN 933)	Atornillar (DIN 933)
45 Ringschraube (DIN 580)	Eye Bolt (DIN 580)	Vite ad anello (DIN 580)	Anneau de levage (DIN 580)	Perno de anilla (DIN 580)
46 Antriebsritzel	Driving Pinion	Ingresso Pignone	Engrenage Z1	Piñón de entrada
47 Antriebsritzel (Mit Passfeder)	Driving Pinion (With Key)	Ingresso Pignone (Con chiavetta)	Engrenage Z1 (Avec clavette)	Piñón de entrada (Con clave)
48 Sicherungsring (DIN 471)	Circlip (DIN 471)	Anello di sicurezza (DIN 471)	Circlip (DIN 471)	Anillo de seguridad (DIN 471)
49 Passfeder (DIN 6885)	Key (DIN 6885)	Chiavetta (DIN 6885)	Clavette (DIN 6885)	Clave (DIN 6885)

DE ALLGEMEINE TEILELISTE
FR GÉNÉRALE LA LISTE DES PIÈCES

EN GENERAL PART LIST
ES LISTE DE PIEZAS EN GENERAL

IT GENERALE ELENCO DELLE PARTI

K 35390 ... 100390

Zubehör / Accessories / Accessori / Accessoires / Accessorios

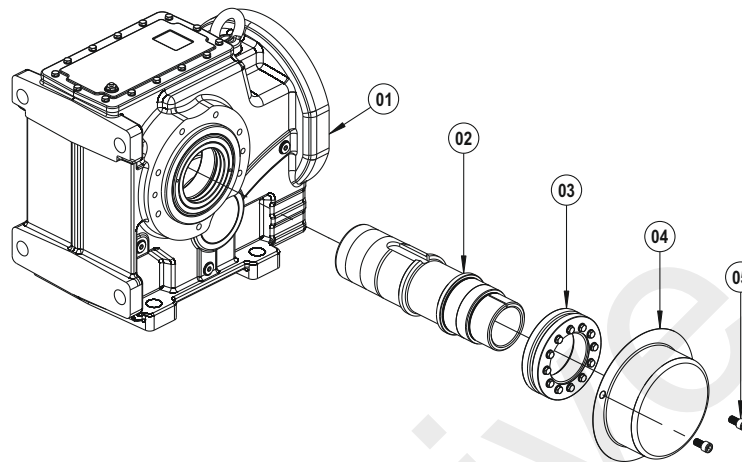

**Schrumpfscheibe (KS)
Schutzhülle (KK)**

- 01 K-AF Bausatz
- 02 Schrumpfscheibe Hohlwelle
- 03 Schrumpfscheibe
- 04 Schrumpfscheibendeckel
- 05 Verschrauben (DIN 912)

**Shrink Disk (KS)
Protection Cover (KK)**

- K-AF Kit
- Shrink Disk Hollow Shaft
- Shrink Disk
- Shrink Disk Cover
- Bolt (DIN 912)

**Calettatore (KS)
Copertura di protezione (KK)**

- K-AF Kit
- Albero cavo con boccia di seraggio
- Calettatore
- Copertura di protezione
- Bullone (DIN 912)

**Frette d'accouplement (KS)
Housse de protection (KK)**

- K-AF Kit
- Arbre creux avec frette de desserage
- Frette d'accouplement
- Housse de protection
- Boulonner (DIN 912)

**Aro de apriete (KS)
Cubierta de protección (KK)**

- K-AF Kit
- Eje hueco anillo de contraccion
- Aro de apriete
- Cubierta de protección
- Atomillar (DIN 912)

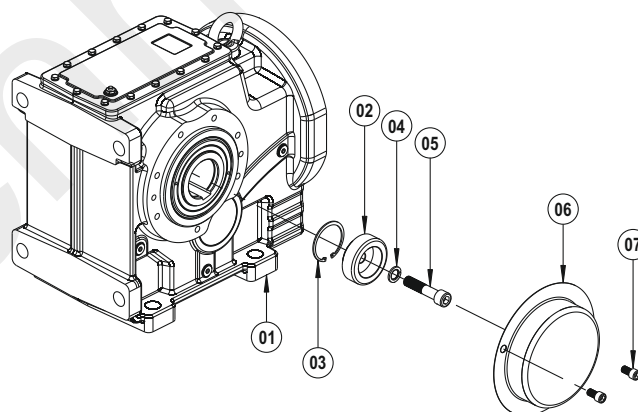

**Befestigungsbausatz (Ç)
Schutzhülle (KK)**

- 01 K-AF Bausatz
- 02 Befestigungsscheibe
- 03 Sicherungsring (DIN 472)
- 04 Distanzscheibe (DIN 127)
- 05 Verschrauben (DIN 912)
- 06 Schutzhülle
- 07 Verschrauben (DIN 912)

**Puller (Ç)
Protection Cover (KK)**

- K-AF Kit
- Puller Washer
- Circlip (DIN 472)
- Washer (DIN 127)
- Bolt (DIN 912)
- Protection Cover
- Bolt (DIN 912)

**Elementi De Fissaggio (Ç)
Copertura di protezione (KK)**

- K-AF Kit
- Elementi De Fissaggio
- Anello di sicurezza (DIN 472)
- Rondella (DIN 127)
- Bullone (DIN 912)
- Copertura di protezione
- Bullone (DIN 912)

**Éléments De Fixation (Ç)
Housse de protection (KK)**

- K-AF Kit
- Rondelle d'extracteur
- Circlip (DIN 472)
- Rondelle (DIN 127)
- Boulonner (DIN 912)
- Housse de protection
- Boulonner (DIN 912)

**Elementos Ds Fijación (Ç)
Cubierta de protección (KK)**

- K-AF Kit
- Elementos Ds Fijación
- Anillo de seguridad (DIN 472)
- El apoyo a disco (DIN 127)
- Atomillar (DIN 912)
- Cubierta de protección
- Atomillar (DIN 912)

DE ALLGEMEINE TEILELISTE

EN GENERAL PART LIST

IT GENERALE ELENCO DELLE PARTI

FR GÉNÉRALE LA LISTE DES PIÈCES

ES LISTE DE PIEZAS EN GENERAL

Zubehör / Accessories / Accessori / Accessoires / Accesorios

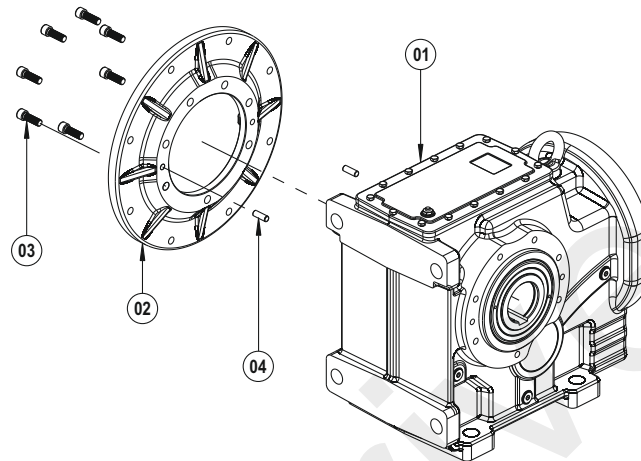

B5 Abtriebsflansch

- 01 K-AF Bausatz
- 02 B5 Abtriebsflansch
- 03 Verschrauben (DIN 912)
- 04 Bolzen

B5 Output Flange

- K-AF Kit
- B5 Output Flange
- Bolt (DIN 912)
- Pin

B5 Flangia d'uscita

- K-AF Kit
- B5 Flangia d'uscita
- Bullone (DIN 912)
- Pin

B5 Bride sortie

- K-AF Kit
- B5 Bride sortie
- Boulonner (DIN 912)
- Goupille

B5 Brida de solida

- K-AF Kit
- B5 Brida de solida
- Atornillar (DIN 912)
- Pasador

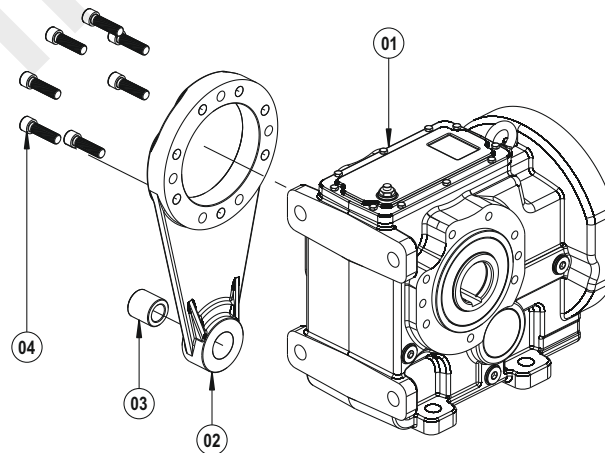

Drehmomentenstütze (TK)

- 01 K-AF Bausatz
- 02 Drehmomentenstütze
- 03 Gummipuffer
- 04 Verschrauben (DIN 912)

Torque Arm (TK)

- K-AF Kit
- Torque Arm
- Rubber Buffer
- Bolt (DIN 912)

Braccio di reazione (TK)

- K-AF Kit
- Braccio di reazione
- Paracolpi in gomma
- Bullone (DIN 912)

Bras de réaction (TK)

- K-AF Kit
- Bras de réaction
- Tampon de caoutchouc
- Boulonner (DIN 912)

Brazo de reacción (TK)

- K-AF Kit
- Brazo de reacción
- Tape de goma
- Atornillar (DIN 912)

DE ALLGEMEINE TEILELISTE
FR GÉNÉRALE LA LISTE DES PIÈCES

EN GENERAL PART LIST
ES LISTE DE PIEZAS EN GENERAL

IT GENERALE ELENCO DELLE PARTI

Zubehör / Accessories / Accessori / Accessoires / Accesorios

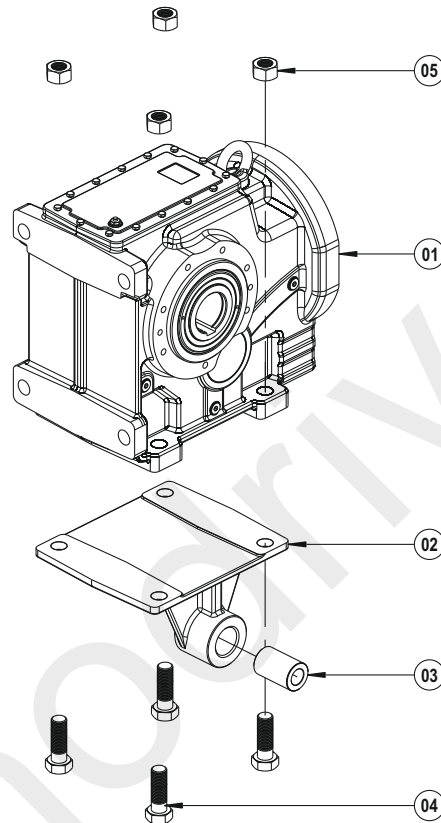

Drehmomentenkonsolle (TKP)

- 01 K-AF Bausatz
- 02 Drehmomentenkonsolle
- 03 Gummipuffer
- 04 Verschrauben (DIN 933)
- 05 Schraubenmutter (DIN 934)

Torque Arm Platform (TKP)

- K-AF Kit
- Torque Arm Platform
- Rubber Buffer
- Bolt (DIN 933)
- Nut (DIN 934)

Piattaforma del braccio di torcente (TKP)

- K-AF Kit
- Piattaforma del braccio di torcente
- Paracolpi in gomma
- Bullone (DIN 933)
- Dado (DIN 934)

Plate-forme de bras de torsion (TKP)

- K-AF Kit
- Plate-forme de bras de torsion
- Tampon de caoutchouc
- Boulonner (DIN 933)
- Ecrou (DIN 934)

Plataforma de brazo de torsión (TKP)

- K-AF Kit
- Plataforma de brazo de torsión
- Tape de goma
- Atornillar (DIN 933)
- Tuerca (DIN 934)

DE ALLGEMEINE TEILELISTE

EN GENERAL PART LIST

IT GENERALE ELENCO DELLE PARTI

FR GÉNÉRALE LA LISTE DES PIÈCES

ES LISTE DE PIEZAS EN GENERAL

IEC 63 ... 280

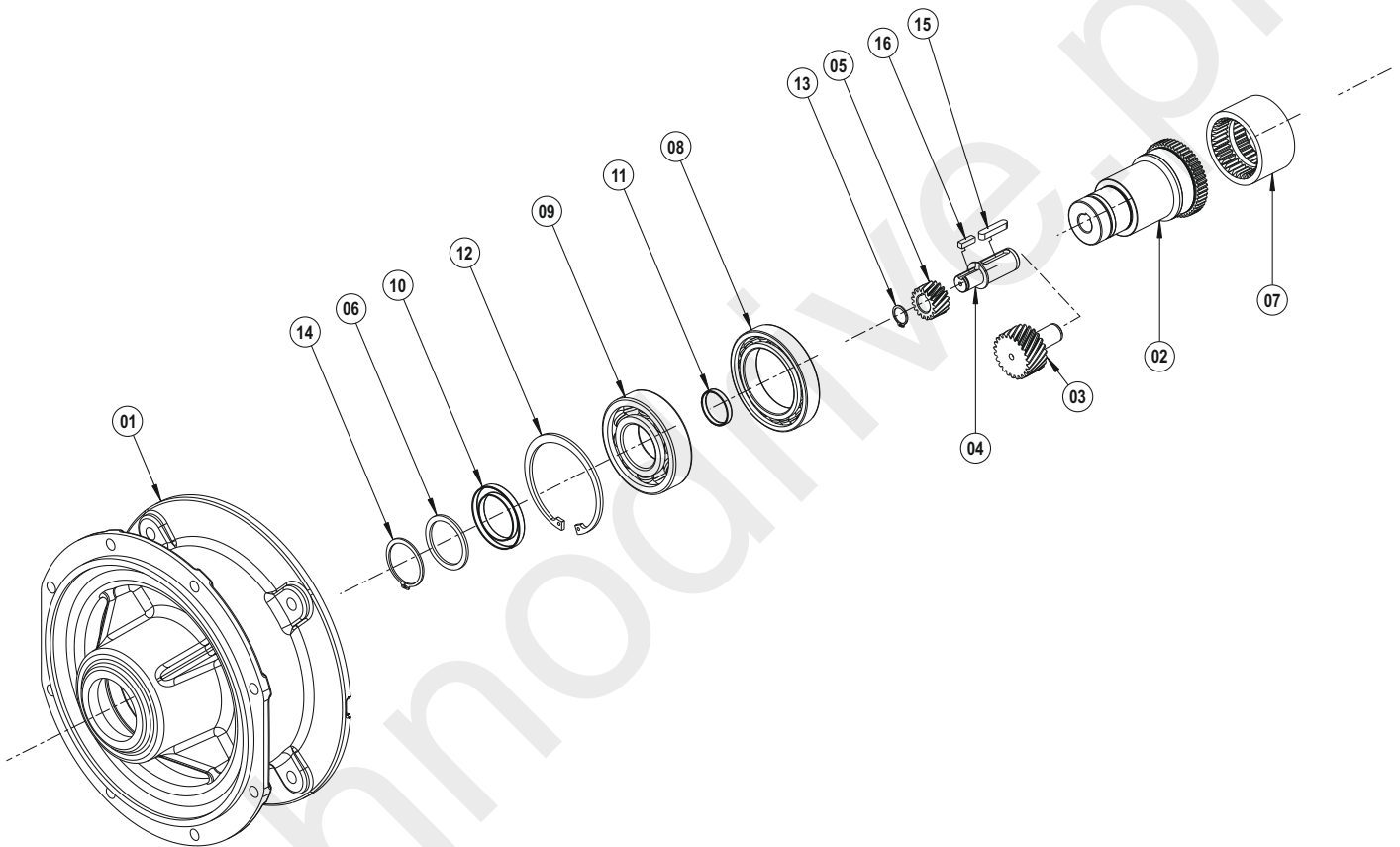

01 Gehäuse	Gear Case	Ingranaggi Box	Corps	La caja de engranajes
02 IEC Welle	IEC Shaft	IEC Albero	IEC Arbre	IEC Eje
03 Antriebsritzel	Driving Pinion	Ingresso Pignone	Engrenage Z1	Piñón de entrada
04 Ritzelwelle (Mit Passfeder)	Pinion Shaft (With Key)	Pignone (Con chiave)	Arbre Pignon (Avec clavette)	Eje del piñón (Con clave)
05 Antriebsritzel (Mit Passfeder)	Driving Pinion (With Key)	Ingresso Pignone (Con chiave)	Engrenage Z1 (Avec clavette)	Piñón de entrada (Con clave)
06 Distanzscheibe	Washer	Rondella	Rondelle	El apoyo a disco
07 Kupplung	Coupling	Accoppiamento	Accouplement	Enganche
08 Kugellager	Bearing	Cuscinetto	Roulement à billes	Rodamiento de bolas
09 Kugellager	Bearing	Cuscinetto	Roulement à billes	Rodamiento de bolas
10 Öldichtung	Oil Seal	Paraolio	Joint Huile	Sello de aceite
11 Ölabdeckung	Oil Cover	Tappo di chiusura	Couverture d'huile	Tapón de cierre
12 Sicherungsring (DIN 472)	Circlip (DIN 472)	Anello di sicurezza (DIN 472)	Circlip (DIN 472)	Anillo de seguridad (DIN 472)
13 Sicherungsring (DIN 471)	Circlip (DIN 471)	Anello di sicurezza (DIN 471)	Circlip (DIN 471)	Anillo de seguridad (DIN 471)
14 Sicherungsring (DIN 471)	Circlip (DIN 471)	Anello di sicurezza (DIN 471)	Circlip (DIN 471)	Anillo de seguridad (DIN 471)
15 Passfeder (DIN 6885)	Key (DIN 6885)	Chiavetta (DIN 6885)	Clavette (DIN 6885)	Clave (DIN 6885)
16 Passfeder (DIN 6885)	Key (DIN 6885)	Chiavetta (DIN 6885)	Clavette (DIN 6885)	Clave (DIN 6885)

DE ALLGEMEINE TEILELISTE
FR GÉNÉRALE LA LISTE DES PIÈCES

EN GENERAL PART LIST
ES LISTE DE PIEZAS EN GENERAL

IT GENERALE ELENCO DELLE PARTI

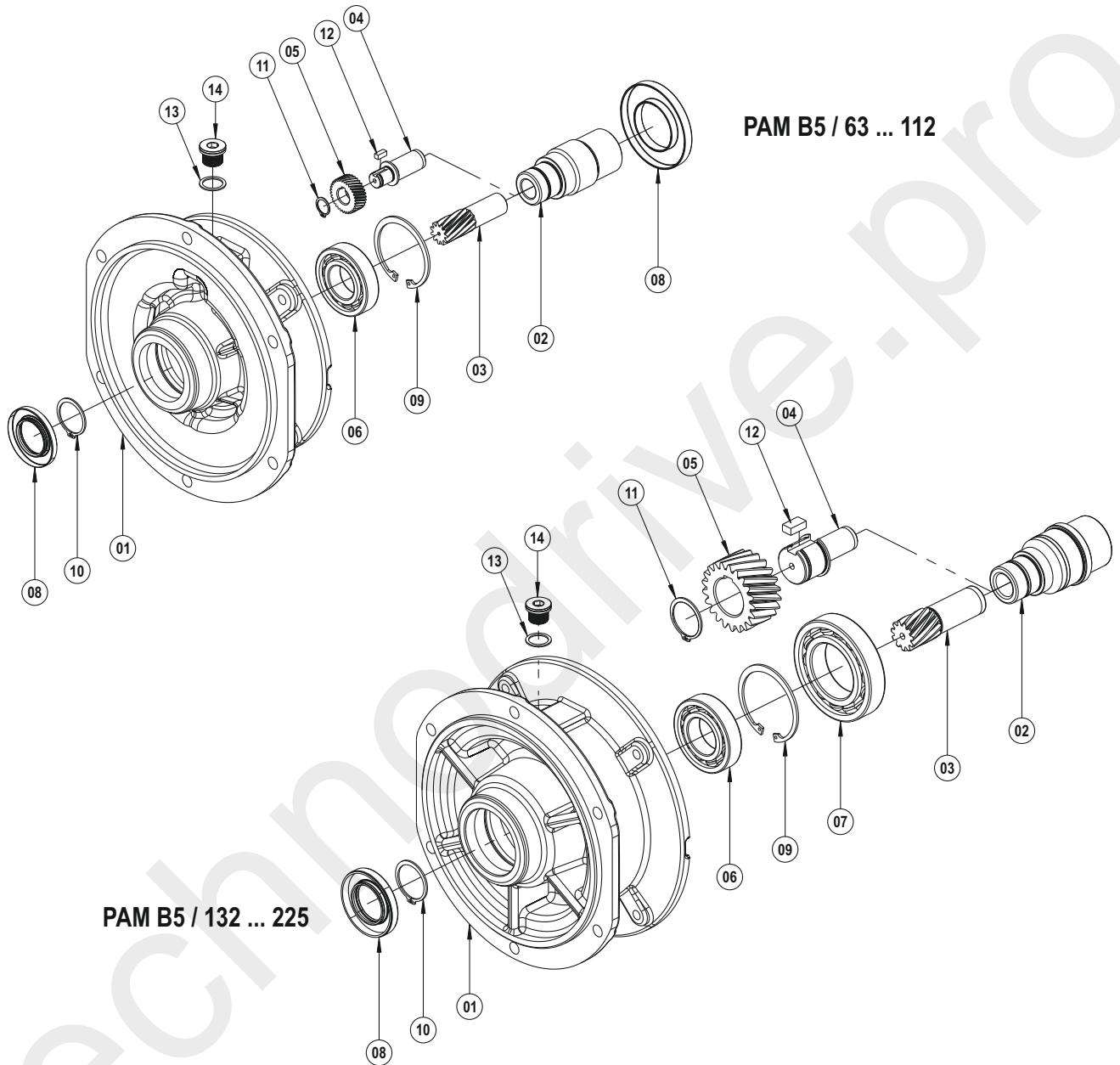

PAM B5 / 63 ... 112

PAM B5 / 132 ... 225

01 Gehäuse	Gear Case	Ingranaggi Box	Corps	La caja de engranajes
02 PAM Welle	PAM Shaft	PAM albero	PAM Arbre	PAM eje
03 Antriebsritzel	Driving Pinion	Ingresso Pignone	Engrenage Z1	Piñón de entrada
04 Ritzelwelle (Mit Passfeder)	Pinion Shaft (With Key)	Pignone (Con chiavetta)	Arbre Pignon (Avec clavette)	Eje del piñón (Con clave)
05 Antriebsritzel (Mit Passfeder)	Driving Pinion (With Key)	Ingresso Pignone (Con chiavetta)	Engrenage Z1 (Avec clavette)	Piñón de entrada (Con clave)
06 Kugellager	Bearing	Cuscinetto	Roulement à billes	Rodamiento de bolas
07 Kugellager	Bearing	Cuscinetto	Roulement à billes	Rodamiento de bolas
08 Öldichtung	Oil Seal	Paraolio	Joint Huile	Sello de aceite
09 Sicherungsring (DIN 472)	Circlip (DIN 472)	Anello di sicurezza (DIN 472)	Circlip (DIN 472)	Anillo de seguridad (DIN 472)
10 Sicherungsring (DIN 471)	Circlip (DIN 471)	Anello di sicurezza (DIN 471)	Circlip (DIN 471)	Anillo de seguridad (DIN 471)
11 Sicherungsring (DIN 471)	Circlip (DIN 471)	Anello di sicurezza (DIN 471)	Circlip (DIN 471)	Anillo de seguridad (DIN 471)
12 Passfeder (DIN 6885)	Key (DIN 6885)	Chiavetta (DIN 6885)	Clavette (DIN 6885)	Clave (DIN 6885)
13 Distanzscheibe (DIN 7603)	Washer (DIN 7603)	Rondella (DIN 7603)	Rondelle (DIN 7603)	El apoyo a disco (DIN 7603)
14 Ölstopfel (DIN 908)	Oil Plug (DIN 908)	Olio Tappo (DIN 908)	Bouchon d'huile (DIN 908)	Tapón (DIN 908)

DE ALLGEMEINE TEILELISTE

EN GENERAL PART LIST

IT GENERALE ELENCO DELLE PARTI

FR GÉNÉRALE LA LISTE DES PIÈCES

ES LISTE DE PIEZAS EN GENERAL

PAM B14 / 63 ... 132

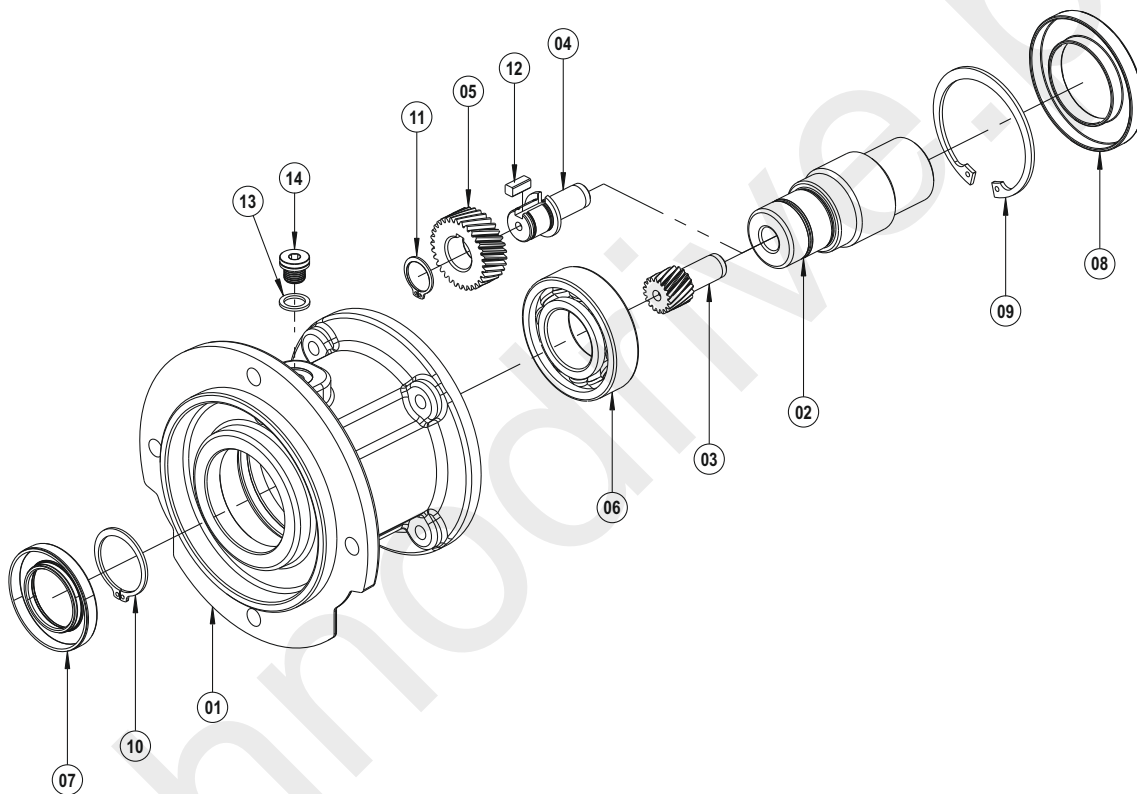

01 Gehäuse	Gear Case	Ingranaggi Box	Corps	La caja de engranajes
02 PAM Welle	PAM Shaft	PAM albero	PAM Arbre	PAM eje
03 Antriebsritzel	Driving Pinion	Ingresso Pignone	Engrenage Z1	Piñón de entrada
04 Ritzelwelle (Mit Passfeder)	Pinion Shaft (With Key)	Pignone (Con chiavetta)	Arbre Pignon (Avec clavette)	Eje del piñón (Con clave)
05 Antriebsritzel (Mit Passfeder)	Driving Pinion (With Key)	Ingresso Pignone (Con chiavetta)	Engrenage Z1 (Avec clavette)	Piñón de entrada (Con clave)
06 Kugellager	Bearing	Cuscinetto	Roulement à billes	Rodamiento de bolas
07 Öldichtung	Oil Seal	Paraolio	Joint Huile	Sello de aceite
08 Öldichtung	Oil Seal	Paraolio	Joint Huile	Sello de aceite
09 Sicherungsring (DIN 472)	Circlip (DIN 472)	Anello di sicurezza (DIN 472)	Circlip (DIN 472)	Anillo de seguridad (DIN 472)
10 Sicherungsring (DIN 471)	Circlip (DIN 471)	Anello di sicurezza (DIN 471)	Circlip (DIN 471)	Anillo de seguridad (DIN 471)
11 Sicherungsring (DIN 471)	Circlip (DIN 471)	Anello di sicurezza (DIN 471)	Circlip (DIN 471)	Anillo de seguridad (DIN 471)
12 Passfeder (DIN 6885)	Key (DIN 6885)	Chiavetta (DIN 6885)	Clavette (DIN 6885)	Clave (DIN 6885)
13 Distanzscheibe (DIN 7603)	Washer (DIN 7603)	Rondella (DIN 7603)	Rondelle (DIN 7603)	El apoyo a disco (DIN 7603)
14 Ölstopfel (DIN 908)	Oil Plug (DIN 908)	Olio Tappo (DIN 908)	Bouchon d'huile (DIN 908)	Tapón (DIN 908)

DE ALLGEMEINE TEILELISTE
FR GÉNÉRALE LA LISTE DES PIÈCES

EN GENERAL PART LIST
ES LISTE DE PIEZAS EN GENERAL

IT GENERALE ELENCO DELLE PARTI

W 140 - 173 - 207 - 245 - 250

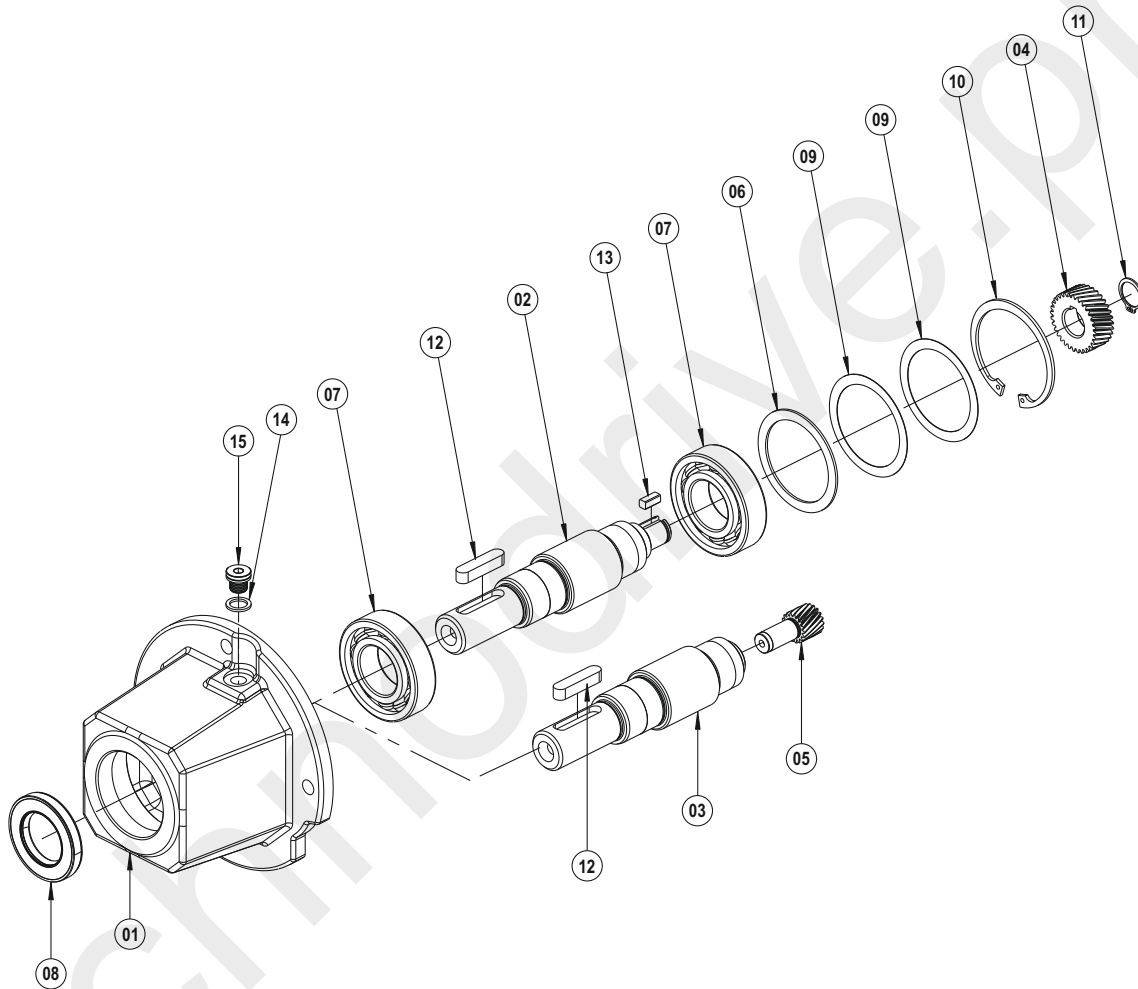

- | | | | | |
|-----------------------------------|---------------------------|----------------------------------|-------------------------------|-------------------------------|
| 01 Gehäuse | Gear Case | Ingranaggi Box | Corps | La caja de engranajes |
| 02 W Welle (Mit Passfeder) | W Shaft (With Key) | W Albero (Con chiavetta) | W Arbre (Avec clavette) | W Eje (Con clave) |
| 03 W Welle | W Shaft | W Albero | W Arbre | W Eje |
| 04 Antriebsritzel (Mit Passfeder) | Driving Pinion (With Key) | Ingresso Pignone (Con chiavetta) | Engrenage Z1 (Avec clavette) | Piñón de entrada (Con clave) |
| 05 Antriebsritzel | Driving Pinion | Ingresso Pignone | Engrenage Z1 | Piñón de entrada |
| 06 Distanzscheibe | Washer | Rondella | Rondelle | El apoyo a disco |
| 07 Kugellager | Bearing | Cuscinetto | Roulement à billes | Rodamiento de bolas |
| 08 Öldichtung | Oil Seal | Paraolio | Joint Huile | Sello de aceite |
| 09 Passscheibe (DIN 988) | Shim (DIN 988) | Shim | Rondelle d'ajustage (DIN 988) | Calce |
| 10 Sicherungsring (DIN 472) | Circlip (DIN 472) | Anello di sicurezza (DIN 472) | Circlip (DIN 472) | Anillo de seguridad (DIN 472) |
| 11 Sicherungsring (DIN 471) | Circlip (DIN 471) | Anello di sicurezza (DIN 471) | Circlip (DIN 471) | Anillo de seguridad (DIN 471) |
| 12 Passfeder (DIN 6885) | Key (DIN 6885) | Chiavetta (DIN 6885) | Clavette (DIN 6885) | Clave (DIN 6885) |
| 13 Passfeder (DIN 6885) | Key (DIN 6885) | Chiavetta (DIN 6885) | Clavette (DIN 6885) | Clave (DIN 6885) |
| 14 Distanzscheibe (DIN 7603) | Washer (DIN 7603) | Rondella (DIN 7603) | Rondelle (DIN 7603) | El apoyo a disco (DIN 7603) |
| 15 Ölstopfel (DIN 908) | Oil Plug (DIN 908) | Olio Tappo (DIN 908) | Bouchon d'huile (DIN 908) | Tapón (DIN 908) |

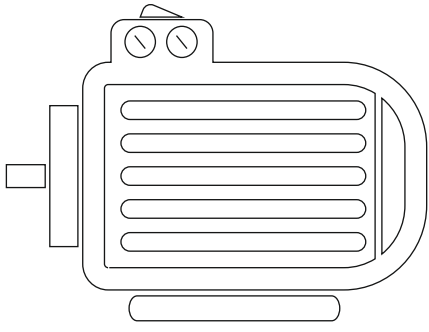

THREE PHASE MOTORS

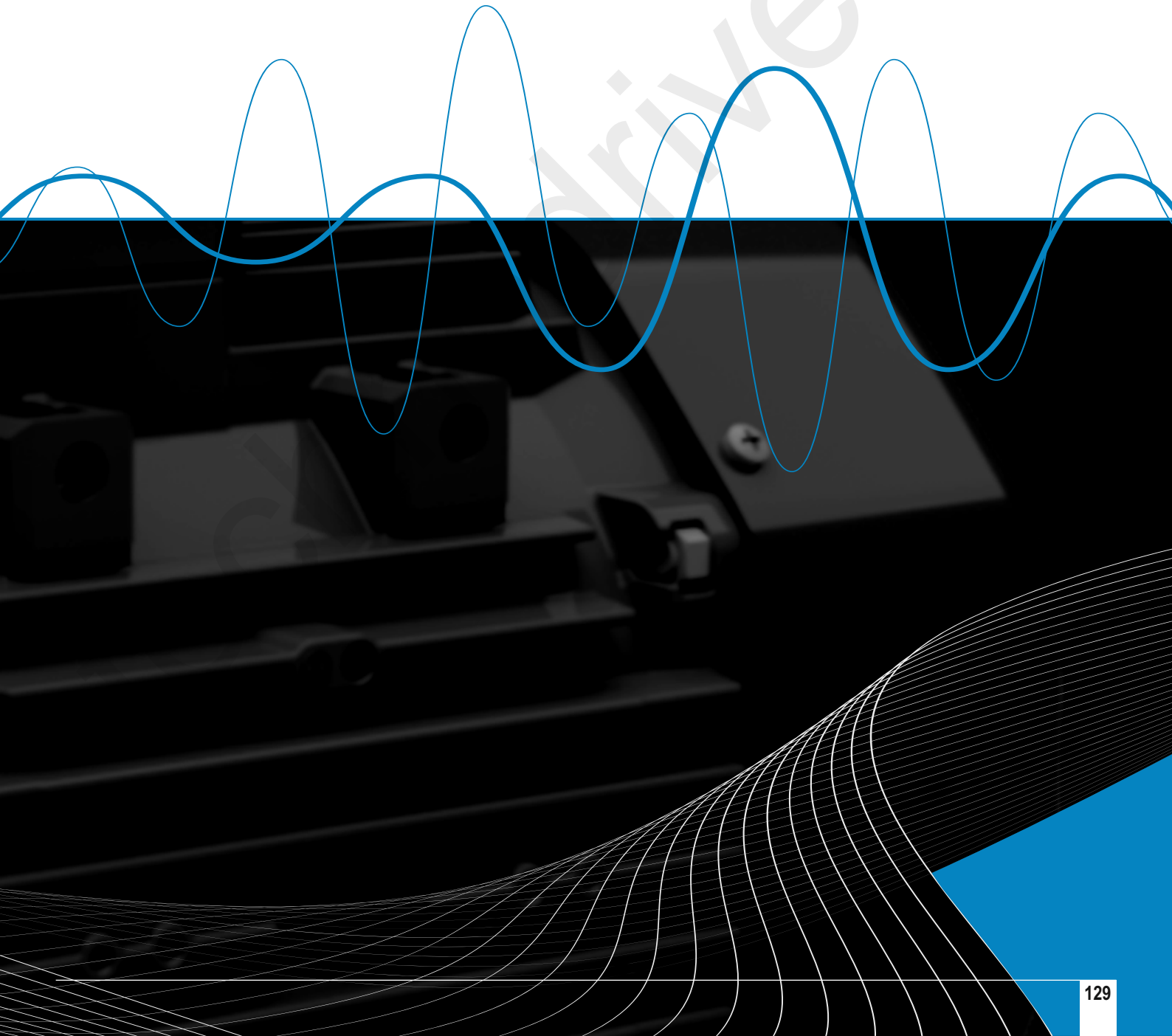

knoodrive.pro

IE3

techno.drawing.e.pro

ELECTRICAL CHARACTERISTICS AT 50 Hz

MOTOR TYPE	HOUSING TYPE	RATED VALUES					STARTING VALUES					Breakdown Torque Ratio Mk/ Mn	EFFICIENCY*			Cos φ	J kgm ²	Weight (B3) kg	Sound Pressure Level dBA**
		POWER		SPEED	CURRENT	TORQUE	CURRENT		TORQUE		η%								
		kW	HP	rpm	A	Nm	I_A / I_N	$I_Δ / I_N$	M_A / M_N	$M_Δ / M_N$	4/4		3/4	2/4					
2 pole 3000 rpm																			
230/400V	Q3H80M2C	Aluminium	0,75	1,0	2890	1,6	2,5	8,3	-	3,7	-	4,2	80,7	79,8	76,1	0,85	0,0014	13	57
	Q3H80M2D	Aluminium	1,1	1,5	2890	2,3	3,6	9,1	-	3,9	-	4,3	82,7	82,2	79,3	0,85	0,0017	13	57
	Q3H90L2C	Aluminium	1,5	2,0	2910	3,3	4,9	10,9	-	5,2	-	5,4	84,2	83,3	80,5	0,80	0,0023	16	62
	Q3H90L2D	Aluminium	2,2	3,0	2917	4,3	7,2	9,2	-	3,1	-	4,9	85,9	86,4	85,2	0,87	0,0028	19	62
	Q3H100L2D	Aluminium	3,0	4,0	2890	5,9	9,9	8,1	-	3,2	-	3,5	87,1	88,1	87,7	0,85	0,0031	25	66
400/690V	Q3H112M2C	Aluminium	4,0	5,5	2936	7,5	13,0	3,6	10,9	1,6	4,8	5,7	88,1	88,1	85,8	0,85	0,0064	29	68
	Q3H132S2C	Aluminium	5,5	7,5	2918	10,5	18,0	3,6	10,7	1,2	3,7	5,1	89,2	89,0	87,2	0,86	0,0077	37	69
	Q3H132S2D	Aluminium	7,5	10,0	2918	13,9	24,5	3,6	10,8	1,4	4,3	5,4	90,1	90,3	89,1	0,88	0,0093	43	69
	Q3H160M2C	Aluminium	11,0	15,0	2925	20,7	36,0	3,5	10,5	1,3	3,9	5,2	91,2	91,4	90,6	0,85	0,0352	65	70
	Q3H160M2DE	Aluminium	15,0	20,0	2930	27,9	48,9	3,5	10,5	1,2	3,7	5,2	91,9	91,3	89,8	0,84	0,0402	79	71
	Q3H160L2C	Aluminium	18,5	25,0	2960	32,8	59,9	3,6	10,8	1,1	3,4	4,8	92,4	92,5	91,6	0,89	0,0481	96	70
	Q3H180M2A	Aluminium	22,0	30,0	2961	39,1	70,7	3,5	10,5	1,1	3,2	5,2	92,7	92,5	91,3	0,87	0,0587	114	77
	Q3H200L2C	Aluminium	30,0	40,0	2955	50,3	97,0	3,5	10,5	1,0	3,0	4,5	93,3	93,2	92,2	0,92	0,1028	153	78
	Q3H200L2D	Aluminium	37,0	50,0	2960	61,9	119,4	3,3	9,9	1,0	2,9	4,4	93,7	94,4	94,0	0,92	0,1138	166	78
	Q3E225M2B	Aluminium	45,0	60,0	2965	77,1	144,9	2,8	8,6	0,9	2,4	3,8	94,0	93,7	92,2	0,85	0,2350	249	80
	Q3E250M2A	Aluminium	55,0	75,0	2970	92,1	176,7	2,7	8	0,8	2,5	3,1	94,3	94,1	92,9	0,92	0,50903	279	81
	Q3EP250M2C	Cast Iron	55,0	75,0	2982	93,8	176,1	2,3	7,0	0,9	2,7	3,4	94,3	94,0	92,6	0,90	0,4870	488	81
	Q3EP280M2C	Cast Iron	75,0	100,0	2975	124,9	240,7	2,8	8,4	0,7	2,2	4,4	94,7	94,2	93,1	0,92	0,5400	585	82
	Q3EP280M2D	Cast Iron	90,0	125,0	2975	150,7	288,9	2,8	8,6	0,8	2,4	5,4	95,0	94,7	93,7	0,93	0,6450	596	82
	Q3EP315S2C	Cast Iron	110,0	127,0	2,983	187	358	2,4	7,2	0,6	1,7	2,6	95,2	95,2	94,0	0,89	2,19900	963	83
	Q3EP315M2B	Cast Iron	132,0	152,0	2,983	224	418	2,5	7,5	0,6	1,8	2,6	95,4	95,4	94,4	0,89	2,37790	1.007	83
	Q3EP315L2A	Cast Iron	160,0	184,0	2,983	271	513	2,5	7,5	0,6	1,8	2,6	95,6	95,6	94,4	0,89	2,62170	1.065	83
	Q3EP315L2C	Cast Iron	200,0	230,0	2,983	339	641	2,5	7,5	0,6	1,9	2,6	95,8	95,8	94,9	0,89	2,90860	1.180	83
	Q3EP355M2C	Cast Iron	250,0	280,0	2,983	419	800	2,4	7,3	0,6	1,7	2,5	95,8	95,8	94,7	0,90	3,81300	1.612	91
	Q3EP355L2B	Cast Iron	315,0	353,0	2,984	527	1.008	2,4	7,3	0,6	1,8	2,5	95,8	95,7	94,4	0,90	4,52000	1.771	91
Q3EP355L2C	Cast Iron	355,0	398,0	2,981	594	1.137	2,6	7,9	0,7	2,2	2,5	95,8	95,8	95,0	0,90	5,58000	2.002	91	
4 pole 1500 rpm																			
230/400V	Q3H80M4D	Aluminium	0,75	1,0	1445	1,7	5,0	6,7	-	2,8	-	3,4	82,5	83,2	80,6	0,77	0,00261	13	52
	Q3H90L4C	Aluminium	1,1	1,5	1447	2,6	7,3	7,2	-	3,1	-	3,7	82,7	82,4	89,5	0,74	0,00328	15	54
	Q3H90L4D	Aluminium	1,5	2,0	1449	3,5	9,9	8,1	-	3,6	-	4,2	85,3	85,0	82,1	0,76	0,00526	20	53
	Q3H100L4C	Aluminium	2,2	3,0	1443	4,9	14,6	9,5	-	5,0	-	5,5	86,7	84,3	80,6	0,75	0,00690	25	55
	Q3H100L4D	Aluminium	3,0	4,0	1446	6,2	19,9	8,4	-	3,3	-	3,8	87,7	88,0	87,0	0,81	0,01059	31	56
400/690V	Q3H112M4D	Aluminium	4,0	5,5	1452	8,2	26,5	3,0	9,1	1,1	3,3	4,1	88,6	88,8	87,3	0,80	0,01383	32	54
	Q3H132S4B	Aluminium	5,5	7,5	1467	10,6	35,8	2,8	8,5	0,7	2,0	3,8	89,6	89,1	87,6	0,84	0,03560	53	60
	Q3H132M4D	Aluminium	7,5	10,0	1467	15,2	48,8	2,7	8,2	0,8	2,3	3,8	90,4	90,7	89,6	0,80	0,04030	58	60
	Q3H160M4C	Aluminium	11,0	15,0	1470	21,0	71,3	2,7	8,0	0,7	2,1	3,8	91,4	91,5	90,4	0,83	0,05940	84	63
	Q3H160L4B	Aluminium	15,0	20,0	1477	30,9	97,1	2,6	7,8	0,9	2,8	3,3	92,1	92,0	90,8	0,76	0,09005	101	62
	Q3H180M4B	Aluminium	18,5	25,0	1474	39,5	119,9	2,5	7,4	0,8	2,3	3,5	92,6	91,9	91,2	0,74	0,11398	118	67
	Q3H180L4B	Aluminium	22,0	30,0	1485	41,6	141,7	3,1	9,2	0,9	2,8	3,6	93,0	93,1	92,3	0,83	0,18660	158	68
	Q3H200L4D	Aluminium	30,0	40,0	1475	54,8	195,5	2,7	8,0	0,8	2,5	3,1	93,6	94,6	94,8	0,85	0,22166	194	68
	Q3E225M4B	Aluminium	37,0	50,0	1485	68,6	237,9	2,9	8,8	1,0	3,1	3,7	93,9	93,8	92,6	0,84	0,36400	280	71
	Q3E225M4C	Aluminium	45,0	60,0	1485	83,1	289,4	3,0	9,2	1,0	3,1	3,7	94,2	94,0	93,3	0,83	0,43500	276	71
	Q3E250M4B	Cast Iron	55,0	75,0	1487	106,9	353,2	3,0	9,2	1,0	3,1	3,7	94,6	94,4	93,5	0,79	0,90782	506	72
	Q3EP280M4C	Cast Iron	75,0	100,0	1485	138,9	482,3	2,6	7,8	1,0	3,0	3,2	95,0	94,8	94,0	0,82	1,06100	638	73
	Q3EP280M4D	Cast Iron	90,0	125,0	1485	163,5	578,7	2,6	7,9	1,0	3,0	3,2	95,2	95,0	93,9	0,86	1,14760	653	73
	Q3EP315S4C	Cast Iron	110,0	127,0	1,489	194	705	2,5	7,5	0,7	2,0	2,5	95,4	95,4	94,7	0,86	3,46500	867	70
	Q3EP315M4B	Cast Iron	132,0	152,0	1,489	232	846	2,5	7,6	0,7	2,1	2,5	95,6	95,6	95,0	0,86	3,96600	993	70
	Q3EP315L4A	Cast Iron	160,0	184,0	1,489	274	1.026	2,5	7,6	0,7	2,2	2,5	95,8	95,8	95,4	0,88	4,88320	1.165	70
	Q3EP315L4C	Cast Iron	200,0	230,0	1,489	346	1.282	2,7	8,2	0,7	2,2	2,5	96,0	96,0	95,5	0,87	5,23440	1.223	70
	Q3EP355M4C	Cast Iron	250,0	280,0	1,491	422	1.601	2,5	7,5	0,6	1,9	2,4	96,0	96,0	95,5	0,89	9,30600	1.692	82
	Q3EP355L4B	Cast Iron	315,0	353,0	1,491	532	2.017	2,5	7,5	0,6	1,9	2,4	96,0	96,0	95,5	0,89	10,06700	1.879	82
	Q3EP355L4C	Cast Iron	355,0	398,0	1,491	600	2.273	2,5	7,5	0,7	2,0	2,3	96,0	96,0	95,5	0,89	11,90000	1.953	82

* According to IEC 60034-2-1

** The sound pressure measurements are taken 1m away from the motor

*** Tolerance +3 dBA

MOTOR TYPE	HOUSING TYPE	RATED VALUES						STARTING VALUES				Breakdown Torque Ratio Mk/ Mn	EFFICIENCY*			Cos φ	J kgm ²	Weight (B3) kg	Sound Pressure Level dBA**
		POWER		SPEED	CURRENT	TORQUE	CURRENT		TORQUE		η%								
		kW	HP	rpm	A	Nm	I_A / I_N	$I_Δ$	M_A / M_N	$M_Δ$	4/4		3/4	2/4					
6 pole 1000 rpm																			
230/400V	Q3H90L6C	Aluminium	0,75	1,0	950	2,1	7,6	4,9	-	2,5	-	3,0	78,9	78,4	74,9	0,67	0,00460	18	53
	Q3H90L6D	Aluminium	1,1	1,5	950	3,0	11,1	4,5	-	2,6	-	2,9	81,0	80,6	78,3	0,67	0,00528	20	53
	Q3H100L6D	Aluminium	1,5	2,0	960	4,1	14,9	4,8	-	2,6	-	3,0	82,5	81,7	78,2	0,65	0,01059	26	55
	Q3H112M6D	Aluminium	2,2	3,0	957	5,2	22,0	4,9	-	2,7	-	3,0	84,3	84,6	83,7	0,71	0,01383	32	57
400/690V	Q3H132S6A	Aluminium	3,0	4,0	978	7,3	29,3	1,9	5,7	0,6	2,0	2,5	85,6	85,2	82,8	0,68	0,03560	53	61
	Q3H132M6A	Aluminium	4,0	5,5	975	9,1	39,2	2,0	6,0	0,7	2,2	2,6	86,8	85,7	82,8	0,72	0,04030	58	60
	Q3H132M6B	Aluminium	5,5	7,5	971	12,0	54,1	2,1	6,3	0,7	2,1	2,6	88,0	87,6	85,3	0,75	0,05940	82	60
	Q3H160M6C	Aluminium	7,5	10,0	976	16,5	73,4	2,0	6,0	0,7	2,2	3,0	89,1	89,0	88,0	0,73	0,07540	88	62
	Q3H160L6D	Aluminium	11,0	15,0	974	24,2	107,8	2,1	6,3	0,7	2,2	3,0	90,3	90,1	89,3	0,73	0,09000	101	62
	Q3H180L6B	Aluminium	15,0	20,0	980	32,2	146,2	2,2	6,6	0,7	2,1	2,9	91,2	90,9	88,7	0,75	0,18660	155	68
	Q3H200L6C	Aluminium	18,5	25,0	981	40,3	180,1	2,3	6,9	0,6	1,9	2,7	91,7	91,6	91,3	0,72	0,23286	194	69
	Q3H200L6D	Aluminium	22,0	30,0	982	50,5	213,9	2,9	5,0	0,6	1,9	2,2	92,2	92,2	91,6	0,69	0,22166	193	69
	Q3E225M6C	Aluminium	30,0	40,0	975	59,1	293,8	1,9	6,1	0,6	1,8	2,5	92,9	92,8	91,8	0,80	0,52900	238	71

* According to IEC 60034-2-1

** The sound pressure measurements are taken 1m away from the motor

*** Tolerance +3 dBA

DIMENSION - B3

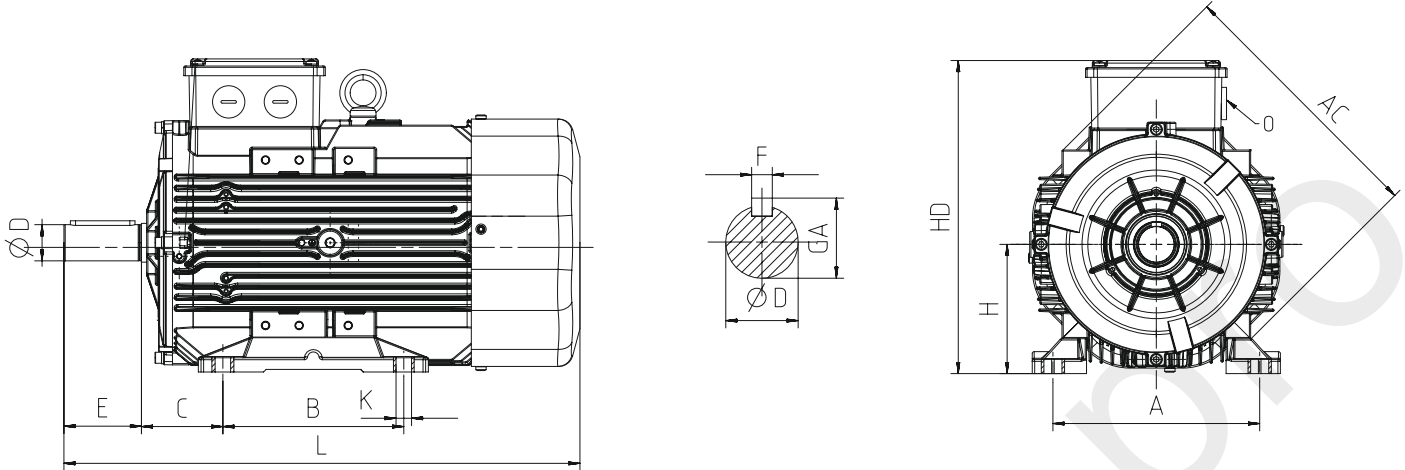

Power (kW)	Number of Poles	Motor Type	Housing Type	Main Dimensions			Foot Mounted Motors						Shaft				Bearing		Seal	
				AC	L	O	B	A	H	HD	K	C	D ⁽¹⁾	E	GA	F ⁽²⁾	Drive Side	Non drive Side	Drive Side	Non drive Side
0,75	2	Q3H80M2C	Aluminium	158	268	1xM20	100	125	80	216	10	50	19	40	21,5	6	6204-ZZ	6204-ZZ	20*30*7	20*30*7
0,75	4	Q3H80M4D	Aluminium	158	268	1xM20	100	125	80	216	10	50	19	40	21,5	6	6204-ZZ	6204-ZZ	20*30*7	20*30*7
0,75	6	Q3H90L6C	Aluminium	172	344	1xM25	100-125	140	90	223	10	56	24	50	27,0	8	6305-ZZ	6205-ZZ	25*40*7	25*40*7
1,1	2	Q3H80M2D	Aluminium	158	268	1xM20	100	125	80	216	10	50	19	40	21,5	6	6204-ZZ	6204-ZZ	20*30*7	20*30*7
1,1	4	Q3H90L4C	Aluminium	158	303	1xM25	100-125	140	90	213	10	56	24	50	27,0	8	6305-ZZ	6204-ZZ	25*40*7	20*30*7
1,1	6	Q3H90L6D	Aluminium	172	344	1xM25	100-125	140	90	223	10	56	24	50	27,0	8	6305-ZZ	6205-ZZ	25*40*7	25*40*7
1,5	2	Q3H90L2C	Aluminium	158	303	1xM25	100-125	140	90	213	10	56	24	50	27,0	8	6305-ZZ	6204-ZZ	25*40*7	20*30*7
1,5	4	Q3H90L4D	Aluminium	172	344	1xM25	100-125	140	90	223	10	56	24	50	27,0	8	6305-ZZ	6205-ZZ	25*40*7	25*40*7
1,5	6	Q3H100L6D	Aluminium	191	400	1xM25	140	160	100	243	12	63	28	60	31,0	8	6306-ZZ	6205-ZZ	30*47*7	30*47*7
2,2	2	Q3H90L2D	Aluminium	172	344	1xM25	100-125	140	90	223	10	56	24	50	27,0	8	6305-ZZ	6205-ZZ	25*40*7	25*40*7
2,2	4	Q3H100L4C	Aluminium	172	384	1xM25	140	160	100	233	12	63	28	60	31,0	8	6306-ZZ	6205-ZZ	30*47*7	25*40*7
2,2	6	Q3H112M6D	Aluminium	210	396	1xM25	140	190	112	265	12	70	28	60	31,0	8	6306-ZZ	6206-ZZ	30*47*7	30*47*7
3	2	Q3H100L2D	Aluminium	172	349	1xM25	140	160	100	233	12	63	28	60	31,0	8	6306-ZZ	6205-ZZ	30*47*7	25*40*7
3	4	Q3H100L4D	Aluminium	191	400	1xM25	140	160	100	243	12	63	28	60	31,0	8	6306-ZZ	6205-ZZ	30*47*7	30*47*7
3	6	Q3H132S6A	Aluminium	260	481	1xM32	140-178	216	132	312	12	89	38	80	41,0	10	6208-ZZ	6208-ZZ	40*62*10	40*62*10
4	2	Q3H112M2C	Aluminium	191	400	1xM25	140	190	112	254	12	70	28	60	31,0	8	6306-ZZ	6205-ZZ	30*47*7	25*40*7
4	4	Q3H112M4D	Aluminium	210	396	1xM25	140	190	112	265	12	70	28	60	31,0	8	6306-ZZ	6206-ZZ	30*47*7	30*47*7
4	6	Q3H132M6A	Aluminium	260	481	1xM32	140-178	216	132	312	12	89	38	80	41,0	10	6208-ZZ	6208-ZZ	40*62*10	40*62*10
5,5	2	Q3H132S2C	Aluminium	210	422	1xM25	140-178	216	132	283	12	89	38	80	41,0	10	6208-ZZ	6206-ZZ	40*62*10	30*47*7
5,5	4	Q3H132S4B	Aluminium	260	481	1xM32	140-178	216	132	312	12	89	38	80	41,0	10	6208-ZZ	6208-ZZ	40*62*10	40*62*10
5,5	6	Q3H132M6B	Aluminium	260	481	1xM32	140-178	216	132	312	12	89	38	80	41,0	10	6208-ZZ	6208-ZZ	40*62*10	40*62*10
7,5	2	Q3H132S2D	Aluminium	210	448	1xM25	140-178	216	132	283	12	89	38	80	41,0	10	6208-ZZ	6206-ZZ	40*62*10	30*47*7
7,5	4	Q3H132M4D	Aluminium	260	481	1xM32	140-178	216	132	312	12	89	38	80	41,0	10	6208-ZZ	6208-ZZ	40*62*10	40*62*10
7,5	6	Q3H160M6C	Aluminium	305	591	1xM32	210-254	254	160	368	14,5	108	42	110	45,0	12	6309-ZZ	6209-ZZ	45*72*10	45*72*10
11	2	Q3H160M2C	Aluminium	260	520	1xM32	210-254	254	160	351	14,5	108	42	110	45,0	12	6309-ZZ	6208-ZZ	45*72*10	40*62*10
11	4	Q3H160M4C	Aluminium	260	578	1xM32	210-254	254	160	351	14,5	108	42	110	45,0	12	6309-ZZ	6208-ZZ	45*72*10	40*62*10
11	6	Q3H160L6D	Aluminium	305	591	1xM32	210-254	254	160	368	14,5	108	42	110	45,0	12	6309-ZZ	6209-ZZ	45*72*10	45*72*10
15	2	Q3H160M2DE	Aluminium	260	580	1xM32	210-254	254	160	351	14,5	108	42	110	45,0	12	6309-ZZ	6208-ZZ	45*72*10	40*62*10
15	4	Q3H160L4B	Aluminium	305	591	1xM32	210-254	254	160	368	14,5	108	42	110	45,0	12	6309-ZZ	6209-ZZ	45*72*10	45*72*10
15	6	Q3H180L6B	Aluminium	349	696	1xM40	241-279	279	180	437	14,5	121	48	110	51,5	14	6310-ZZ	6310-ZZ	50*80*10	50*80*10

(1) Tolerance DIN EN 50347 "j6" up to 28mm, "k6" above 28mm

(2) According to DIN 6885

Power (kW)	Number of Poles	Motor Type	Housing Type	Main Dimensions			Foot Mounted Motors						Shaft				Bearing		Seal	
				AC	L	O	B	A	H	HD	K	C	D ⁽¹⁾	E	GA	F ⁽²⁾	Drive Side	Non drive Side	Drive Side	Non drive Side
18,5	2	Q3H160L2C	Aluminium	305	591	1xM32	210-254	254	160	368	14,5	108	42	110	45,0	12	6309-ZZ	6209-ZZ	45*72*10	45*72*10
18,5	4	Q3H180M4B	Aluminium	305	596	1xM32	241-279	279	180	398	14,5	121	48	110	51,5	14	6310-ZZ	6209-ZZ	50*80*10	45*72*10
18,5	6	Q3H200L6C	Aluminium	349	750	1xM50	305	318	200	455	18,5	133	55	110	59,0	16	6312-ZZ	6310-ZZ	60*90*10	60*90*10
22	2	Q3H180M2B	Aluminium	305	596	1xM32	241-279	279	180	398	14,5	121	48	110	51,5	14	6310-ZZ	6209-ZZ	50*80*10	45*72*10
22	4	Q3H180L4B	Aluminium	349	696	1xM40	241-279	279	180	437	14,5	121	48	110	51,5	14	6310-ZZ	6310-ZZ	50*80*10	50*80*10
22	6	Q3H200L6D	Aluminium	349	759	1xM50	267-305	318	200	455	18,5	133	55	110	59,0	16	6312-ZZ	6310-ZZ	60*90*10	60*90*10
30	2	Q3H200L2C	Aluminium	349	706	1xM50	267-305	318	200	455	18,5	133	55	110	59,0	16	6312-ZZ	6310-ZZ	60*90*10	60*90*10
30	4	Q3H200L4D	Aluminium	349	759	1xM50	267-305	318	200	455	18,5	133	55	110	59,0	16	6312-ZZ	6310-ZZ	60*90*10	60*90*10
30	6	Q3E225M6C	Aluminium	456	765	1xM50	286-311	356	225	485	18,5	149	60	140	64,0	18	6313-ZZ	6313-ZZ	65*100*13	65*100*13
37	2	Q3H200L2D	Aluminium	349	706	1xM50	305	318	200	455	18,5	133	55	110	59,0	16	6312-ZZ	6310-ZZ	60*90*10	60*90*10
37	4	Q3E225M4B	Aluminium	456	765	1xM50	286-311	356	225	485	18,5	149	60	140	64,0	18	6313-ZZ	6313-ZZ	65*100*13	65*100*13
45	2	Q3E225M2B	Aluminium	456	735	1xM50	286-311	356	225	485	18,5	149	55	110	59,0	16	6313-ZZ	6313-ZZ	65*100*13	65*100*13
45	4	Q3E225M4C	Aluminium	456	765	1xM50	286-311	356	225	485	18,5	149	60	140	64,0	18	6313-ZZ	6313-ZZ	65*100*13	65*100*13
55	2	Q3E250M2A	Aluminium	527	886	2xM50	349	406	250	615	24	149	60	140	64,0	18	6315-ZZ	6313-ZZ	75*112*12	65*100*13
55	2	Q3EP250M2C	Cast Iron	489	893	1xM50	349	406	250	616	24	149	60	140	69,0	18	6316	6316	80*100*10	80*100*10
55	4	Q3E250M4B	Cast Iron	489	893	1xM50	349	406	250	616	24	149	65	140	69,0	18	6316	6316	80*100*10	80*100*10
75	2	Q3EP280M2C	Cast Iron	489	1025	1xM50	419	457	280	647	24	190	65	140	69,0	18	6316	6316	80*100*10	80*100*10
75	4	Q3EP280M4C	Cast Iron	489	1025	1xM50	419	457	280	647	24	190	75	140	79,5	20	6316	6316	80*100*10	80*100*10
90	2	Q3EP280M2D	Cast Iron	489	1025	1xM50	419	457	280	647	24	190	65	140	69,0	18	6316	6316	80*100*10	80*100*10
90	4	Q3EP280M4D	Cast Iron	489	1025	1xM50	419	457	280	647	24	190	75	140	79,5	20	6316	6316	80*100*10	80*100*10
110	2	Q3EP315S2C	Cast Iron	652	1176	2xM63	406	508	315	833	28	216	65	140	69	18	6316	6316	80*100*5.5	80*100*5.5
110	4	Q3EP315S4C	Cast Iron	652	1206	2xM63	406	508	315	833	28	216	80	170	85	22	6319	6319	95*115*5.5	95*115*5.5
132	2	Q3EP315M2B	Cast Iron	652	1176	2xM63	457	508	315	833	28	216	65	140	69	18	6316	6316	80*100*5.5	80*100*5.5
132	4	Q3EP315M4B	Cast Iron	652	1206	2xM63	457	508	315	833	28	216	80	170	85	22	6319	6319	95*115*5.5	95*115*5.5
160	2	Q3EP315L2A	Cast Iron	652	1287	2xM63	508	508	315	833	28	216	65	140	69	18	6316	6316	80*100*5.5	80*100*5.5
160	4	Q3EP315L4A	Cast Iron	652	1317	2xM63	508	508	315	833	28	216	80	170	85	22	6319	6319	95*115*5.5	95*115*5.5
200	2	Q3EP315L2C	Cast Iron	652	1287	2xM63	508	508	315	833	28	216	65	140	69	18	6316	6316	80*100*5.5	80*100*5.5
200	4	Q3EP315L4C	Cast Iron	652	1317	2xM63	508	508	315	833	28	216	80	170	85	22	6319	6319	95*115*5.5	95*115*5.5
250	2	Q3EP355M2C	Cast Iron	762	1512	4xM63	560	610	355	997	28	254	75	140	80	20	6317	6317	85*105*5.5	85*105*5.5
250	4	Q3EP355M4C	Cast Iron	762	1542	4xM63	560	610	355	997	28	254	95	170	100	25	6322	6322	110*130*5.5	110*130*5.5
315	2	Q3EP355L2B	Cast Iron	762	1512	4xM63	630	610	355	997	28	254	75	140	80	20	6317	6317	85*105*5.5	85*105*5.5
315	4	Q3EP355L4B	Cast Iron	762	1542	4xM63	630	610	355	997	28	254	95	170	100	25	6322	6322	110*130*5.5	110*130*5.5
355	2	Q3EP355L2C	Cast Iron	762	1512	4xM63	630	610	355	997	28	254	75	140	80	20	6317	6317	85*105*5.5	85*105*5.5
355	4	Q3EP355L4C	Cast Iron	762	1542	4xM63	630	610	355	997	28	254	95	170	100	25	6322	6322	110*130*5.5	110*130*5.5

(1) Tolerance DIN EN 50347 "j6" up to 28mm, "k6" above 28mm

(2) According to DIN 6885

DIMENSION - B5, B35

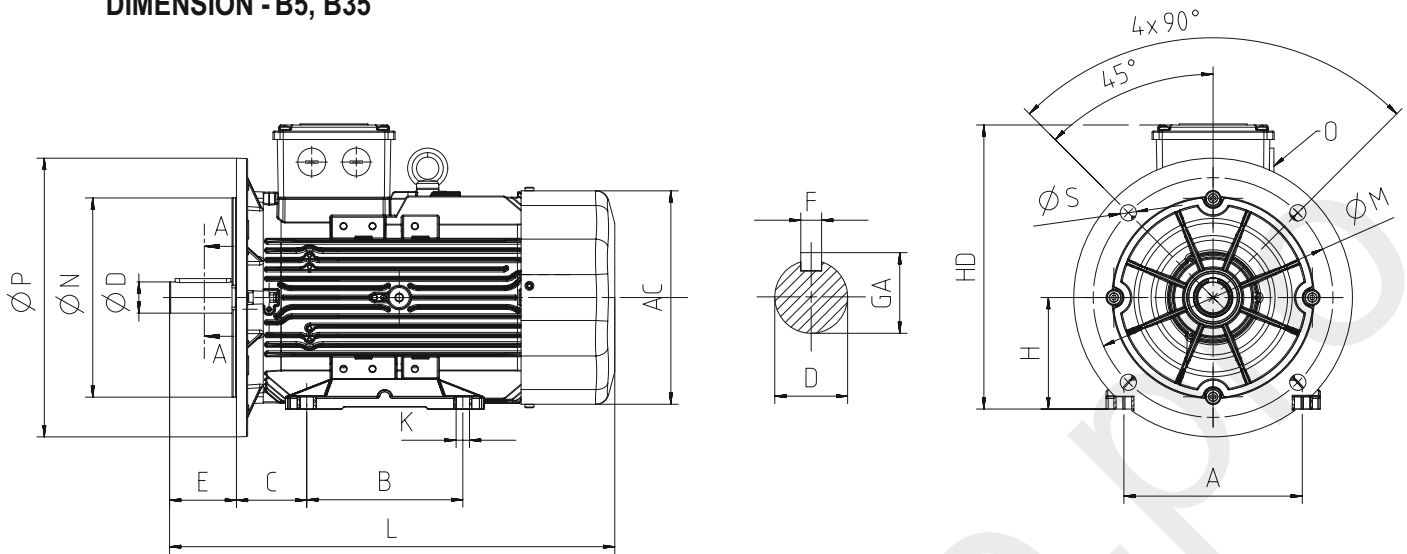

Power (kW)	Number of Poles	Motor Type	Housing Type	Main Dimensions			Foot Mounted Motors					Shaft				Bearing		Seal		Flange (FA) (B5)				
				AC	L	O	B	A	H	HD	K	D ⁽¹⁾	E	GA	F ⁽²⁾	Drive Side	Non drive Side	Drive Side	Non drive Side	P	N ⁽³⁾	M	R	S
0,75	2	Q3H80M2C	Aluminium	158	268	1xM20	100	125	80	216	10	19	40	21,5	6	6204-ZZ	6204-ZZ	20*30*7	20*30*7	200	130	165	-	12
0,75	4	Q3H80M4D	Aluminium	158	268	1xM20	100	125	80	216	10	19	40	21,5	6	6204-ZZ	6204-ZZ	20*30*7	20*30*7	200	130	165	-	12
0,75	6	Q3H90L6C	Aluminium	172	344	1xM25	100-125	140	90	223	10	24	50	27,0	8	6305-ZZ	6205-ZZ	25*40*7	25*40*7	200	130	165	-	12
1,1	2	Q3H80M2D	Aluminium	158	268	1xM20	100	125	80	216	10	19	40	21,5	6	6204-ZZ	6204-ZZ	20*30*7	20*30*7	200	130	165	-	12
1,1	4	Q3H90L4C	Aluminium	158	303	1xM25	100-125	140	90	213	10	24	50	27,0	8	6305-ZZ	6204-ZZ	25*40*7	20*30*7	200	130	165	-	12
1,1	6	Q3H90L6D	Aluminium	172	344	1xM25	100-125	140	90	223	10	24	50	27,0	8	6305-ZZ	6205-ZZ	25*40*7	25*40*7	200	130	165	-	12
1,5	2	Q3H90L2C	Aluminium	158	303	1xM25	100-125	140	90	213	10	24	50	27,0	8	6305-ZZ	6204-ZZ	25*40*7	20*30*7	200	130	165	-	12
1,5	4	Q3H90L4D	Aluminium	172	344	1xM25	100-125	140	90	223	10	24	50	27,0	8	6305-ZZ	6205-ZZ	25*40*7	25*40*7	200	130	165	-	12
1,5	6	Q3H100L6D	Aluminium	191	400	1xM25	140	160	100	243	12	28	60	31,0	8	6306-ZZ	6205-ZZ	30*47*7	30*47*7	250	180	215	-	14,5
2,2	2	Q3H90L2D	Aluminium	172	344	1xM25	100-125	140	90	223	10	24	50	27,0	8	6305-ZZ	6205-ZZ	25*40*7	25*40*7	200	130	165	-	12
2,2	4	Q3H100L4C	Aluminium	172	384	1xM25	140	160	100	233	12	28	60	31,0	8	6306-ZZ	6205-ZZ	30*47*7	25*40*7	250	180	215	-	14,5
2,2	6	Q3H112M6D	Aluminium	210	396	1xM25	140	190	112	265	12	28	60	31,0	8	6306-ZZ	6206-ZZ	30*47*7	30*47*7	250	180	215	-	14,5
3	2	Q3H100L2D	Aluminium	172	349	1xM25	140	160	100	233	12	28	60	31,0	8	6306-ZZ	6205-ZZ	30*47*7	25*40*7	250	180	215	-	14,5
3	4	Q3H100L4D	Aluminium	191	400	1xM25	140	160	100	243	12	28	60	31,0	8	6306-ZZ	6205-ZZ	30*47*7	30*47*7	250	180	215	-	14,5
3	6	Q3H132S6A	Aluminium	260	481	1xM32	140-178	216	132	312	12	38	80	41,0	10	6208-ZZ	6208-ZZ	40*62*10	40*62*10	300	230	265	-	14,5
4	2	Q3H112M2C	Aluminium	191	399	1xM25	140	190	112	254	12	28	60	31,0	8	6306-ZZ	6205-ZZ	30*47*7	25*40*7	250	180	215	-	14,5
4	4	Q3H112M4D	Aluminium	210	396	1xM25	140	190	112	265	12	28	60	31,0	8	6306-ZZ	6206-ZZ	30*47*7	30*47*7	250	180	215	-	14,5
4	6	Q3H132M6A	Aluminium	260	481	1xM32	140-178	216	132	312	12	38	80	41,0	10	6208-ZZ	6208-ZZ	40*62*10	40*62*10	300	230	265	-	14,5
5,5	2	Q3H132S2C	Aluminium	210	422	1xM25	140-178	216	132	283	12	38	80	41,0	10	6208-ZZ	6206-ZZ	40*62*10	30*47*7	300	230	265	-	14,5
5,5	4	Q3H132S4B	Aluminium	260	481	1xM32	140-178	216	132	312	12	38	80	41,0	10	6208-ZZ	6208-ZZ	40*62*10	40*62*10	300	230	265	-	14,5
5,5	6	Q3H132M6B	Aluminium	260	481	1xM32	140-178	216	132	312	12	38	80	41,0	10	6208-ZZ	6208-ZZ	40*62*10	40*62*10	300	230	265	-	14,5
7,5	2	Q3H132S2D	Aluminium	210	448	1xM25	140-178	216	132	283	12	38	80	41,0	10	6208-ZZ	6206-ZZ	40*62*10	30*47*7	300	230	265	-	14,5
7,5	4	Q3H132M4D	Aluminium	260	481	1xM32	140-178	216	132	312	12	38	80	41,0	10	6208-ZZ	6208-ZZ	40*62*10	40*62*10	300	230	265	-	14,5
7,5	6	Q3H160M6C	Aluminium	305	591	1xM32	210-254	254	160	368	14,5	42	110	45,0	12	6309-ZZ	6209-ZZ	45*72*10	45*72*10	350	250	300	-	18,5
11	2	Q3H160M2C	Aluminium	260	520	1xM32	210-254	254	160	351	14,5	42	110	45,0	12	6309-ZZ	6208-ZZ	45*72*10	40*62*10	350	250	300	-	18,5
11	4	Q3H160M4C	Aluminium	260	580	1xM32	210-254	254	160	351	14,5	42	110	45,0	12	6309-ZZ	6208-ZZ	45*72*10	40*62*10	350	250	300	-	18,5
11	6	Q3H160L6D	Aluminium	305	591	1xM32	210-254	254	160	368	14,5	42	110	45,0	12	6309-ZZ	6209-ZZ	45*72*10	45*72*10	350	250	300	-	18,5
15	2	Q3H160M2DE	Aluminium	260	580	1xM32	210-254	254	160	351	14,5	42	110	45,0	12	6309-ZZ	6208-ZZ	45*72*10	40*62*10	350	250	300	-	18,5
15	4	Q3H160L4B	Aluminium	305	591	1xM32	210-254	254	160	368	14,5	42	110	45,0	12	6309-ZZ	6209-ZZ	45*72*10	45*72*10	350	250	300	-	18,5
15	6	Q3H180L6B	Aluminium	349	696	1xM40	241-279	279	180	437	14,5	48	110	51,5	14	6310-ZZ	6310-ZZ	50*80*10	50*80*10	350	250	300	-	18,5

(1) Tolerance DIN EN 50347 "j6" up to 28mm, "k6" above 28mm

(2) According to DIN 6885

(3) Tolerance DIN EN 50347 "j6"

Power (kW)	Number of Poles	Motor Type	Housing Type	Main Dimensions			Foot Mounted Motors					Shaft				Bearing		Seal		Flange (FA) (B5)				
				AC	L	O	B	A	H	HD	K	D ⁽¹⁾	E	GA	F ⁽²⁾	Drive Side	Non drive Side	Drive Side	Non drive Side	P	N ⁽³⁾	M	R	S
18,5	4	Q3H180M4B	Aluminium	305	596	1xM32	241-279	279	180	398	14,5	48	110	51,5	14	6310-ZZ	6209-ZZ	50*80*10	45*72*10	350	250	300	-	18,5
18,5	6	Q3H200L6C	Aluminium	349	750	1xM50	305	318	200	455	18,5	55	110	59,0	16	6312-ZZ	6310-ZZ	60*90*10	60*90*10	400	300	350	-	18,5
22	2	Q3H180M2A	Aluminium	305	596	1xM32	241-279	279	180	398	14,5	48	110	51,5	14	6310-ZZ	6209-ZZ	50*80*10	45*72*10	350	250	300	-	18,5
22	4	Q3H180L4B	Aluminium	349	696	1xM40	241-279	279	180	437	14,5	48	110	51,5	14	6310-ZZ	6310-ZZ	50*80*10	50*80*10	350	250	300	-	18,5
22	6	Q3H200L6D	Aluminium	349	759	1xM50	305	318	200	455	18,5	55	110	59,0	16	6312-ZZ	6310-ZZ	60*90*10	60*90*10	400	300	350	-	18,5
30	2	Q3H200L2C	Aluminium	349	706	1xM50	305	318	200	455	18,5	55	110	59,0	16	6312-ZZ	6310-ZZ	60*90*10	60*90*10	400	300	350	-	18,5
30	4	Q3H200L4D	Aluminium	349	759	1xM50	305	318	200	455	18,5	55	110	59,0	16	6312-ZZ	6310-ZZ	60*90*10	60*90*10	400	300	350	-	18,5
30	6	Q3E225M6C	Aluminium	456	765	1xM50	286-311	356	225	485	18,5	60	140	64,0	18	6313-ZZ	6313-ZZ	65*100*13	65*100*13	450	350	400	-	18,5
37	2	Q3H200L2D	Aluminium	349	706	1xM50	305	318	200	455	18,5	55	110	59,0	16	6312-ZZ	6310-ZZ	60*90*10	60*90*10	400	300	350	-	18,5
37	4	Q3E225M4B	Aluminium	456	765	1xM50	286-311	356	225	485	18,5	60	140	64,0	18	6313-ZZ	6313-ZZ	65*100*13	65*100*13	450	350	400	-	18,5
45	2	Q3E225M2B	Aluminium	456	735	1xM50	286-311	356	225	485	18,5	55	110	59,0	16	6313-ZZ	6313-ZZ	65*100*13	65*100*13	450	350	400	-	18,5
45	4	Q3E225M4C	Aluminium	456	765	1xM50	286-311	356	225	485	18,5	60	140	64,0	18	6313-ZZ	6313-ZZ	65*100*13	65*100*13	450	350	400	-	18,5
55	2	Q3E250M2A	Aluminium	527	886	2*M50	349	406	250	615	24	60	140	64,0	18	6315-ZZ	6313-ZZ	75*112*12	65*100*13	550	450	500	-	18,5
55	2	Q3EP250M2C	Cast Iron	489	893	1xM50	349	406	250	616	24	60	140	69,0	18	6316	6316	80*100*10	80*100*10	550	450	500	-	18,5
55	4	Q3E250M4B	Cast Iron	489	893	1xM50	349	406	250	616	24	65	140	69,0	18	6316	6316	80*100*10	80*100*10	550	450	500	-	18,5
75	2	Q3EP280M2C	Cast Iron	489	1025	1xM50	368-419	457	280	647	24	65	140	69,0	18	6316	6316	80*100*10	80*100*10	550	450	500	-	18,5
75	4	Q3EP280M4C	Cast Iron	489	1025	1xM50	368-419	457	280	647	24	75	140	79,5	20	6316	6316	80*100*10	80*100*10	550	450	500	-	18,5
90	2	Q3EP280M2D	Cast Iron	489	1025	1xM50	368-419	457	280	647	24	65	140	69,0	18	6316	6316	80*100*10	80*100*10	550	450	500	-	18,5
90	4	Q3EP280M4D	Cast Iron	489	1025	1xM50	368-419	457	280	647	24	75	140	79,5	20	6316	6316	80*100*10	80*100*10	550	450	500	-	18,5
110	2	Q3EP315S2C	Cast Iron	652	1176	2*M63	406	508	315	833	28	65	140	69	18	6316	6316	80*100*5,5	80*100*5,5	660	550	600	0	24
110	4	Q3EP315S4C	Cast Iron	652	1206	2*M63	406	508	315	833	28	80	170	85	22	6319	6319	95*115*5,5	95*115*5,5	660	550	600	0	24
132	2	Q3EP315M2B	Cast Iron	652	1176	2*M63	457	508	315	833	28	65	140	69	18	6316	6316	80*100*5,5	80*100*5,5	660	550	600	0	24
132	4	Q3EP315M4B	Cast Iron	652	1206	2*M63	457	508	315	833	28	80	170	85	22	6319	6319	95*115*5,5	95*115*5,5	660	550	600	0	24
160	2	Q3EP315L2A	Cast Iron	652	1287	2*M63	508	508	315	833	28	65	140	69	18	6316	6316	80*100*5,5	80*100*5,5	660	550	600	0	24
160	4	Q3EP315L4A	Cast Iron	652	1317	2*M63	508	508	315	833	28	80	170	85	22	6319	6319	95*115*5,5	95*115*5,5	660	550	600	0	24
200	2	Q3EP315L2C	Cast Iron	652	1287	2*M63	508	508	315	833	28	65	140	69	18	6316	6316	80*100*5,5	80*100*5,5	660	550	600	0	24
200	4	Q3EP315L4C	Cast Iron	652	1317	2*M63	508	508	315	833	28	80	170	85	22	6319	6319	95*115*5,5	95*115*5,5	660	550	600	0	24
250	2	Q3EP355M2C	Cast Iron	762	1512	4*M63	560	610	355	997	28	75	140	80	20	6317	6317	85*105*5,5	85*105*5,5	800	680	740	0	24
250	4	Q3EP355M4C	Cast Iron	762	1542	4*M63	560	610	355	997	28	95	170	100	25	6322	6322	110*130*5,5	110*130*5,5	800	680	740	0	24
315	2	Q3EP355L2B	Cast Iron	762	1512	4*M63	630	610	355	997	28	75	140	80	20	6317	6317	85*105*5,5	85*105*5,5	800	680	740	0	24
315	4	Q3EP355L4B	Cast Iron	762	1542	4*M63	630	610	355	997	28	95	170	100	25	6322	6322	110*130*5,5	110*130*5,5	800	680	740	0	24
355	2	Q3EP355L2C	Cast Iron	762	1512	4*M63	630	610	355	997	28	75	140	80	20	6317	6317	85*105*5,5	85*105*5,5	800	680	740	0	24
355	4	Q3EP355L4C	Cast Iron	762	1542	4*M63	630	610	355	997	28	95	170	100	25	6322	6322	110*130*5,5	110*130*5,5	800	680	740	0	24

(1) Tolerance DIN EN 50347 "j6" up to 28mm, "k6" above 28mm

(2) According to DIN 6885

(3) Tolerance DIN EN 50347 "j6"

DIMENSION - B14a, B34a

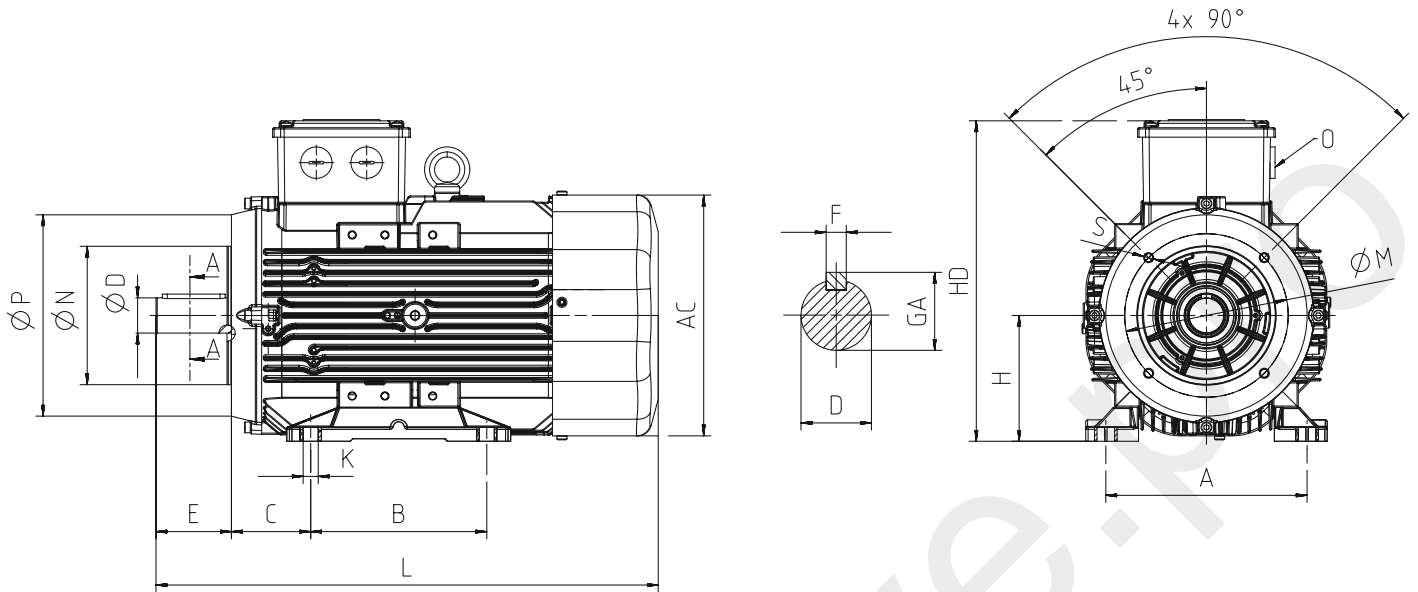

Power (kW)	Number of Poles	Motor Type	Housing Type	Main Dimensions			Foot Mounted Motors					Shaft			Bearing		Seal		Flange (FC) (B14a)					
				AC	L	O	B	A	H	HD	K	D ⁽¹⁾	E	GA	F ⁽²⁾	Drive Side	Non drive Side	Drive Side	Non drive Side	P	N ⁽³⁾	M	R	S
0,75	2	Q3H80M2C	Aluminium	158	268	1xM20	100	125	80	216	10	19	40	21,5	6	6204-ZZ	6204-ZZ	20*30*7	20*30*7	120	80	100	-	M6
0,75	4	Q3H80M4D	Aluminium	158	268	1xM20	100	125	80	216	10	19	40	21,5	6	6204-ZZ	6204-ZZ	20*30*7	20*30*7	120	80	100	-	M6
0,75	6	Q3H90L6C	Aluminium	172	344	1xM25	100-125	140	90	223	10	24	50	27,0	8	6305-ZZ	6205-ZZ	25*40*7	25*40*7	140	95	115	-	M8
1,1	2	Q3H80M2D	Aluminium	158	268	1xM20	100	125	80	216	10	19	40	21,5	6	6204-ZZ	6204-ZZ	20*30*7	20*30*7	120	80	100	-	M6
1,1	4	Q3H90L4C	Aluminium	158	303	1xM25	100-125	140	90	213	10	24	50	27,0	8	6305-ZZ	6204-ZZ	25*40*7	20*30*7	140	95	115	-	M8
1,1	6	Q3H90L6D	Aluminium	172	344	1xM25	100-125	140	90	223	10	24	50	27,0	8	6305-ZZ	6205-ZZ	25*40*7	25*40*7	140	95	115	-	M8
1,5	2	Q3H90L2C	Aluminium	158	303	1xM25	100-125	140	90	213	10	24	50	27,0	8	6305-ZZ	6204-ZZ	25*40*7	20*30*7	140	95	115	-	M8
1,5	4	Q3H90L4D	Aluminium	172	344	1xM25	100-125	140	90	223	10	24	50	27,0	8	6305-ZZ	6205-ZZ	25*40*7	25*40*7	140	95	115	-	M8
1,5	6	Q3H100L6D	Aluminium	191	400	1xM25	140	160	100	243	12	28	60	31,0	8	6306-ZZ	6205-ZZ	30*47*7	30*47*7	160	110	130	-	M8
2,2	2	Q3H90L2D	Aluminium	172	344	1xM25	100-125	140	90	223	10	24	50	27,0	8	6305-ZZ	6205-ZZ	25*40*7	25*40*7	140	95	115	-	M8
2,2	4	Q3H100L4C	Aluminium	172	384	1xM25	140	160	100	233	12	28	60	31,0	8	6306-ZZ	6205-ZZ	30*47*7	25*40*7	160	110	130	-	M8
2,2	6	Q3H112M6D	Aluminium	210	396	1xM25	140	190	112	265	12	28	60	31,0	8	6306-ZZ	6206-ZZ	30*47*7	30*47*7	160	110	130	-	M8
3	2	Q3H100L2D	Aluminium	172	349	1xM25	140	160	100	233	12	28	60	31,0	8	6306-ZZ	6205-ZZ	30*47*7	25*40*7	160	110	130	-	M8
3	4	Q3H100L4D	Aluminium	191	400	1xM25	140	160	100	243	12	28	60	31,0	8	6306-ZZ	6205-ZZ	30*47*7	30*47*7	160	110	130	-	M8
3	6	Q3H132S6A	Aluminium	260	481	1xM32	140-178	216	132	312	12	38	80	41,0	10	6208-ZZ	6208-ZZ	40*62*10	40*62*10	200	130	165	-	M10
4	2	Q3H112M2C	Aluminium	191	399	1xM25	140	190	112	254	12	28	60	31,0	8	6306-ZZ	6205-ZZ	30*47*7	25*40*7	160	110	130	-	M8
4	4	Q3H112M4D	Aluminium	210	396	1xM25	140	190	112	265	12	28	60	31,0	8	6306-ZZ	6206-ZZ	30*47*7	30*47*7	160	110	130	-	M8
4	6	Q3H132M6A	Aluminium	260	481	1xM32	140-178	216	132	312	12	38	80	41,0	10	6208-ZZ	6208-ZZ	40*62*10	40*62*10	200	130	165	-	M10
5,5	2	Q3H132S2C	Aluminium	210	422	1xM25	140-178	216	132	283	12	38	80	41,0	10	6208-ZZ	6206-ZZ	40*62*10	30*47*7	200	130	165	-	M10
5,5	4	Q3H132S4B	Aluminium	260	481	1xM32	140-178	216	132	312	12	38	80	41,0	10	6208-ZZ	6208-ZZ	40*62*10	40*62*10	200	130	165	-	M10
5,5	6	Q3H132M6B	Aluminium	260	481	1xM32	140-178	216	132	312	12	38	80	41,0	10	6208-ZZ	6208-ZZ	40*62*10	40*62*10	200	130	165	-	M10
7,5	2	Q3H132S2D	Aluminium	210	448	1xM25	140-178	216	132	283	12	38	80	41,0	10	6208-ZZ	6206-ZZ	40*62*10	30*47*7	200	130	165	-	M10
7,5	4	Q3H132M4D	Aluminium	260	481	1xM32	140-178	216	132	312	12	38	80	41,0	10	6208-ZZ	6208-ZZ	40*62*10	40*62*10	200	130	165	-	M10

(1) Tolerance DIN EN 50347 "j6" up to 28mm, "k6" above 28mm

(2) According to DIN 6885

(3) Tolerance DIN EN 50347 "j6"

DIMENSION - B14b, B34b

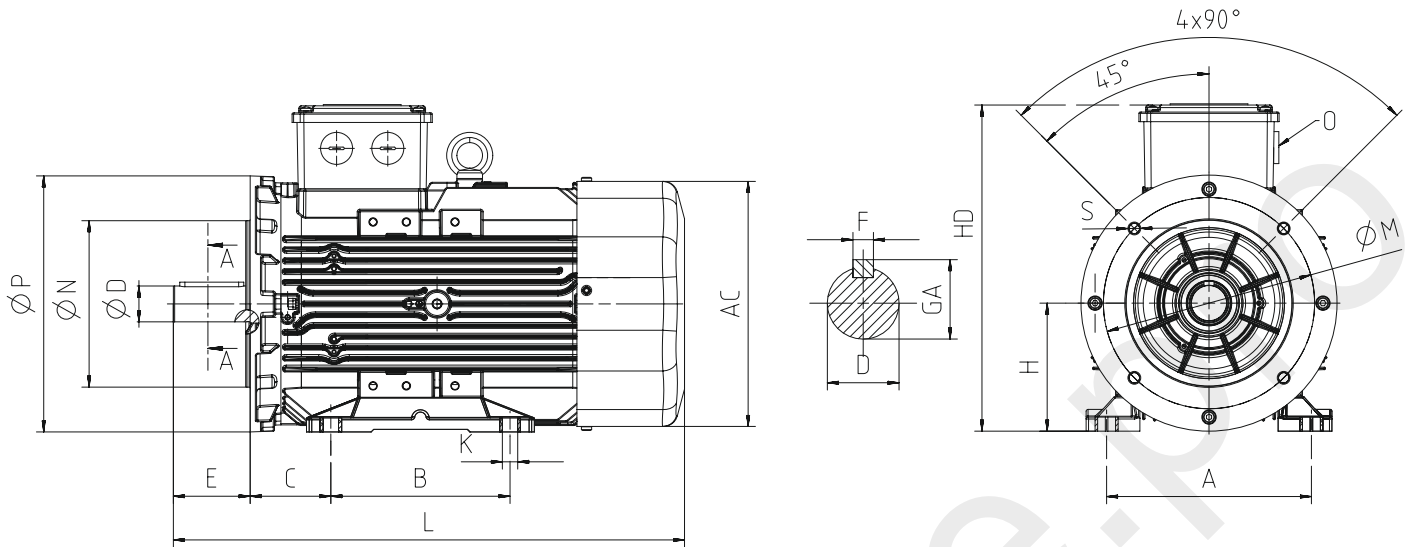

Power (kW)	Number of Poles	Motor Type	Housing Type	Main Dimensions			Foot Mounted Motors					Shaft			Bearing		Seal		Flange (FB) (B14b)					
				AC	L	O	B	A	H	HD	K	D ⁽¹⁾	E	GA	F ⁽²⁾	Drive Side	Non drive Side	Drive Side	Non drive Side	P	N ⁽³⁾	M	R	S
0,75	2	Q3H80M2C	Aluminium	158	268	1xM20	100	125	80	216	10	19	40	21,5	6	6204-ZZ	6204-ZZ	20*30*7	20*30*7	160	110	130	-	M8
0,75	4	Q3H80M4D	Aluminium	158	268	1xM20	100	125	80	216	10	19	40	21,5	6	6204-ZZ	6204-ZZ	20*30*7	20*30*7	160	110	130	-	M8
0,75	6	Q3H90L6C	Aluminium	172	344	1xM25	100-125	140	90	223	10	24	50	27,0	8	6305-ZZ	6205-ZZ	25*40*7	25*40*7	160	110	130	-	M8
1,1	2	Q3H80M2D	Aluminium	158	268	1xM20	100	125	80	216	10	19	40	21,5	6	6204-ZZ	6204-ZZ	20*30*7	20*30*7	160	110	130	-	M8
1,1	4	Q3H90L4C	Aluminium	158	303	1xM25	100-125	140	90	213	10	24	50	27,0	8	6305-ZZ	6204-ZZ	25*40*7	20*30*7	160	110	130	-	M8
1,1	6	Q3H90L6D	Aluminium	172	344	1xM25	100-125	140	90	223	10	24	50	27,0	8	6305-ZZ	6205-ZZ	25*40*7	25*40*7	160	110	130	-	M8
1,5	2	Q3H90L2C	Aluminium	158	303	1xM25	100-125	140	90	213	10	24	50	27,0	8	6305-ZZ	6204-ZZ	25*40*7	20*30*7	160	110	130	-	M8
1,5	4	Q3H90L4D	Aluminium	172	344	1xM25	100-125	140	90	223	10	24	50	27,0	8	6305-ZZ	6205-ZZ	25*40*7	25*40*7	160	110	130	-	M8
1,5	6	Q3H100L6D	Aluminium	191	400	1xM25	140	160	100	243	12	28	60	31,0	8	6306-ZZ	6205-ZZ	30*47*7	30*47*7	200	130	130	-	M10
2,2	2	Q3H90L2D	Aluminium	172	344	1xM25	100-125	140	90	223	10	24	50	27,0	8	6305-ZZ	6205-ZZ	25*40*7	25*40*7	260	110	130	-	M8
2,2	4	Q3H100L4C	Aluminium	172	384	1xM25	140	160	100	233	12	28	60	31,0	8	6306-ZZ	6205-ZZ	30*47*7	25*40*7	200	130	165	-	M10
2,2	6	Q3H112M6D	Aluminium	210	396	1xM25	140	190	112	265	12	28	60	31,0	8	6306-ZZ	6206-ZZ	30*47*7	30*47*7	200	130	165	-	M10
3	2	Q3H100L2D	Aluminium	172	349	1xM25	140	160	100	233	12	28	60	31,0	8	6306-ZZ	6205-ZZ	30*47*7	25*40*7	200	130	165	-	M10
3	4	Q3H100L4D	Aluminium	191	400	1xM25	140	160	100	243	12	28	60	31,0	8	6306-ZZ	6205-ZZ	30*47*7	30*47*7	200	130	165	-	M10
3	6	Q3H132S6A	Aluminium	260	481	1xM32	140-178	216	132	312	12	38	80	41,0	10	6208-ZZ	6208-ZZ	40*62*10	40*62*10	250	180	215	-	M12
4	2	Q3H112M2C	Aluminium	191	399	1xM25	140	190	112	254	12	28	60	31,0	8	6306-ZZ	6205-ZZ	30*47*7	25*40*7	200	130	165	-	M10
4	4	Q3H112M4D	Aluminium	210	396	1xM25	140	190	112	265	12	28	60	31,0	8	6306-ZZ	6206-ZZ	30*47*7	30*47*7	200	130	165	-	M10
4	6	Q3H132M6A	Aluminium	260	481	1xM32	140-178	216	132	312	12	38	80	41,0	10	6208-ZZ	6208-ZZ	40*62*10	40*62*10	250	180	215	-	M12
5,5	2	Q3H132S2C	Aluminium	210	422	1xM25	140-178	216	132	283	12	38	80	41,0	10	6208-ZZ	6206-ZZ	40*62*10	30*47*7	250	180	215	-	M12
5,5	4	Q3H132S4B	Aluminium	260	481	1xM32	140-178	216	132	312	12	38	80	41,0	10	6208-ZZ	6208-ZZ	40*62*10	40*62*10	250	180	215	-	M12
5,5	6	Q3H132M6B	Aluminium	260	481	1xM32	140-178	216	132	312	12	38	80	41,0	10	6208-ZZ	6208-ZZ	40*62*10	40*62*10	250	180	215	-	M12
7,5	2	Q3H132S2D	Aluminium	210	448	1xM25	140-178	216	132	283	12	38	80	41,0	10	6208-ZZ	6206-ZZ	40*62*10	30*47*7	250	180	215	-	M12
7,5	4	Q3H132M4D	Aluminium	260	481	1xM32	140-178	216	132	312	12	38	80	41,0	10	6208-ZZ	6208-ZZ	40*62*10	40*62*10	250	180	215	-	M12

(1) Tolerance DIN EN 50347 "j6" up to 28mm, "k6" above 28mm

(2) According to DIN 6885

(3) Tolerance DIN EN 50347 "j6"

ELECTRICAL CHARACTERISTICS AT 50 Hz

MOTOR TYPE	HOUSING TYPE	RATED VALUES					STARTING VALUES					Breakdown Torque Ratio Mk/ Mn	EFFICIENCY*			Cos φ	J kgm ²	Weight (B3) kg	Sound Pressure Level dBA**
		POWER		SPEED	CURRENT	TORQUE	CURRENT		TORQUE				η%						
		kW	HP	rpm	A	Nm	I_A / I_N λ	I_N Δ	M_A / M_N λ	M_N Δ	M_N Δ		4/4	3/4	2/4				
2 pole 3000 rpm																			
230/400V	Q3H80M2DE	Aluminium	1,5	2,0	2905	3,2	4,9	10,9	-	5	-	5,4	84,2	83,3	80,5	0,80	0,00224	15	59
	Q3H90L2E	Aluminium	3,0	4,0	2890	5,8	9,9	8,1	-	3	-	3,5	87,1	88,1	87,7	0,86	0,00318	19	63
400/690V	Q3H100L2DE	Aluminium	4,0	5,5	2936	8,0	13,0	3,6	10,9	1,6	4,8	5,7	88,1	88,1	85,8	0,82	0,00611	29	66
	Q3H112M2D	Aluminium	5,5	7,5	2920	10,5	18,1	3,5	10,5	1,2	3,7	5,1	89,2	89,0	87,2	0,86	0,00741	32	68
	Q3H112M2DE	Aluminium	7,5	10,0	2918	13,6	24,5	3,6	10,7	1,4	4,3	5,4	90,1	90,3	89,1	0,88	0,00921	42	69
	Q3H132M2A	Aluminium	11,0	15,0	2925	20,7	36,0	3,5	10,5	1,3	3,9	5,2	91,2	91,4	90,6	0,85	0,03489	61	69
	Q3H132M2B	Aluminium	15,0	20,0	2935	27,6	48,8	3,5	10,4	1,2	3,7	5,2	91,9	91,3	89,8	0,86	0,00402	77	71
	Q3H160L2D	Aluminium	22,0	30,0	2961	39,1	71,0	3,5	10,6	1,2	3,6	5,1	92,7	92,4	91,3	0,87	0,05539	114	70
	Q3H180M2B	Aluminium	30,0	40,0	2957	50,1	96,9	3,2	9,6	1,0	2,9	3,9	93,3	93,2	92,6	0,93	0,10277	148	77
Q3H200L2DE	Aluminium	45,0	60,0	2964	75,2	145,0	3,6	10,7	1,0	3,0	2,7	94,0	93,3	92,8	0,92	0,14769	199	78	
4 pole 1500 rpm																			
230/400V	Q3H80M4DE	Aluminium	1,1	1,5	1448	2,6	7,3	7,2	-	3,1	-	3,7	82,7	82,4	89,5	0,75	0,00306	14	48
	Q3H90L4DE	Aluminium	2,2	3,0	1453	5,4	14,4	9,5	-	5,0	-	5,5	86,7	84,3	80,6	0,68	0,00690	25	54
400/690V	Q3H100L4E	Aluminium	4,0	5,5	1445	8,8	26,4	8,6	-	3,5	-	4,2	88,6	87,1	85,6	0,75	0,01124	35	56
	Q3H112M4E	Aluminium	5,5	7,5	1443	11,25	36,4	2,8	8,3	1,0	3,1	3,8	89,6	89,2	88,3	0,80	0,01526	40	57
	Q3H132M4E	Aluminium	11,0	15,0	1470	19,2	71,3	2,7	8,0	0,7	2,1	3,8	91,4	91,5	90,4	0,90	0,05940	82	63
	Q3H160L4C	Aluminium	18,5	25,0	1474	39,5	119,9	2,5	7,4	0,8	2,3	3,5	92,6	91,9	91,2	0,74	0,10511	114	58
	Q3H180L4C	Aluminium	30,0	40,0	1475	54,8	194,2	2,5	7,6	0,8	2,3	2,8	93,6	93,2	92,3	0,85	0,22165	187	69

* According to IEC 60034-2-1

** The sound pressure measurements are taken 1m away from the motor

*** Tolerance +3 dBA

DIMENSION - B3

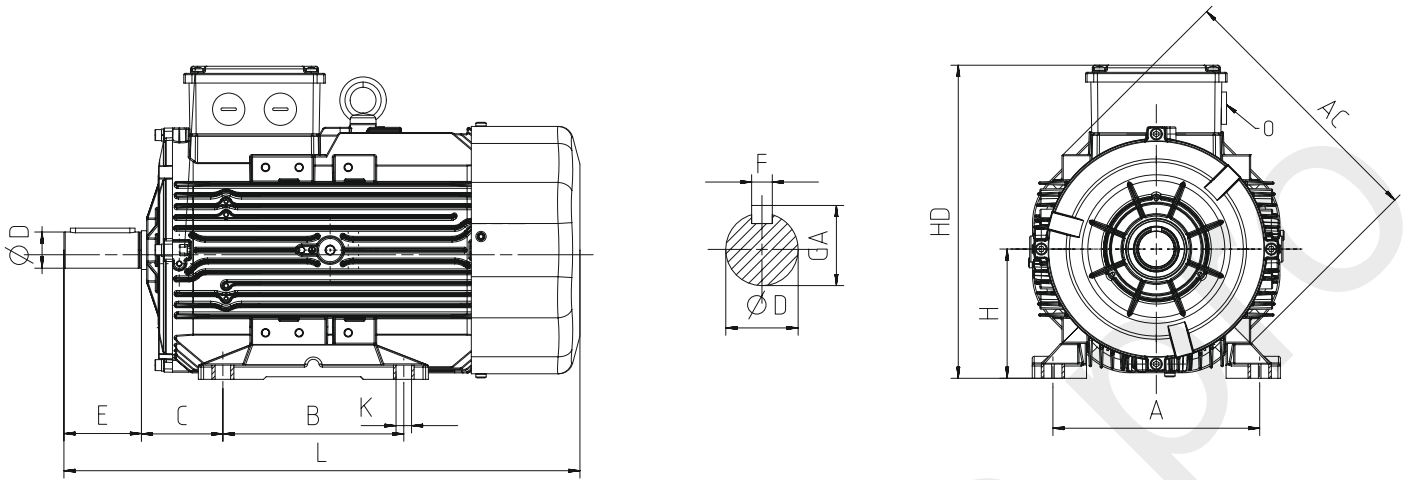

Power (kW)	Number of Poles	Motor Type	Housing Type	Main Dimensions			Foot Mounted Motors					Shaft				Bearing		Seal		
				AC	L	O	B	A	H	HD	K	C	D ⁽¹⁾	E	GA	F ⁽²⁾	Drive Side	Non drive Side	Drive Side	Non drive Side
1,1	4	Q3H80M4DE	Aluminium	158	268	1xM20	100	125	80	216	10	50	19	40	21,5	6	6204-ZZ	6204-ZZ	20*30*7	20*30*7
1,5	2	Q3H80M2DE	Aluminium	158	268	1xM20	100	125	80	216	10	50	19	40	21,5	6	6204-ZZ	6204-ZZ	20*30*7	20*30*7
2,2	4	Q3H90L4DE	Aluminium	172	344	1xM25	100-125	140	90	223	10	56	24	50	27,0	8	6305-ZZ	6205-ZZ	25*40*7	25*40*7
3,0	2	Q3H90L2E	Aluminium	172	344	1xM25	100-125	140	90	223	10	56	24	50	27,0	8	6305-ZZ	6205-ZZ	25*40*7	25*40*7
4,0	2	Q3H100L2DE	Aluminium	191	400	1xM25	140	160	100	243	12	63	28	60	31,0	8	6306-ZZ	6205-ZZ	30*47*7	30*47*7
4,0	4	Q3H100L4E	Aluminium	191	422	1xM25	140	160	100	243	12	63	28	60	31,0	8	6306-ZZ	6205-ZZ	30*47*7	30*47*7
5,5	2	Q3H112M2D	Aluminium	210	396	1xM25	140	190	112	265	12	70	28	60	31,0	8	6306-ZZ	6206-ZZ	30*47*7	30*47*7
5,5	4	Q3H112M4E	Aluminium	210	421	1xM25	140	190	112	265	12	70	28	60	31,0	8	6306-ZZ	6206-ZZ	30*47*7	30*47*7
7,5	2	Q3H112M2DE	Aluminium	210	421	1xM25	140	190	112	265	12	70	28	60	31,0	8	6306-ZZ	6206-ZZ	30*47*7	30*47*7
11,0	2	Q3H132M2A	Aluminium	260	481	1xM32	140-178	216	132	312	12	89	38	80	41,0	10	6208-ZZ	6208-ZZ	40*62*10	40*62*10
11,0	4	Q3H132M4E	Aluminium	260	520	1xM32	140-178	216	132	312	12	89	38	80	41,0	10	6309-ZZ	6209-ZZ	40*62*10	40*62*10
15,0	2	Q3H132M2B	Aluminium	260	520	1xM32	140-178	216	132	312	12	89	38	80	41,0	10	6208-ZZ	6208-ZZ	40*62*10	40*62*10
18,5	4	Q3H160L4C	Aluminium	305	591	1xM32	210-254	254	160	368	14,5	108	42	110	45,0	12	6309-ZZ	6209-ZZ	45*72*10	45*72*10
30,0	4	Q3H180L4C	Aluminium	349	696	1xM40	241-279	279	180	437	14,5	121	48	110	51,5	14	6310-ZZ	6310-ZZ	50*80*10	50*80*10
22,0	2	Q3H160L2D	Aluminium	305	591	1xM32	210-254	254	160	368	14,5	108	42	110	45,0	12	6309-ZZ	6209-ZZ	45*72*10	45*72*10
30,0	2	Q3H180M2B	Aluminium	349	696	1xM40	241-279	279	180	437	14,5	121	48	110	51,5	14	6310-ZZ	6310-ZZ	50*80*10	50*80*10
45,0	2	Q3H200L2DE	Aluminium	349	759	1xM50	267-305	318	200	455	18,5	133	55	110	59,0	16	6312-ZZ	6310-ZZ	60*90*10	60*90*10

(1) Tolerance DIN EN 50347 "j6" up to 28mm, "k6" above 28mm

(2) According to DIN 6885

DIMENSION - B5, B35

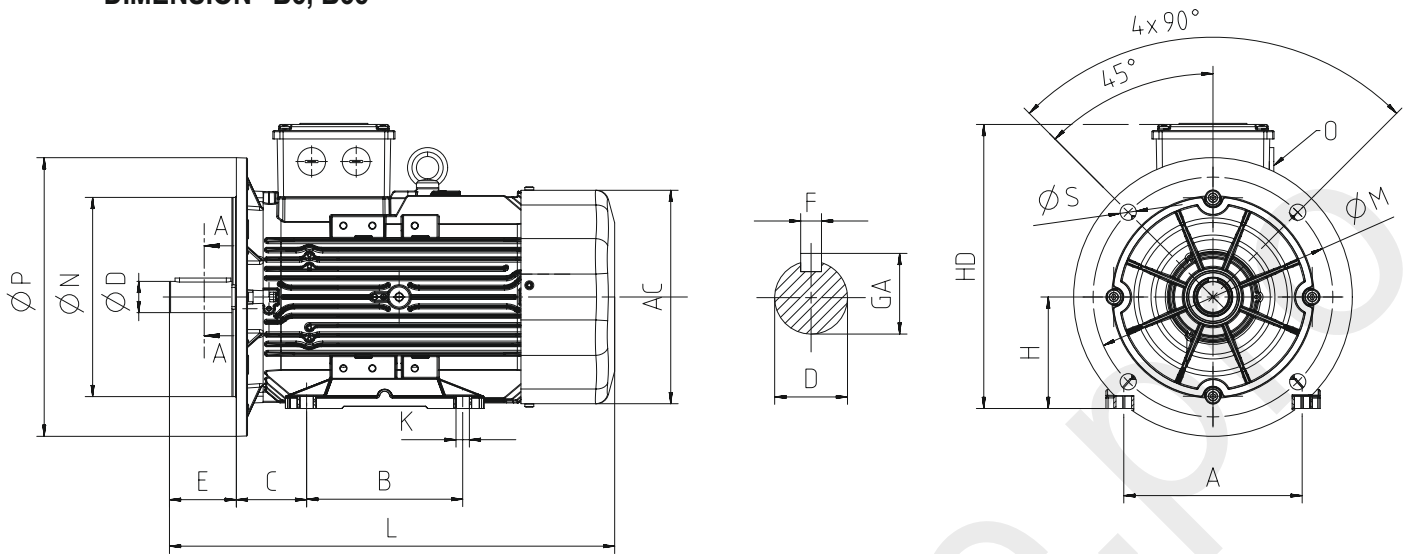

Power (kW)	Number of Poles	Motor Type	Housing Type	Main Dimensions			Foot Mounted Motors				Shaft				Bearing		Seal		Flange (FA) (B5)					
				AC	L	O	B	A	H	HD	K	D ⁽¹⁾	E	GA	F ⁽²⁾	Drive Side	Non drive Side	Drive Side	Non drive Side	P	N ⁽³⁾	M	R	S
1,1	4	Q3H80M4DE	Aluminium	158	268	1xM20	100	125	80	216	10	19	40	21,5	6	6204-ZZ	6204-ZZ	20*30*7	20*30*7	200	130	165	-	12
1,5	2	Q3H80M2DE	Aluminium	158	268	1xM20	100	125	80	216	10	19	40	21,5	6	6204-ZZ	6204-ZZ	20*30*7	20*30*7	200	130	165	-	12
2,2	4	Q3H90L4DE	Aluminium	172	344	1xM25	100-125	140	90	223	10	24	50	27,0	8	6305-ZZ	6205-ZZ	25*40*7	25*40*7	200	130	165	-	12
3	2	Q3H90L2E	Aluminium	172	344	1xM25	100-125	140	90	223	10	24	50	27,0	8	6305-ZZ	6205-ZZ	25*40*7	25*40*7	200	130	165	-	12
4	2	Q3H100L2DE	Aluminium	191	400	1xM25	140	160	100	243	12	28	60	31,0	8	6306-ZZ	6205-ZZ	30*47*7	30*47*7	250	180	215	-	14,5
4	4	Q3H100L4E	Aluminium	191	422	1xM25	140	160	100	243	12	28	60	31,0	8	6306-ZZ	6205-ZZ	30*47*7	30*47*7	250	180	215	-	14,5
5,5	2	Q3H112M2D	Aluminium	210	396	1xM25	140	190	112	265	12	28	60	31,0	8	6306-ZZ	6206-ZZ	30*47*7	30*47*7	250	180	215	-	14,5
5,5	4	Q3H112M4E	Aluminium	210	421	1xM25	140	190	112	265	12	28	60	31,0	8	6306-ZZ	6206-ZZ	30*47*7	30*47*7	250	180	215	-	14,5
7,5	2	Q3H112M2DE	Aluminium	210	421	1xM25	140	190	112	265	12	28	60	31,0	8	6306-ZZ	6206-ZZ	30*47*7	30*47*7	250	180	215	-	14,5
11	2	Q3H132M2A	Aluminium	260	481	1xM32	140-178	216	132	312	12	38	80	41,0	10	6208-ZZ	6208-ZZ	40*62*10	40*62*10	300	230	265	-	14,5
11	4	Q3H132M4E	Aluminium	260	520	1xM32	140-178	216	132	312	12	38	80	41,0	10	6309-ZZ	6209-ZZ	40*62*10	40*62*10	300	230	265	-	14,5
15	2	Q3H132M2B	Aluminium	260	520	1xM32	140-178	216	132	312	12	38	80	41,0	10	6208-ZZ	6208-ZZ	40*62*10	40*62*10	300	230	265	-	14,5
18,5	4	Q3H160L4C	Aluminium	305	591	1xM32	210-254	254	160	368	14,5	42	110	45,0	12	6309-ZZ	6209-ZZ	45*72*10	45*72*10	350	250	300	-	18,5
30	4	Q3H180L4C	Aluminium	349	696	1xM40	241-279	279	180	437	14,5	48	110	51,5	14	6310-ZZ	6310-ZZ	50*80*10	50*80*10	350	250	300	-	18,5
22	2	Q3H160L2D	Aluminium	305	591	1xM32	210-254	254	160	368	14,5	42	110	45,0	12	6309-ZZ	6209-ZZ	45*72*10	45*72*10	350	250	300	-	18,5
30	2	Q3H180M2B	Aluminium	349	696	1xM40	241-279	279	180	437	14,5	48	110	51,5	14	6310-ZZ	6310-ZZ	50*80*10	50*80*10	350	250	300	-	18,5
45	2	Q3H200L2DE	Aluminium	349	759	1xM50	267-305	318	200	455	18,5	55	110	59,0	16	6312-ZZ	6310-ZZ	60*90*10	60*90*10	400	300	350	-	18,5

(1) Tolerance DIN EN 50347 "j6" up to 28mm, "k6" above 28mm
(2) According to DIN 6885
(3) Tolerance DIN EN 50347 "j6"

DIMENSION - B14a, B34a

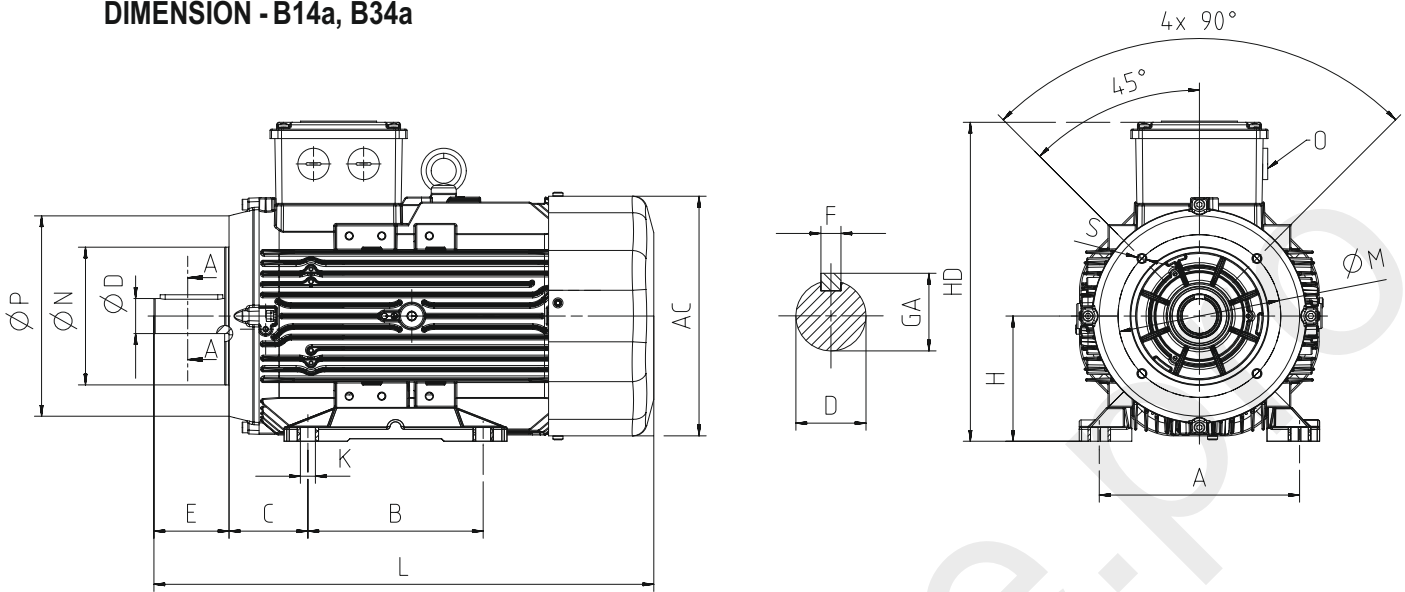

Power (kW)	Number of Poles	Motor Type	Housing Type	Main Dimensions			Foot Mounted Motors					Shaft				Bearing		Seal		Flange (FC) (B14a)				
				AC	L	O	B	A	H	HD	K	D ⁽¹⁾	E	GA	F ⁽²⁾	Drive Side	Non drive Side	Drive Side	Non drive Side	P	N ⁽³⁾	M	R	S
1,1	4	Q3H80M4DE	Aluminium	158	268	1xM20	100	125	80	216	10	19	40	21,5	6	6204-ZZ	6204-ZZ	20*30*7	20*30*7	120	80	100	-	M6
1,5	2	Q3H80M2DE	Aluminium	158	268	1xM20	100	125	80	216	10	19	40	21,5	6	6204-ZZ	6204-ZZ	20*30*7	20*30*7	120	80	100	-	M6
2,2	4	Q3H90L4DE	Aluminium	172	344	1xM25	100-125	140	90	223	10	24	50	27,0	8	6305-ZZ	6205-ZZ	25*40*7	25*40*7	140	95	115	-	M8
3	2	Q3H90L2E	Aluminium	172	344	1xM25	100-125	140	90	223	10	24	50	27,0	8	6305-ZZ	6205-ZZ	25*40*7	25*40*7	140	95	115	-	M8
4	2	Q3H100L2DE	Aluminium	191	400	1xM25	140	160	100	243	12	28	60	31,0	8	6306-ZZ	6205-ZZ	30*47*7	30*47*7	160	110	130	-	M8
4	4	Q3H100L4E	Aluminium	191	422	1xM25	140	160	100	243	12	28	60	31,0	8	6306-ZZ	6205-ZZ	30*47*7	30*47*7	160	110	130	-	M8
5,5	2	Q3H112M2D	Aluminium	210	396	1xM25	140	190	112	265	12	28	60	31,0	8	6306-ZZ	6206-ZZ	30*47*7	30*47*7	160	110	130	-	M8
5,5	4	Q3H112M4E	Aluminium	210	421	1xM25	140	190	112	265	12	28	60	31,0	8	6306-ZZ	6206-ZZ	30*47*7	30*47*7	160	110	130	-	M8
7,5	2	Q3H112M2DE	Aluminium	210	421	1xM25	140	190	112	265	12	28	60	31,0	8	6306-ZZ	6206-ZZ	30*47*7	30*47*7	160	110	130	-	M8
11	2	Q3H132M2A	Aluminium	260	481	1xM32	140-178	216	132	312	12	38	80	41,0	10	6208-ZZ	6208-ZZ	40*62*10	40*62*10	200	130	165	-	M10
11	4	Q3H132M4E	Aluminium	260	520	1xM32	140-178	216	132	312	12	38	80	41,0	10	6208-ZZ	6208-ZZ	40*62*10	40*62*10	200	130	165	-	M10
15	2	Q3H132M2B	Aluminium	260	520	1xM32	140-178	216	132	312	12	38	80	41,0	10	6208-ZZ	6208-ZZ	40*62*10	40*62*10	200	130	165	-	M10

(1) Tolerance DIN EN 50347 "j6" up to 28mm, "k6" above 28mm

(2) According to DIN 6885

(3) Tolerance DIN EN 50347 "j6"

DIMENSION - B14b, B34b

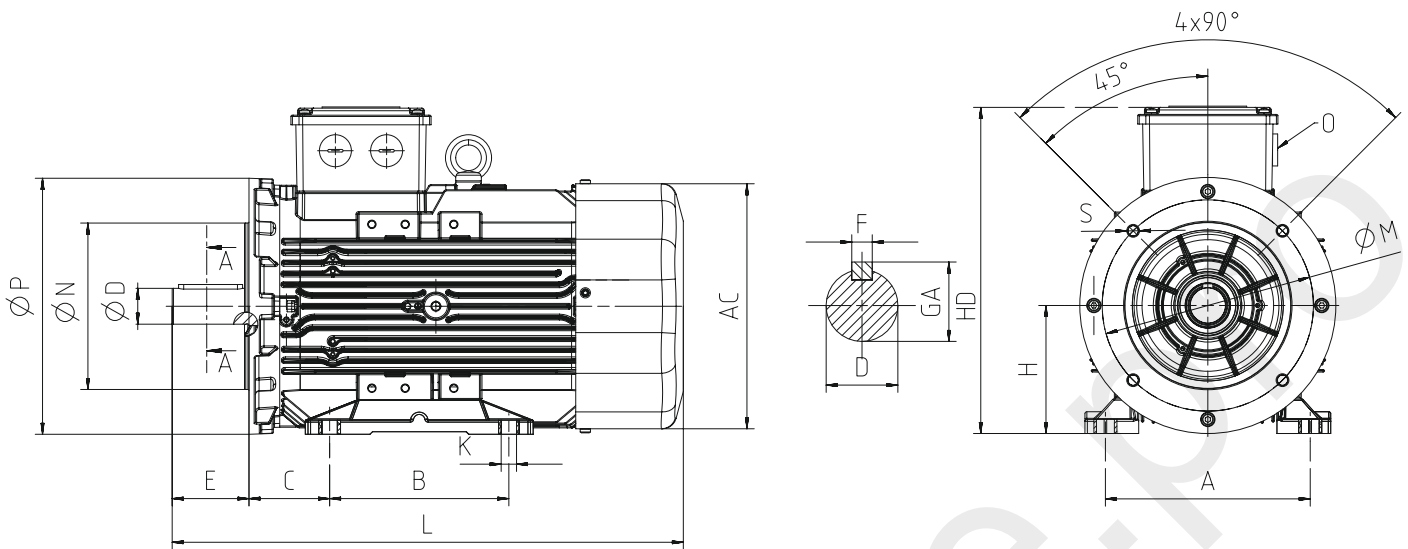

Power (kW)	Number of Poles	Motor Type	Housing Type	Main Dimensions			Foot Mounted Motors					Shaft				Bearing		Seal		Flange (FB) (B14b)				
				AC	L	O	B	A	H	HD	K	D ⁽¹⁾	E	GA	F ⁽²⁾	Drive Side	Non drive Side	Drive Side	Non drive Side	P	N ⁽³⁾	M	R	S
1,1	4	Q3H80M4DE	Aluminium	158	268	1xM20	100	125	80	216	10	19	40	21,5	6	6204-ZZ	6204-ZZ	20*30*7	20*30*7	160	110	130	-	M8
1,5	2	Q3H80M2DE	Aluminium	158	268	1xM20	100	125	80	216	10	19	40	21,5	6	6204-ZZ	6204-ZZ	20*30*7	20*30*7	160	110	130	-	M8
2,2	4	Q3H90L4DE	Aluminium	172	344	1xM25	100-125	140	90	223	10	24	50	27,0	8	6305-ZZ	6205-ZZ	25*40*7	25*40*7	160	110	130	-	M8
3	2	Q3H90L2E	Aluminium	172	344	1xM25	100-125	140	90	223	10	24	50	27,0	8	6305-ZZ	6205-ZZ	25*40*7	25*40*7	160	110	130	-	M8
4	2	Q3H100L2DE	Aluminium	191	400	1xM25	140	160	100	243	12	28	60	31,0	8	6306-ZZ	6205-ZZ	30*47*7	30*47*7	200	130	165	-	M10
4	4	Q3H100L4E	Aluminium	191	422	1xM25	140	160	100	243	12	28	60	31,0	8	6306-ZZ	6205-ZZ	30*47*7	30*47*7	200	130	165	-	M10
5,5	2	Q3H112M2D	Aluminium	210	396	1xM25	140	190	112	265	12	28	60	31,0	8	6306-ZZ	6206-ZZ	30*47*7	30*47*7	200	130	165	-	M10
5,5	4	Q3H112M4E	Aluminium	210	421	1xM25	140	190	112	265	12	28	60	31,0	8	6306-ZZ	6206-ZZ	30*47*7	30*47*7	200	130	165	-	M10
7,5	2	Q3H112M2DE	Aluminium	210	421	1xM25	140	190	112	265	12	28	60	31,0	8	6306-ZZ	6206-ZZ	30*47*7	30*47*7	200	130	165	-	M10
11	2	Q3H132M2A	Aluminium	260	481	1xM32	140-178	216	132	312	12	38	80	41,0	10	6208-ZZ	6208-ZZ	40*62*10	40*62*10	250	180	215	-	M12
11	4	Q3H132M4E	Aluminium	260	520	1xM32	140-178	216	132	312	12	38	80	41,0	10	6208-ZZ	6208-ZZ	40*62*10	40*62*10	250	180	215	-	M12
15	2	Q3H132M2B	Aluminium	260	520	1xM32	140-178	216	132	312	12	38	80	41,0	10	6208-ZZ	6208-ZZ	40*62*10	40*62*10	250	180	215	-	M12

(1) Tolerance DIN EN 50347 "j6" up to 28mm, "k6" above 28mm
(2) According to DIN 6885
(3) Tolerance DIN EN 50347 "j6"

IE2

technoadvance.pro

ELECTRICAL CHARACTERISTICS AT 50 Hz

MOTOR TYPE	HOUSING TYPE	RATED VALUES					STARTING VALUES					Breakdown Torque Ratio	EFFICIENCY*			Cos φ	J	Weight (B3)	Sound Pressure Level
		POWER		SPEED	CURRENT	TORQUE	CURRENT		TORQUE		Mk/ Mn		η%						
		kW	HP	rpm	A	Nm	I_A / I_N	$I_Δ / I_N$	M_A / M_N	$M_Δ / M_N$			4/4	3/4	2/4				
2 pole 3000 rpm																			
230/400V	Q2E63M2A	Aluminium	0,18	1/4	2810	0,4	0,6	4,7	-	2,1	-	2,3	59,1	63,8	58,5	0,85	0,00022	5	52
	Q2E63M2B	Aluminium	0,25	1/3	2820	0,6	0,8	5,6	-	2,7	-	2,7	64,7	66,2	63,5	0,84	0,00025	6	52
	Q2E71M2A	Aluminium	0,37	1/2	2850	0,8	1,2	8,1	-	4,0	-	4,2	69,5	69,6	67,3	0,80	0,00067	8	54
	Q2E71M2B	Aluminium	0,55	3/4	2880	1,2	1,8	8,2	-	4,1	-	4,3	74,1	74,3	74,2	0,82	0,00086	10	54
	Q2H80M2B	Aluminium	0,75	1,0	2850	1,7	2,5	6,4	-	2,8	-	3,3	77,4	77,6	74,4	0,82	0,00111	9	58
	Q2H80M2C	Aluminium	1,1	1,5	2860	2,5	3,7	6,7	-	2,8	-	3,3	79,6	79,8	77,0	0,81	0,00140	11	58
	Q2H90L2B	Aluminium	1,5	2,0	2875	3,8	5,0	8,0	-	3,9	-	4,4	81,3	80,4	76,6	0,74	0,00176	13	62
	Q2H90L2D	Aluminium	2,2	3,0	2870	4,7	7,3	9,1	-	3,9	-	4,4	83,2	82,8	81,3	0,83	0,00231	16	62
	Q2H100L2C	Aluminium	3,0	4,0	2887	6,3	9,9	7,3	-	2,4	-	2,9	84,6	85,4	84,2	0,83	0,00266	19	66
400/690V	Q2H112M2B	Aluminium	4,0	5,5	2900	8,0	13,2	3,1	9,3	1,1	3,2	4,0	85,8	86,1	84,5	0,85	0,00487	24	68
	Q2H132S2B	Aluminium	5,5	7,5	2915	10,6	18,0	3,5	10,6	1,5	4,4	5,3	87,0	87,1	84,9	0,86	0,00703	34	69
	Q2H132S2C	Aluminium	7,5	10,0	2900	14,6	24,7	3,5	10,6	1,3	3,8	4,6	88,1	88,6	87,6	0,85	0,00772	37	69
	Q2H160M2B	Aluminium	11,0	15,0	2923	21,2	35,9	3,1	9,2	1,1	3,3	4,8	89,4	89,9	88,4	0,83	0,03517	65	70
	Q2H160M2C	Aluminium	15,0	20,0	2915	30,0	49,2	3,2	9,6	1,3	3,9	5,1	90,3	90,6	89,6	0,80	0,04015	67	70
	Q2H160M2D	Aluminium	18,5	25,0	2930	30,8	60,3	2,7	8,0	0,6	1,9	3,6	90,9	91,7	91,1	0,95	0,04613	79	70
	Q2H180M2A	Aluminium	22,0	30,0	2955	40,9	71,2	3,5	10,6	1,2	3,6	5,2	91,3	92,0	90,7	0,84	0,05141	100	77
	Q2H200L2B	Aluminium	30,0	40,0	2955	51,5	97,1	2,8	8,5	0,8	2,4	3,6	92,0	92,5	91,8	0,91	0,08644	175	78
	Q2H200L2C	Aluminium	37,0	50,0	2965	66,2	119,6	3,4	10,1	1,0	3,1	4,5	92,5	92,5	91,2	0,87	0,10277	175	78
	Q2E225M2B	Aluminium	45,0	60,0	2960	82,1	145,2	2,9	8,7	0,8	2,4	2,9	92,9	92,6	91,1	0,85	0,23500	235	81
	Q2E250M2A	Cast Iron	55,0	75,0	2976	92,7	177,0	2,8	8,4	0,8	2,5	3,4	93,2	93,0	91,6	0,91	0,48700	486	82
	Q2EP280M2B	Cast Iron	75,0	100,0	2975	127,9	240,8	3,5	10,6	0,9	2,7	5,1	93,8	93,7	92,5	0,92	0,54000	576	84
	Q2EP280M2C	Cast Iron	90,0	125,0	2980	149,0	288,6	2,4	7,1	1,0	3,0	3,0	94,1	93,9	92,9	0,91	0,64500	585	84
	Q2EP315S2C	Cast Iron	110,0	127	2,975	185	353	2,6	7,8	0,7	2,2	2,4	94,3	94,3	93,1	0,91	1,43600	920	87
	Q2EP315M2C	Cast Iron	132,0	152	2,975	221	423	2,6	7,8	0,8	2,3	2,4	94,6	94,6	93,4	0,91	1,72300	970	87
	Q2EP315L2C	Cast Iron	160,0	184	2,975	268	513	2,5	7,5	0,8	2,3	2,4	94,8	94,8	93,6	0,91	1,95300	1170	87
	Q2EP315L2D	Cast Iron	200,0	230	2,975	334	643	2,7	8	0,8	2,4	2,6	95	95	93,8	0,91	2,52700	1200	87
	Q2EP355M2C	Cast Iron	250,0	280	2,985	422	799	2,3	7	0,7	2	2,4	95	95	93,8	0,90	3,92000	1690	87
	Q2EP355L2C	Cast Iron	315,0	353,0	2,985	532	1.007	2,5	7,4	0,7	2,0	2,3	95,0	95,0	93,8	0,90	4,17000	1.870	87
	Q2EP355L2D	Cast Iron	355,0	398,0	2985	599	1.135	2,5	7,5	0,6	1,8	2,1	95,0	95,0	93,8	0,90	4,44000	1953	87

* According to IEC 60034-2-1

** The sound pressure measurements are taken 1m away from the motor

*** Tolerance +3 dBA

MOTOR TYPE	HOUSING TYPE	RATED VALUES					STARTING VALUES					Breakdown Torque Ratio Mk/ Mn	EFFICIENCY* η%			Cos φ	J kgm ²	Weight (B3) kg	Sound Pressure Level dBA**
		POWER		SPEED	CURRENT	TORQUE	CURRENT I_A / I_N		TORQUE M_A / M_N		4/4		3/4	2/4					
		kW	HP	rpm	A	Nm	λ	Δ	λ	Δ									
4 pole 1500 rpm																			
230/400V	Q2E63M4A	Aluminium	0,12	1/6	1420	0,5	0,9	3,4	-	2,2	-	3,2	64,0	54,1	44,9	0,56	0,00022	5	41
	Q2E63M4B	Aluminium	0,18	1/4	1400	0,6	1,2	3,7	-	2,7	-	3,0	68,0	60,0	51,3	0,66	0,00026	6	41
	Q2E71M4A	Aluminium	0,25	1/3	1415	0,6	1,7	4,6	-	2,6	-	3,8	68,5	68,8	66,9	0,70	0,00095	9	45
	Q2E71M4B	Aluminium	0,37	1/2	1425	1,1	2,5	4,6	-	2,6	-	3,8	72,7	73,1	72,0	0,71	0,00095	9	45
	Q2H80M4B	Aluminium	0,55	3/4	1435	1,3	3,6	6,4	-	2,3	-	3,2	77,1	78,8	75,4	0,76	0,00175	10	49
	Q2H80M4C	Aluminium	0,75	1,0	1440	1,8	5,0	5,5	-	2,1	-	2,6	79,6	80,0	77,7	0,76	0,00216	11	49
	Q2H90L4C	Aluminium	1,10	1,5	1430	2,5	7,4	5,7	-	2,2	-	2,6	81,4	82,4	81,6	0,80	0,00267	13	54
	Q2H90L4C	Aluminium	1,50	2,0	1427	3,3	10,0	6,4	-	2,5	-	3,1	82,8	84,2	83,7	0,79	0,00328	15	54
	Q2H100L4B	Aluminium	2,20	3,0	1437	5,3	14,6	7,6	-	3,6	-	4,2	84,3	84,1	81,5	0,72	0,00521	21	55
	Q2H100L4C	Aluminium	3,00	4,0	1440	7,4	20,0	6,5	-	3,3	-	3,7	85,5	85,3	83,0	0,70	0,00694	25	55
400/690V	Q2H112M4C	Aluminium	4,00	5,5	1440	8,7	26,6	2,7	8,0	1,1	3,2	3,8	86,6	85,7	83,5	0,78	0,01085	31	58
	Q2H132S4A	Aluminium	5,50	7,5	1445	11,5	35,5	2,7	8,0	1,0	3,0	3,8	87,7	88,3	87,3	0,79	0,01414	38	59
	Q2H132M4C	Aluminium	7,50	10,0	1460	15,0	49,1	2,4	7,1	0,5	1,5	0,6	88,7	89,4	88,7	0,82	0,03560	54	62
	Q2H160M4C	Aluminium	11,00	15,0	1468	21,6	71,5	2,6	7,9	0,7	2,1	3,6	89,8	91,1	90,3	0,81	0,05468	79	63
	Q2H160L4B	Aluminium	15,00	20,0	1462	29,8	98,0	2,6	7,8	0,6	1,8	3,4	90,6	91,4	90,9	0,80	0,05940	83	63
	Q2H180M4A	Aluminium	18,50	25,0	1470	36,0	120,2	2,3	6,8	0,7	2,2	2,9	91,2	92,0	91,6	0,81	0,10513	110	67
	Q2H180M4B	Aluminium	22,00	30,0	1462	41,8	143,8	1,8	5,5	0,6	1,9	2,8	91,6	92,9	93,3	0,84	0,11398	118	67
	Q2H200L4C	Aluminium	30,00	40,0	1475	55,3	194,6	2,7	8,2	0,9	2,7	3,5	92,0	91,9	91,4	0,85	0,18660	195	70
	Q2E225M4A	Aluminium	37,00	50,0	1480	68,3	238,8	3,0	9,1	1,2	3,6	4,0	92,7	92,6	91,3	0,84	0,36420	263	71
	Q2E225M4B	Aluminium	45,00	60,0	1480	81,5	290,5	3,1	9,4	1,2	3,7	3,0	93,1	93,0	91,9	0,85	0,43500	280	71
	Q2E250M4A	Cast Iron	55,00	75,0	1486	104,8	353,5	2,4	7,2	0,8	2,3	3,0	93,5	93,7	93,3	0,81	0,36400	506	72
	Q2EP280M4B	Cast Iron	75,00	100,0	1485	134,2	485,7	2,6	7,8	1,0	2,9	3,4	94,0	93,9	93,2	0,86	1,06100	624	73
	Q2EP280M4C	Cast Iron	90,00	125,0	1486	163,5	584,2	2,6	7,8	1,0	2,9	3,3	94,2	94,6	94,2	0,85	1,14800	638	73
	Q2EP315S4C	Cast Iron	110,0	127,0	1480	191	709	2,4	7,2	0,7	2,2	2,5	94,5	94,5	93,9	0,88	3,03500	925	70
	Q2EP315M4C	Cast Iron	132,0	152,0	1480	229	851	2,3	7,0	0,7	2,1	2,4	94,7	94,7	94,1	0,88	3,41500	1.010	70
	Q2EP315L4C	Cast Iron	160,0	184,0	1480	273	1.032	2,5	7,5	0,7	2,2	2,5	94,9	94,9	94,3	0,89	4,11900	1.080	76
	Q2EP315L4D	Cast Iron	200,0	230,0	1480	341	1.290	2,5	7,5	0,8	2,3	2,5	95,1	95,1	94,5	0,89	5,20300	1.200	76
	Q2EP355M4C	Cast Iron	250,0	280,0	1485	426	1.607	2,6	7,9	0,8	2,3	2,5	95,1	95,1	94,5	0,89	8,79000	1.720	76
Q2EP355L4C	Cast Iron	315,0	353,0	1485	531	2.025	2,5	7,4	0,7	2,0	2,3	95,1	95,1	94,5	0,90	10,13300	1.920	87	
Q2EP355L4D	Cast Iron	355,0	398,0	1485	603	2.283	2,9	8,8	0,6	1,8	2,0	95,1	95,1	94,5	0,89	10,67800	1.953	87	
6 pole 1000 rpm																			
230/400V	Q2H90S6B	Aluminium	0,75	1,0	943	1,8	7,7	4,6	-	2,1	-	2,7	75,9	75,1	71,4	0,69	0,00383	16	53
	Q2H90L6C	Aluminium	1,10	1,5	938	3,0	11,2	2,8	-	2,4	-	2,8	78,1	78,0	75,1	0,69	0,00464	18	53
	Q2H100L6C	Aluminium	1,50	2,0	955	4,0	15,2	3,3	-	2,6	-	3,2	79,8	79,3	76,3	0,67	0,00871	26	56
	Q2H112M6C	Aluminium	2,20	3,0	942	5,4	22,4	5,2	-	2,0	-	2,6	81,8	81,5	79,5	0,72	0,00936	31	58
400/690V	Q2H132S6A	Aluminium	3,00	4,0	965	14,1	29,8	1,8	5,4	1,1	3,2	3,3	83,3	82,3	79,4	0,64	0,02950	47	62
	Q2H132M6A	Aluminium	4,00	5,5	970	10,4	39,8	1,9	5,8	0,7	2,2	2,6	84,6	83,5	80,7	0,65	0,03560	53	61
	Q2H132M6B	Aluminium	5,50	7,5	960	12,8	54,7	1,7	5,2	0,9	2,6	2,9	86,1	85,7	83,9	0,72	0,06420	67	60
	Q2H160M6B	Aluminium	7,50	10,0	970	18,9	74,6	2,1	6,2	1,2	3,6	3,8	87,2	84,3	81,7	0,66	0,07540	88	63
	Q2H160L6B	Aluminium	11,00	15,0	970	25,5	109,4	1,7	5,2	1,0	3,0	3,1	88,7	88,5	86,3	0,71	0,07040	99	63
	Q2H180L6A	Aluminium	15,00	20,0	970	31,5	146,9	1,8	5,1	0,6	1,8	2,0	89,7	89,5	87,30,0	0,76	0,16677	115	69
	Q2H200L6B	Aluminium	18,50	25,0	981	41,6	179,8	2,0	5,9	0,7	2,1	2,6	90,4	90,5	89,6	0,70	0,18660	160	70
	Q2H200L6C	Aluminium	22,00	30,0	982	48,8	214,5	1,8	5,6	0,8	2,3	2,4	90,9	91,0	90,3	0,72	0,20643	171	70
Q2E225M6B	Aluminium	30,00	40,0	975	57,0	287,6	1,9	5,7	0,6	1,7	2,5	91,7	91,6	90,7	0,83	0,49334	234	66	

DIMENSION - B3

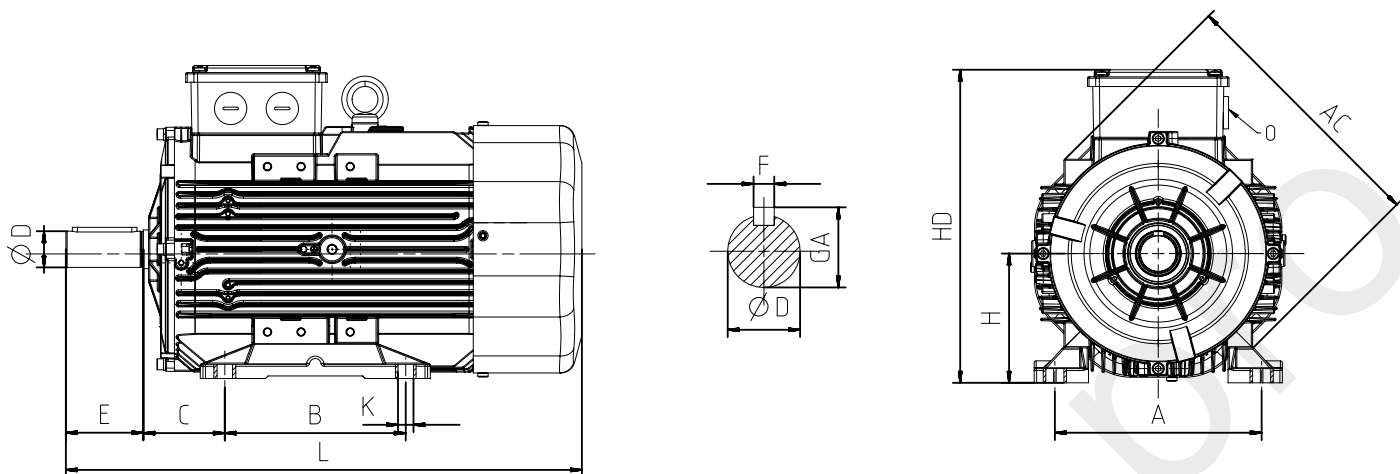

Power (kW)	Number of Poles	Motor Type	Housing Type	Main Dimensions			Foot Mounted Motors						Shaft				Bearing		Seal	
				AC	L	O	B	A	H	HD	K	C	D ⁽¹⁾	E	GA	F ⁽²⁾	Drive Side	Non drive Side	Drive Side	Non drive Side
0,12	4	Q2E63M4A	Aluminium	123	220	1xM20	80	100	63	162	7	40	11	23	12,5	4	6201-ZZ	6201-ZZ	12*22*7	12*22*7
0,18	2	Q2E63M2A	Aluminium	123	220	1xM20	80	100	63	162	7	40	11	23	12,5	4	6201-ZZ	6201-ZZ	12*22*7	12*22*7
0,18	4	Q2E63M4B	Aluminium	123	220	1xM20	80	100	63	162	7	40	11	23	12,5	4	6201-ZZ	6201-ZZ	12*22*7	12*22*7
0,25	2	Q2E63M2B	Aluminium	123	220	1xM20	80	100	63	162	7	40	11	23	12,5	4	6201-ZZ	6201-ZZ	12*22*7	12*22*7
0,25	4	Q2E71M4A	Aluminium	138	253	1xM20	90	112	71	190	7	45	14	30	16,0	5	6202-ZZ	6202-ZZ	15*24*5	15*24*5
0,37	2	Q2E71M2A	Aluminium	138	253	1xM20	90	112	71	190	7	45	14	30	16,0	5	6202-ZZ	6202-ZZ	15*24*5	15*24*5
0,37	4	Q2E71M4B	Aluminium	138	253	1xM20	90	112	71	190	7	45	14	30	16,0	5	6202-ZZ	6202-ZZ	15*24*5	15*24*5
0,55	2	Q2E71M2B	Aluminium	138	253	1xM20	90	112	71	190	7	45	14	30	16,0	5	6202-ZZ	6202-ZZ	15*24*5	15*24*5
0,55	4	Q2H80M4B	Aluminium	158	268	1xM20	100	125	80	216	10	50	19	40	21,5	6	6204-ZZ	6204-ZZ	20*30*7	20*30*7
0,75	2	Q2H80M2B	Aluminium	158	268	1xM20	100	125	80	216	10	50	19	40	21,5	6	6204-ZZ	6204-ZZ	20*30*7	20*30*7
0,75	4	Q2H80M4C	Aluminium	158	268	1xM20	100	125	80	216	10	50	19	40	21,5	6	6204-ZZ	6204-ZZ	20*30*7	20*30*7
0,75	6	Q2H90S6B	Aluminium	172	344	1xM25	100-125	140	90	223	10	56	24	50	27,0	8	6305-ZZ	6205-ZZ	25*40*7	25*40*7
1,1	2	Q2H80M2C	Aluminium	158	268	1xM20	100	125	80	216	10	50	19	40	21,5	6	6204-ZZ	6204-ZZ	20*30*7	20*30*7
1,1	4	Q2H90L4C	Aluminium	158	278	1xM25	100-125	140	90	213	10	56	24	50	27,0	8	6305-ZZ	6204-ZZ	25*40*7	20*30*7
1,1	6	Q2H90L6C	Aluminium	172	344	1xM25	100-125	140	90	223	10	56	24	50	27,0	8	6305-ZZ	6205-ZZ	25*40*7	25*40*7
1,5	2	Q2H90L2B	Aluminium	158	278	1xM25	100-125	140	90	213	10	56	24	50	27,0	8	6305-ZZ	6204-ZZ	25*40*7	20*30*7
1,5	4	Q2H90L4C	Aluminium	158	303	1xM25	100-125	140	90	213	10	56	24	50	27,0	8	6305-ZZ	6204-ZZ	25*40*7	20*30*7
1,5	6	Q2H100L6C	Aluminium	191	400	1xM25	140	160	100	243	12	63	28	60	31,0	8	6306-ZZ	6205-ZZ	30*47*7	30*47*7
2,2	2	Q2H90L2D	Aluminium	158	303	1xM25	100-125	140	90	213	10	56	24	50	27,0	8	6305-ZZ	6204-ZZ	25*40*7	20*30*7
2,2	4	Q2H100L4B	Aluminium	172	349	1xM25	140	160	100	233	12	63	28	60	31,0	8	6306-ZZ	6205-ZZ	30*47*7	25*40*7
2,2	6	Q2H112M6C	Aluminium	210	396	1xM25	140	190	112	265	12	70	28	60	31,0	8	6306-ZZ	6206-ZZ	30*47*7	30*47*7
3	2	Q2H100L2C	Aluminium	172	349	1xM25	140	160	100	233	12	63	28	60	31,0	8	6306-ZZ	6205-ZZ	30*47*7	25*40*7
3	4	Q2H100L4C	Aluminium	172	384	1xM25	140	160	100	233	12	63	28	60	31,0	8	6306-ZZ	6205-ZZ	30*47*7	25*40*7
3	6	Q2H132S6A	Aluminium	260	481	1xM32	140-178	216	132	312	12	89	38	80	41,0	10	6208-ZZ	6208-ZZ	40*62*10	40*62*10
4	2	Q2H112M2B	Aluminium	191	399	1xM25	140	190	112	254	12	70	28	60	31,0	8	6306-ZZ	6205-ZZ	30*47*7	25*40*7
4	4	Q2H112M4C	Aluminium	191	399	1xM25	140	190	112	254	12	70	28	60	31,0	8	6306-ZZ	6205-ZZ	30*47*7	25*40*7
4	6	Q2H132M6A	Aluminium	260	481	1xM32	140-178	216	132	312	12	89	38	80	41,0	10	6208-ZZ	6208-ZZ	40*62*10	40*62*10
5,5	2	Q2H132S2B	Aluminium	210	422	1xM25	140-178	216	132	283	12	89	38	80	41,0	10	6208-ZZ	6206-ZZ	40*62*10	30*47*7
5,5	4	Q2H132S4A	Aluminium	210	422	1xM25	140-178	216	132	283	12	89	38	80	41,0	10	6208-ZZ	6206-ZZ	40*62*10	30*47*7
5,5	6	Q2H132M6B	Aluminium	260	481	1xM32	140-178	216	132	312	12	89	38	80	41,0	10	6208-ZZ	6208-ZZ	40*62*10	40*62*10

(1) Tolerance DIN EN 50347 "j6" up to 28mm, "k6" above 28mm

(2) According to DIN 6885

Power (kW)	Number of Poles	Motor Type	Housing Type	Main Dimensions			Foot Mounted Motors						Shaft				Bearing		Seal	
				AC	L	O	B	A	H	HD	K	C	D ⁽¹⁾	E	GA	F ⁽²⁾	Drive Side	Non drive Side	Drive Side	Non drive Side
7,5	2	Q2H132S2C	Aluminium	210	422	1xM25	140-178	216	132	283	12	89	38	80	41,0	10	6208-ZZ	6206-ZZ	40*62*10	30*47*7
7,5	4	Q2H132M4C	Aluminium	260	481	1xM32	140-178	216	132	312	12	89	38	80	41,0	10	6208-ZZ	6208-ZZ	40*62*10	40*62*10
7,5	6	Q2H160M6B	Aluminium	305	591	1xM32	210-254	254	160	368	14,5	108	42	110	45,0	12	6309-ZZ	6209-ZZ	45*72*10	45*72*10
11	2	Q2H160M2B	Aluminium	260	520	1xM32	210-254	254	160	351	14,5	108	42	110	45,0	12	6309-ZZ	6208-ZZ	45*72*10	40*62*10
11	4	Q2H160M4C	Aluminium	260	520	1xM32	210-254	254	160	351	14,5	108	42	110	45,0	12	6309-ZZ	6208-ZZ	45*72*10	40*62*10
11	6	Q2H160L6B	Aluminium	305	591	1xM32	210-254	254	160	368	14,5	108	42	110	45,0	12	6309-ZZ	6209-ZZ	45*72*10	45*72*10
15	2	Q2H160M2C	Aluminium	260	520	1xM32	210-254	254	160	351	14,5	108	42	110	45,0	12	6309-ZZ	6208-ZZ	45*72*10	40*62*10
15	4	Q2H160L4B	Aluminium	260	520	1xM32	210-254	254	160	351	14,5	108	42	110	45,0	12	6309-ZZ	6208-ZZ	45*72*10	40*62*10
15	6	Q2H180L6A	Aluminium	349	696	1xM40	241-279	279	180	437	14,5	121	48	110	51,5	14	6310-ZZ	6310-ZZ	50*80*10	50*80*10
18,5	2	Q2H160M2D	Aluminium	260	520	1xM32	210-254	254	160	351	14,5	108	42	110	45,0	12	6309-ZZ	6208-ZZ	45*72*10	40*62*10
18,5	4	Q2H180M4A	Aluminium	305	596	1xM32	241-279	279	180	398	14,5	121	48	110	51,5	14	6310-ZZ	6209-ZZ	50*80*10	45*72*10
18,5	6	Q2H200L6B	Aluminium	349	706	1xM50	305	318	200	455	18,5	133	55	110	59,0	16	6312-ZZ	6310-ZZ	60*90*10	60*90*10
22	2	Q2H180M2A	Aluminium	305	596	1xM32	241-279	279	180	398	14,5	121	48	110	51,5	14	6310-ZZ	6209-ZZ	50*80*10	45*72*10
22	4	Q2H180M4B	Aluminium	305	596	1xM32	241-279	279	180	398	14,5	121	48	110	51,5	14	6310-ZZ	6209-ZZ	50*80*10	45*72*10
22	6	Q2H200L6C	Aluminium	349	706	1xM50	267-305	318	200	455	18,5	133	55	110	59,0	16	6312-ZZ	6310-ZZ	60*90*10	60*90*10
30	2	Q2H200L2B	Aluminium	349	706	1xM50	267-305	318	200	455	18,5	133	55	110	59,0	16	6312-ZZ	6310-ZZ	60*90*10	60*90*10
30	4	Q2H200L4C	Aluminium	349	706	1xM50	267-305	318	200	455	18,5	133	55	110	59,0	16	6312-ZZ	6310-ZZ	60*90*10	60*90*10
30	6	Q2E225M6B	Aluminium	456	765	1xM50	286-311	356	225	485	18,5	149	60	140	64,0	18	6313-ZZ	6313-ZZ	65*100*13	65*100*13
37	2	Q2H200L2C	Aluminium	349	706	1xM50	305	318	200	455	18,5	133	55	110	59,0	16	6312-ZZ	6310-ZZ	60*90*10	60*90*10
37	4	Q2E225M4A	Aluminium	456	765	1xM50	286-311	356	225	485	18,5	149	60	140	64,0	18	6313-ZZ	6313-ZZ	65*100*13	65*100*13
45	2	Q2E225M2B	Aluminium	456	735	1xM50	286-311	356	225	485	18,5	149	55	110	59,0	16	6313-ZZ	6313-ZZ	65*100*13	65*100*13
45	4	Q2E225M4B	Aluminium	456	765	1xM50	286-311	356	225	485	18,5	149	60	140	64,0	18	6313-ZZ	6313-ZZ	65*100*13	65*100*13
55	2	Q2E250M2A	Aluminium	527	886	2*M50	349	406	250	615	24	149	60	140	64,0	18	6315-ZZ	6313-ZZ	75*112*12	65*100*13
55	2	Q2E250M2A	Cast Iron	489	893	1xM50	349	406	250	616	24	149	60	140	69,0	18	6316-Z	6316-Z	80*100*10	80*100*10
55	4	Q2E250M4A	Cast Iron	489	893	1xM50	349	406	250	616	24	149	65	140	69,0	18	6316-Z	6316-Z	80*100*10	80*100*10
75	2	Q2EP280M2B	Cast Iron	489	1025	1xM50	419	457	280	647	24	190	65	140	69,0	18	6316-Z	6316-Z	80*100*10	80*100*10
75	4	Q2EP280M4B	Cast Iron	489	1025	1xM50	419	457	280	647	24	190	75	140	79,5	20	6316-Z	6316-Z	80*100*10	80*100*10
90	2	Q2EP280M2C	Cast Iron	489	1025	1xM50	419	457	280	647	24	190	65	140	69,0	18	6316-Z	6316-Z	80*100*10	80*100*10
90	4	Q2EP280M4C	Cast Iron	489	1025	1xM50	419	457	280	647	24	190	75	140	79,5	20	6316-Z	6316-Z	80*100*10	80*100*10
110	2	Q2EP315S2C	Cast Iron	630	1180	2*M63	406	508	315	845	28	216	65	140	69	18	6317	6317	85*105*5.5	85*105*5.5
110	4	Q2EP315S4C	Cast Iron	630	1210	2*M63	406	508	315	845	28	216	80	170	85	22	6319	6319	95*115*5.5	95*115*5.5
132	2	Q2EP315M2C	Cast Iron	630	1290	2*M63	457	508	315	845	28	216	65	140	69	18	6317	6317	85*105*5.5	85*105*5.5
132	4	Q2EP315M4C	Cast Iron	630	1320	2*M63	457	508	315	845	28	216	80	170	85	22	6319	6319	95*115*5.5	95*115*5.5
160	2	Q2EP315L2C	Cast Iron	630	1290	2*M63	508	508	315	845	28	216	65	140	69	18	6317	6317	85*105*5.5	85*105*5.5
160	4	Q2EP315L4C	Cast Iron	630	1320	2*M63	508	508	315	845	28	216	80	170	85	22	6319	6319	95*115*5.5	95*115*5.5
200	2	Q2EP315L2D	Cast Iron	630	1290	2*M63	508	508	315	845	28	216	65	140	69	18	6317	6317	85*105*5.5	85*105*5.5
200	4	Q2EP315L4D	Cast Iron	630	1320	2*M63	508	508	315	845	28	216	80	170	85	22	6319	6319	95*115*5.5	95*115*5.5
250	2	Q2EP355M2C	Cast Iron	710	1486	4*M63	560	610	355	956	28	254	75	140	80	20	6317	6317	85*105*5.5	85*105*5.5
250	4	Q2EP355M4C	Cast Iron	710	1517	4*M63	560	610	355	956	28	254	95	170	100	25	6322	6322	110*130*5.5	110*130*5.5
315	2	Q2EP355L2C	Cast Iron	710	1486	4*M63	630	610	355	956	28	254	75	140	80	20	6317	6317	85*105*5.5	85*105*5.5
315	4	Q2EP355L4C	Cast Iron	710	1517	4*M63	630	610	355	956	28	254	95	170	100	25	6322	6322	110*130*5.5	110*130*5.5
355	2	Q2EP355L2D	Cast Iron	710	1486	4*M63	630	610	355	956	28	254	75	140	80	20	6317	6317	85*105*5.5	85*105*5.5
355	4	Q2EP355L4D	Cast Iron	710	1517	4*M63	630	610	355	956	28	254	95	170	100	25	6322	6322	110*130*5.5	110*130*5.5

(1) Tolerance DIN EN 50347 "j6" up to 28mm, "k6" above 28mm

(2) According to DIN 6885

DIMENSION - B5, B35

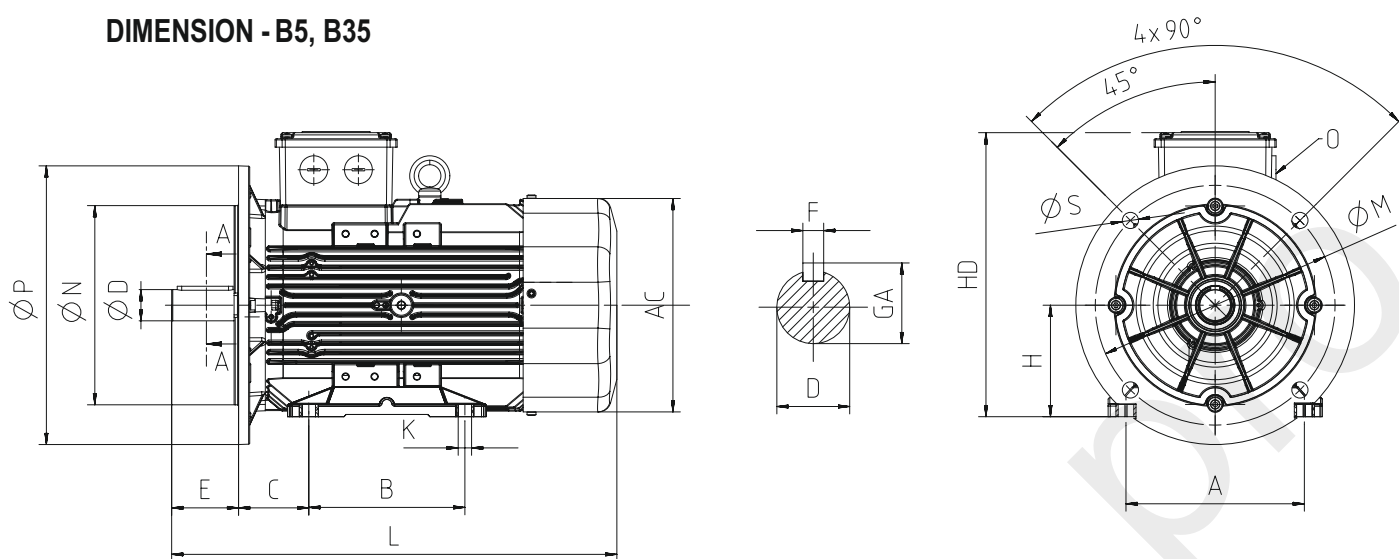

Power (kW)	Number of Poles	Motor Type	Housing Type	Main Dimensions			Foot Mounted Motors					Shaft				Bearing		Seal		Flange (FA) (B5)				
				AC	L	O	B	A	H	HD	K	D ⁽¹⁾	E	GA	F ⁽²⁾	Drive Side	Non drive Side	Drive Side	Non drive Side	P	N ⁽³⁾	M	R	S
0,12	4	Q2E63M4A	Aluminium	123	220	1xM20	80	100	63	162	7	11	23	12,5	4	6201-ZZ	6201-ZZ	12*22*7	12*22*7	140	95	115	-	10
0,18	2	Q2E63M2A	Aluminium	123	220	1xM20	80	100	63	162	7	11	23	12,5	4	6201-ZZ	6201-ZZ	12*22*7	12*22*7	140	95	115	-	10
0,18	4	Q2E63M4B	Aluminium	123	220	1xM20	80	100	63	162	7	11	23	12,5	4	6201-ZZ	6201-ZZ	12*22*7	12*22*7	140	95	115	-	10
0,25	2	Q2E63M2B	Aluminium	123	220	1xM20	80	100	63	162	7	11	23	12,5	4	6201-ZZ	6201-ZZ	12*22*7	12*22*7	140	95	115	-	10
0,25	4	Q2E71M4A	Aluminium	138	253	1xM20	90	112	71	190	7	14	30	16,0	5	6202-ZZ	6202-ZZ	15*24*5	15*24*5	160	110	130	-	10
0,37	2	Q2E71M2A	Aluminium	138	253	1xM20	90	112	71	190	7	14	30	16,0	5	6202-ZZ	6202-ZZ	15*24*5	15*24*5	160	110	130	-	10
0,37	4	Q2E71M4B	Aluminium	138	253	1xM20	90	112	71	190	7	14	30	16,0	5	6202-ZZ	6202-ZZ	15*24*5	15*24*5	160	110	130	-	10
0,55	2	Q2E71M2B	Aluminium	138	253	1xM20	90	112	71	190	7	14	30	16,0	5	6202-ZZ	6202-ZZ	15*24*5	15*24*5	160	110	130	-	10
0,55	4	Q2H80M4B	Aluminium	158	268	1xM20	100	125	80	216	10	19	40	21,5	6	6204-ZZ	6204-ZZ	20*30*7	20*30*7	200	130	165	-	12
0,75	2	Q2H80M2B	Aluminium	158	268	1xM20	100	125	80	216	10	19	40	21,5	6	6204-ZZ	6204-ZZ	20*30*7	20*30*7	200	130	165	-	12
0,75	4	Q2H80M4C	Aluminium	158	268	1xM20	100	125	80	216	10	19	40	21,5	6	6204-ZZ	6204-ZZ	20*30*7	20*30*7	200	130	165	-	12
0,75	6	Q2H90S6B	Aluminium	172	344	1xM25	100-125	140	90	223	10	24	50	27,0	8	6305-ZZ	6205-ZZ	25*40*7	25*40*7	200	130	165	-	12
1,1	2	Q2H80M2C	Aluminium	158	268	1xM20	100	125	80	216	10	19	40	21,5	6	6204-ZZ	6204-ZZ	20*30*7	20*30*7	200	130	165	-	12
1,1	4	Q2H90L4C	Aluminium	158	278	1xM25	100-125	140	90	213	10	24	50	27,0	8	6305-ZZ	6204-ZZ	25*40*7	20*30*7	200	130	165	-	12
1,1	6	Q2H90L6B	Aluminium	172	344	1xM25	100-125	140	90	223	10	24	50	27,0	8	6305-ZZ	6205-ZZ	25*40*7	25*40*7	200	130	165	-	12
1,5	2	Q2H90L2B	Aluminium	158	278	1xM25	100-125	140	90	213	10	24	50	27,0	8	6305-ZZ	6204-ZZ	25*40*7	20*30*7	200	130	165	-	12
1,5	4	Q2H90L4C	Aluminium	158	303	1xM25	100-125	140	90	213	10	24	50	27,0	8	6305-ZZ	6204-ZZ	25*40*7	20*30*7	200	130	165	-	12
1,5	6	Q2H100L6C	Aluminium	191	400	1xM25	140	160	100	243	12	28	60	31,0	8	6306-ZZ	6205-ZZ	30*47*7	30*47*7	250	180	215	-	14,5
2,2	2	Q2H90L2D	Aluminium	158	303	1xM25	100-125	140	90	213	10	24	50	27,0	8	6305-ZZ	6204-ZZ	25*40*7	20*30*7	200	130	165	-	12
2,2	4	Q2H100L4B	Aluminium	172	349	1xM25	140	160	100	233	12	28	60	31,0	8	6306-ZZ	6205-ZZ	30*47*7	25*40*7	250	180	215	-	14,5
2,2	6	Q2H112M6C	Aluminium	210	396	1xM25	140	190	112	265	12	28	60	31,0	8	6306-ZZ	6206-ZZ	30*47*7	30*47*7	250	180	215	-	14,5
3	2	Q2H100L2C	Aluminium	172	349	1xM25	140	160	100	233	12	28	60	31,0	8	6306-ZZ	6205-ZZ	30*47*7	25*40*7	250	180	215	-	14,5
3	4	Q2H100L4C	Aluminium	172	384	1xM25	140	160	100	233	12	28	60	31,0	8	6306-ZZ	6205-ZZ	30*47*7	25*40*7	250	180	215	-	14,5
3	6	Q2H132S6A	Aluminium	260	481	1xM32	140-178	216	132	312	12	38	80	41,0	10	6208-ZZ	6208-ZZ	40*62*10	40*62*10	300	230	265	-	14,5
4	2	Q2H112M2B	Aluminium	191	399	1xM25	140	190	112	254	12	28	60	31,0	8	6306-ZZ	6205-ZZ	30*47*7	25*40*7	250	180	215	-	14,5
4	4	Q2H112M4C	Aluminium	191	399	1xM25	140	190	112	254	12	28	60	31,0	8	6306-ZZ	6205-ZZ	30*47*7	25*40*7	250	180	215	-	14,5
4	6	Q2H132M6A	Aluminium	260	481	1xM32	140-178	216	132	312	12	38	80	41,0	10	6208-ZZ	6208-ZZ	40*62*10	40*62*10	300	230	265	-	14,5
5,5	2	Q2H132S2B	Aluminium	210	422	1xM25	140-178	216	132	283	12	38	80	41,0	10	6208-ZZ	6206-ZZ	40*62*10	30*47*7	300	230	265	-	14,5
5,5	4	Q2H132S4A	Aluminium	210	422	1xM25	140-178	216	132	283	12	38	80	41,0	10	6208-ZZ	6206-ZZ	40*62*10	30*47*7	300	230	265	-	14,5
5,5	6	Q2H132M6B	Aluminium	260	481	1xM32	140-178	216	132	312	12	38	80	41,0	10	6208-ZZ	6208-ZZ	40*62*10	40*62*10	300	230	265	-	14,5

(1) Tolerance DIN EN 50347 "j6" up to 28mm, "k6" above 28mm

(2) According to DIN 6885

(3) Tolerance DIN EN 50347 "j6"

Power (kW)	Number of Poles	Motor Type	Housing Type	Main Dimensions			Foot Mounted Motors					Shaft				Bearing		Seal		Flange (FA) (B5)				
				AC	L	O	B	A	H	HD	K	D ⁽¹⁾	E	GA	F ⁽²⁾	Drive Side	Non drive Side	Drive Side	Non drive Side	P	N ⁽³⁾	M	R	S
7,5	2	Q2H132S2C	Aluminium	210	422	1xM25	140-178	216	132	283	12	38	80	41,0	10	6208-ZZ	6206-ZZ	40*62*10	30*47*7	300	230	265	-	14,5
7,5	4	Q2H132M4C	Aluminium	260	481	1xM32	140-178	216	132	312	12	38	80	41,0	10	6208-ZZ	6208-ZZ	40*62*10	40*62*10	300	230	265	-	14,5
7,5	6	Q2H160M6B	Aluminium	305	591	1xM32	210-254	254	160	368	14,5	42	110	45,0	12	6309-ZZ	6209-ZZ	45*72*10	45*72*10	350	250	300	-	18,5
11	2	Q2H160M2B	Aluminium	260	520	1xM32	210-254	254	160	351	14,5	42	110	45,0	12	6309-ZZ	6208-ZZ	45*72*10	40*62*10	350	250	300	-	18,5
11	4	Q2H160M4C	Aluminium	260	520	1xM32	210-254	254	160	351	14,5	42	110	45,0	12	6309-ZZ	6208-ZZ	45*72*10	40*62*10	350	250	300	-	18,5
11	6	Q2H160L6B	Aluminium	305	591	1xM32	210-254	254	160	368	14,5	42	110	45,0	12	6309-ZZ	6209-ZZ	45*72*10	45*72*10	350	250	300	-	18,5
15	2	Q2H160M2C	Aluminium	260	520	1xM32	210-254	254	160	351	14,5	42	110	45,0	12	6309-ZZ	6208-ZZ	45*72*10	40*62*10	350	250	300	-	18,5
15	4	Q2H160L4B	Aluminium	260	520	1xM32	210-254	254	160	351	14,5	42	110	45,0	12	6309-ZZ	6208-ZZ	45*72*10	40*62*10	350	250	300	-	18,5
15	6	Q2H180L6A	Aluminium	349	696	1xM40	241-279	279	180	437	14,5	48	110	51,5	14	6310-ZZ	6310-ZZ	50*80*10	50*80*10	350	250	300	-	18,5
18,5	2	Q2H160M2D	Aluminium	260	520	1xM32	210-254	254	160	351	14,5	42	110	45,0	12	6309-ZZ	6208-ZZ	45*72*10	40*62*10	350	250	300	-	18,5
18,5	4	Q2H180M4A	Aluminium	305	596	1xM32	241-279	279	180	398	14,5	48	110	51,5	14	6310-ZZ	6209-ZZ	50*80*10	45*72*10	350	250	300	-	18,5
18,5	6	Q2H200L6B	Aluminium	349	706	1xM50	305	318	200	455	18,5	55	110	59,0	16	6312-ZZ	6310-ZZ	60*90*10	60*90*10	400	300	350	-	18,5
22	2	Q2H180M2A	Aluminium	305	596	1xM32	241-279	279	180	398	14,5	48	110	51,5	14	6310-ZZ	6209-ZZ	50*80*10	45*72*10	350	250	300	-	18,5
22	4	Q2H180M4B	Aluminium	305	596	1xM32	241-279	279	180	398	14,5	48	110	51,5	14	6310-ZZ	6209-ZZ	50*80*10	45*72*10	350	250	300	-	18,5
22	6	Q2H200L6C	Aluminium	349	706	1xM50	267-305	318	200	455	18,5	55	110	59,0	16	6312-ZZ	6310-ZZ	60*90*10	60*90*10	400	300	350	-	18,5
30	2	Q2H200L2B	Aluminium	349	706	1xM50	267-305	318	200	455	18,5	55	110	59,0	16	6312-ZZ	6310-ZZ	60*90*10	60*90*10	400	300	350	-	18,5
30	4	Q2H200L4C	Aluminium	349	706	1xM50	267-305	318	200	455	18,5	55	110	59,0	16	6312-ZZ	6310-ZZ	60*90*10	60*90*10	400	300	350	-	18,5
30	6	Q2E225M6B	Aluminium	456	765	1xM50	286-311	356	225	485	18,5	60	140	64,0	18	6313-ZZ	6313-ZZ	65*100*13	65*100*13	450	350	400	-	18,5
37	2	Q2H200L2C	Aluminium	349	706	1xM50	267-305	318	200	455	18,5	55	110	59,0	16	6312-ZZ	6310-ZZ	60*90*10	60*90*10	400	300	350	-	18,5
37	4	Q2E225M4A	Aluminium	456	765	1xM50	286-311	356	225	485	18,5	60	140	64,0	18	6313-ZZ	6313-ZZ	65*100*13	65*100*13	450	350	400	-	18,5
45	2	Q2E225M2B	Aluminium	456	735	1xM50	286-311	356	225	485	18,5	55	110	59,0	16	6313-ZZ	6313-ZZ	65*100*13	65*100*13	450	350	400	-	18,5
45	4	Q2E225M4B	Aluminium	456	765	1xM50	286-311	356	225	485	18,5	60	140	64,0	18	6313-ZZ	6313-ZZ	65*100*13	65*100*13	450	350	400	-	18,5
55	2	Q2E250M2A	Aluminium	527	886	2*M50	349	406	250	615	24	60	140	18	64	6315-ZZ	6313-ZZ	75*112*12	65*100*13	550	450	500	-	18,5
55	2	Q2E250M2A	Cast Iron	489	893	1xM50	349	406	250	616	24	60	140	69,0	18	6316-Z	6316-Z	80*100*10	80*100*10	550	450	500	-	18,5
55	4	Q2E250M4A	Cast Iron	489	893	1xM50	349	406	250	616	24	65	140	69,0	18	6316-Z	6316-Z	80*100*10	80*100*10	550	450	500	-	18,5
75	2	Q2EP280M2B	Cast Iron	489	1025	1xM50	419	457	280	647	24	65	140	69,0	18	6316-Z	6316-Z	80*100*10	80*100*10	550	450	500	-	18,5
75	4	Q2EP280M4B	Cast Iron	489	1025	1xM50	419	457	280	647	24	75	140	79,5	20	6316-Z	6316-Z	80*100*10	80*100*10	550	450	500	-	18,5
90	2	Q2EP280M2C	Cast Iron	489	1025	1xM50	419	457	280	647	24	65	140	69,0	18	6316-Z	6316-Z	80*100*10	80*100*10	550	450	500	-	18,5
90	4	Q2EP280M4C	Cast Iron	489	1025	1xM50	419	457	280	647	24	75	140	79,5	20	6316-Z	6316-Z	80*100*10	80*100*10	550	450	500	-	18,5
110	2	Q2EP315S2C	Cast Iron	630	1180	2*M63	406	508	315	845	28	216	65	140	69	6317	6317	85*105*5.5	85*105*5.5	660	550	600	-	24
110	4	Q2EP315S4C	Cast Iron	630	1210	2*M63	406	508	315	845	28	216	80	170	85	6319	6319	95*115*5.5	95*115*5.5	660	550	600	-	24
132	2	Q2EP315M2C	Cast Iron	630	1290	2*M63	457	508	315	845	28	216	65	140	69	6317	6317	85*105*5.5	85*105*5.5	660	550	600	-	24
132	4	Q2EP315M4C	Cast Iron	630	1320	2*M63	457	508	315	845	28	216	80	170	85	6319	6319	95*115*5.5	95*115*5.5	660	550	600	-	24
160	2	Q2EP315L2C	Cast Iron	630	1290	2*M63	508	508	315	845	28	216	65	140	69	6317	6317	85*105*5.5	85*105*5.5	660	550	600	-	24
160	4	Q2EP315L4C	Cast Iron	630	1320	2*M63	508	508	315	845	28	216	80	170	85	6319	6319	95*115*5.5	95*115*5.5	660	550	600	-	24
200	2	Q2EP315L2D	Cast Iron	630	1290	2*M63	508	508	315	845	28	216	65	140	69	6317	6317	85*105*5.5	85*105*5.5	660	550	600	-	24
200	4	Q2EP315L4D	Cast Iron	630	1320	2*M63	508	508	315	845	28	216	80	170	85	6319	6319	95*115*5.5	95*115*5.5	660	550	600	-	24
250	2	Q2EP355M2C	Cast Iron	710	1486	4*M63	560	610	355	956	28	254	75	140	80	6317	6317	85*105*5.5	85*105*5.5	800	680	740	-	24
250	4	Q2EP355M4C	Cast Iron	710	1517	4*M63	560	610	355	956	28	254	95	170	100	6322	6322	110*130*5.5	110*130*5.5	800	680	740	-	24
315	2	Q2EP355L2C	Cast Iron	710	1486	4*M63	630	610	355	956	28	254	75	140	80	6317	6317	85*105*5.5	85*105*5.5	800	680	740	-	24
315	4	Q2EP355L4C	Cast Iron	710	1517	4*M63	630	610	355	956	28	254	95	170	100	6322	6322	110*130*5.5	110*130*5.5	800	680	740	-	24
355	2	Q2EP355L2D	Cast Iron	710	1486	4*M63	630	610	355	956	28	254	75	140	80	6317	6317	85*105*5.5	85*105*5.5	800	680	740	-	24
355	4	Q2EP355L4D	Cast Iron	710	1517	4*M63	630	610	355	956	28	254	95	170	100	6322	6322	110*130*5.5	110*130*5.5	800	680	740	-	24

DIMENSION - B14a, B34a

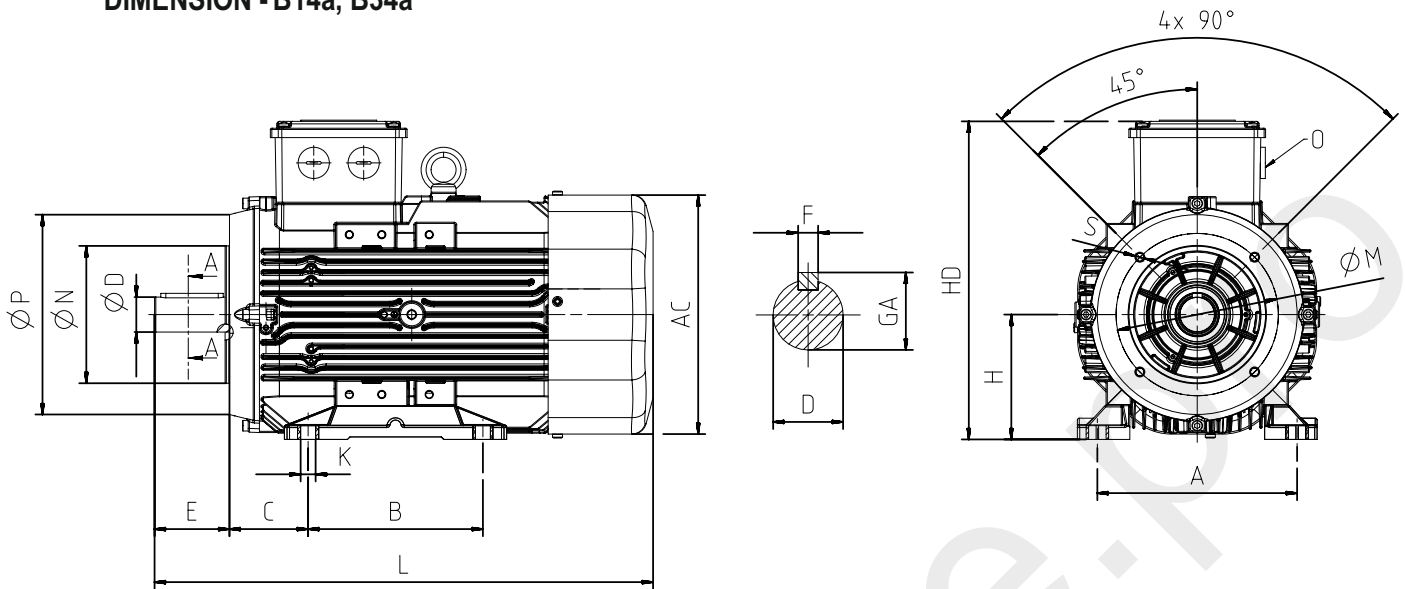

Power (kW)	Number of Poles	Motor Type	Housing Type	Main Dimensions			Foot Mounted Motors					Shaft				Bearing		Seal		Flange (FA) (B5)				
				AC	L	O	B	A	H	HD	K	D ⁽¹⁾	E	GA	F ⁽²⁾	Drive Side	Non drive Side	Drive Side	Non drive Side	P	N ⁽³⁾	M	R	S
0,12	4	Q2E63M4A	Aluminium	123	220	1xM20	80	100	63	162	7	11	23	12,5	4	6201-ZZ	6201-ZZ	12*22*7	12*22*7	90	60	75	-	M5
0,18	2	Q2E63M2A	Aluminium	123	220	1xM20	80	100	63	162	7	11	23	12,5	4	6201-ZZ	6201-ZZ	12*22*7	12*22*7	90	60	75	-	M5
0,18	4	Q2E63M4B	Aluminium	123	220	1xM20	80	100	63	162	7	11	23	12,5	4	6201-ZZ	6201-ZZ	12*22*7	12*22*7	90	60	75	-	M5
0,25	2	Q2E63M2B	Aluminium	123	220	1xM20	80	100	63	162	7	11	23	12,5	4	6201-ZZ	6201-ZZ	12*22*7	12*22*7	90	60	75	-	M5
0,25	4	Q2E71M4A	Aluminium	138	253	1xM20	90	112	71	190	7	14	30	16,0	5	6202-ZZ	6202-ZZ	15*24*5	15*24*5	105	70	85	-	M6
0,37	2	Q2E71M2A	Aluminium	138	253	1xM20	90	112	71	190	7	14	30	16,0	5	6202-ZZ	6202-ZZ	15*24*5	15*24*5	105	70	85	-	M6
0,37	4	Q2E71M4B	Aluminium	138	253	1xM20	90	112	71	190	7	14	30	16,0	5	6202-ZZ	6202-ZZ	15*24*5	15*24*5	105	70	85	-	M6
0,55	2	Q2E71M2B	Aluminium	138	253	1xM20	90	112	71	190	7	14	30	16,0	5	6202-ZZ	6202-ZZ	15*24*5	15*24*5	105	70	85	-	M6
0,55	4	Q2H80M4B	Aluminium	158	268	1xM20	100	125	80	216	10	19	40	21,5	6	6204-ZZ	6204-ZZ	20*30*7	20*30*7	120	80	100	-	M6
0,75	2	Q2H80M2B	Aluminium	158	268	1xM20	100	125	80	216	10	19	40	21,5	6	6204-ZZ	6204-ZZ	20*30*7	20*30*7	120	80	100	-	M6
0,75	4	Q2H80M4C	Aluminium	158	268	1xM20	100	125	80	216	10	19	40	21,5	6	6204-ZZ	6204-ZZ	20*30*7	20*30*7	120	80	100	-	M6
0,75	6	Q2H90S6B	Aluminium	172	344	1xM25	100-125	140	90	223	10	24	50	27,0	8	6305-ZZ	6205-ZZ	25*40*7	25*40*7	140	95	115	-	M8
1,1	2	Q2H80M2C	Aluminium	158	268	1xM20	100	125	80	216	10	19	40	21,5	6	6204-ZZ	6204-ZZ	20*30*7	20*30*7	120	80	100	-	M6
1,1	4	Q2H90L4C	Aluminium	158	278	1xM25	100-125	140	90	213	10	24	50	27,0	8	6305-ZZ	6204-ZZ	25*40*7	20*30*7	140	95	115	-	M8
1,1	6	Q2H90L6C	Aluminium	172	344	1xM25	100-125	140	90	223	10	24	50	27,0	8	6305-ZZ	6205-ZZ	25*40*7	25*40*7	140	95	115	-	M8
1,5	2	Q2H90L2C	Aluminium	158	278	1xM25	100-125	140	90	213	10	24	50	27,0	8	6305-ZZ	6204-ZZ	25*40*7	20*30*7	140	95	115	-	M8
1,5	4	Q2H90L4C	Aluminium	158	303	1xM25	100-125	140	90	213	10	24	50	27,0	8	6305-ZZ	6204-ZZ	25*40*7	20*30*7	140	95	115	-	M8
1,5	6	Q2H100L6C	Aluminium	191	400	1xM25	140	160	100	243	12	28	60	31,0	8	6306-ZZ	6205-ZZ	30*47*7	30*47*7	160	110	130	-	M8
2,2	2	Q2H90L2D	Aluminium	158	303	1xM25	100-125	140	90	213	10	24	50	27,0	8	6305-ZZ	6204-ZZ	25*40*7	20*30*7	140	95	115	-	M8
2,2	4	Q2H100L4B	Aluminium	172	349	1xM25	140	160	100	233	12	28	60	31,0	8	6306-ZZ	6205-ZZ	30*47*7	25*40*7	160	110	130	-	M8
2,2	6	Q2H112M6C	Aluminium	210	396	1xM25	140	190	112	265	12	28	60	31,0	8	6306-ZZ	6206-ZZ	30*47*7	30*47*7	160	110	130	-	M8
3	2	Q2H100L2C	Aluminium	172	349	1xM25	140	160	100	233	12	28	60	31,0	8	6306-ZZ	6205-ZZ	30*47*7	25*40*7	160	110	130	-	M8
3	4	Q2H100L4C	Aluminium	172	384	1xM25	140	160	100	233	12	28	60	31,0	8	6306-ZZ	6205-ZZ	30*47*7	25*40*7	160	110	130	-	M8
3	6	Q2H132S6A	Aluminium	260	481	1xM32	140-178	216	132	312	12	38	80	41,0	10	6208-ZZ	6208-ZZ	40*62*10	40*62*10	200	130	165	-	M10
4	2	Q2H112M2B	Aluminium	191	399	1xM25	140	190	112	254	12	28	60	31,0	8	6306-ZZ	6205-ZZ	30*47*7	25*40*7	160	110	130	-	M8
4	4	Q2H112M4C	Aluminium	191	399	1xM25	140	190	112	254	12	28	60	31,0	8	6306-ZZ	6205-ZZ	30*47*7	25*40*7	160	110	130	-	M8
4	6	Q2H132M6A	Aluminium	260	481	1xM32	140-178	216	132	312	12	38	80	41,0	10	6208-ZZ	6208-ZZ	40*62*10	40*62*10	200	130	165	-	M10
5,5	2	Q2H132S2B	Aluminium	210	422	1xM25	140-178	216	132	283	12	38	80	41,0	10	6208-ZZ	6206-ZZ	40*62*10	30*47*7	200	130	165	-	M10
5,5	4	Q2H132S4A	Aluminium	210	422	1xM25	140-178	216	132	283	12	38	80	41,0	10	6208-ZZ	6206-ZZ	40*62*10	30*47*7	200	130	165	-	M10
5,5	6	Q2H132M6B	Aluminium	260	481	1xM32	140-178	216	132	312	12	38	80	41,0	10	6208-ZZ	6208-ZZ	40*62*10	40*62*10	200	130	165	-	M10
7,5	2	Q2H132S2C	Aluminium	210	422	1xM25	140-178	216	132	283	12	38	80	41,0	10	6208-ZZ	6206-ZZ	40*62*10	30*47*7	200	130	165	-	M10
7,5	4	Q2H132M4C	Aluminium	260	481	1xM32	140-178	216	132	312	12	38	80	41,0	10	6208-ZZ	6208-ZZ	40*62*10	40*62*10	200	130	165	-	M10

(1) Tolerance DIN EN 50347 "j6" up to 28mm, "k6" above 28mm

(2) According to DIN 6885

(3) Tolerance DIN EN 50347 "j6"

DIMENSION - B14b, B34b

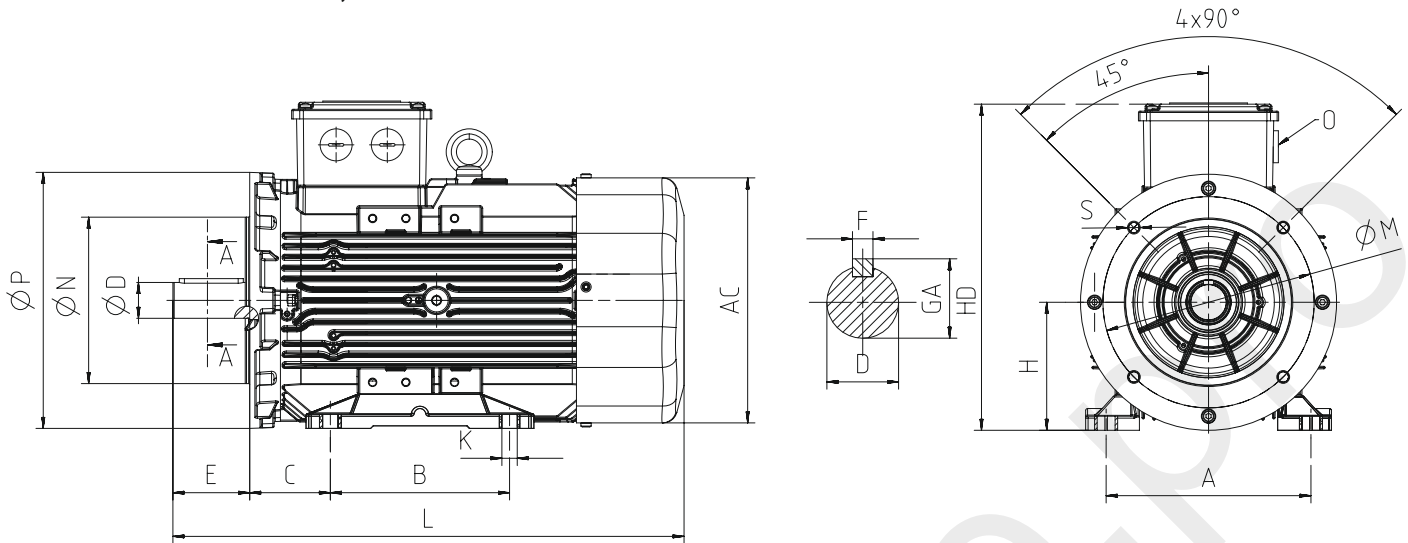

Power (kW)	Number of Poles	Motor Type	Housing Type	Main Dimensions			Foot Mounted Motors					Shaft				Bearing		Seal		Flange (FA) (B5)				
				AC	L	O	B	A	H	HD	K	D ⁽¹⁾	E	GA	F ⁽²⁾	Drive Side	Non drive Side	Drive Side	Non drive Side	P	N ⁽³⁾	M	R	S
0,12	4	Q2E63M4A	Aluminium	123	220	1xM20	80	100	63	162	7	11	23	12,5	4	6201-ZZ	6201-ZZ	12*22*7	12*22*7	120	80	100	-	M6
0,18	2	Q2E63M2A	Aluminium	123	220	1xM20	80	100	63	162	7	11	23	12,5	4	6201-ZZ	6201-ZZ	12*22*7	12*22*7	120	80	100	-	M6
0,18	4	Q2E63M4B	Aluminium	123	220	1xM20	80	100	63	162	7	11	23	12,5	4	6201-ZZ	6201-ZZ	12*22*7	12*22*7	120	80	100	-	M6
0,25	2	Q2E63M2B	Aluminium	123	220	1xM20	80	100	63	162	7	11	23	12,5	4	6201-ZZ	6201-ZZ	12*22*7	12*22*7	120	80	100	-	M6
0,25	4	Q2E71M4A	Aluminium	138	253	1xM20	90	112	71	190	7	14	30	16,0	5	6202-ZZ	6202-ZZ	15*24*5	15*24*5	140	95	115	-	M8
0,37	2	Q2E71M2A	Aluminium	138	253	1xM20	90	112	71	190	7	14	30	16,0	5	6202-ZZ	6202-ZZ	15*24*5	15*24*5	140	95	115	-	M8
0,37	4	Q2E71M4B	Aluminium	138	253	1xM20	90	112	71	190	7	14	30	16,0	5	6202-ZZ	6202-ZZ	15*24*5	15*24*5	140	95	115	-	M8
0,55	2	Q2E71M2B	Aluminium	138	253	1xM20	90	112	71	190	7	14	30	16,0	5	6202-ZZ	6202-ZZ	15*24*5	15*24*5	140	95	115	-	M8
0,55	4	Q2H80M4B	Aluminium	158	268	1xM20	100	125	80	216	10	19	40	21,5	6	6204-ZZ	6204-ZZ	20*30*7	20*30*7	160	110	130	-	M8
0,75	2	Q2H80M2B	Aluminium	158	268	1xM20	100	125	80	216	10	19	40	21,5	6	6204-ZZ	6204-ZZ	20*30*7	20*30*7	160	110	130	-	M8
0,75	4	Q2H80M4C	Aluminium	158	268	1xM20	100	125	80	216	10	19	40	21,5	6	6204-ZZ	6204-ZZ	20*30*7	20*30*7	160	110	130	-	M8
0,75	6	Q2H90S6B	Aluminium	172	344	1xM25	100-125	140	90	223	10	24	50	27,0	8	6305-ZZ	6205-ZZ	25*40*7	25*40*7	160	110	130	-	M8
1,1	2	Q2H80M2C	Aluminium	158	268	1xM20	100	125	80	216	10	19	40	21,5	6	6204-ZZ	6204-ZZ	20*30*7	20*30*7	160	110	130	-	M8
1,1	4	Q2H90L4C	Aluminium	158	278	1xM25	100-125	140	90	213	10	24	50	27,0	8	6305-ZZ	6204-ZZ	25*40*7	20*30*7	160	110	130	-	M8
1,1	6	Q2H90L6C	Aluminium	172	344	1xM25	100-125	140	90	223	10	24	50	27,0	8	6305-ZZ	6205-ZZ	25*40*7	25*40*7	160	110	130	-	M8
1,5	2	Q2H90L2B	Aluminium	158	278	1xM25	100-125	140	90	213	10	24	50	27,0	8	6305-ZZ	6204-ZZ	25*40*7	20*30*7	160	110	130	-	M8
1,5	4	Q2H90L4C	Aluminium	158	303	1xM25	100-125	140	90	213	10	24	50	27,0	8	6305-ZZ	6204-ZZ	25*40*7	20*30*7	160	110	130	-	M8
1,5	6	Q2H100L6C	Aluminium	191	400	1xM25	140	160	100	243	12	28	60	31,0	8	6306-ZZ	6205-ZZ	30*47*7	30*47*7	200	130	165	-	M10
2,2	2	Q2H90L2D	Aluminium	158	303	1xM25	100-125	140	90	213	10	24	50	27,0	8	6305-ZZ	6204-ZZ	25*40*7	20*30*7	160	110	130	-	M8
2,2	4	Q2H100L4B	Aluminium	172	349	1xM25	140	160	100	233	12	28	60	31,0	8	6306-ZZ	6205-ZZ	30*47*7	25*40*7	200	130	165	-	M10
2,2	6	Q2H112M6C	Aluminium	210	396	1xM25	140	190	112	265	12	28	60	31,0	8	6306-ZZ	6206-ZZ	30*47*7	30*47*7	200	130	165	-	M10
3	2	Q2H100L2C	Aluminium	172	349	1xM25	140	160	100	233	12	28	60	31,0	8	6306-ZZ	6205-ZZ	30*47*7	25*40*7	200	130	165	-	M10
3	4	Q2H100L4C	Aluminium	172	384	1xM25	140	160	100	233	12	28	60	31,0	8	6306-ZZ	6205-ZZ	30*47*7	25*40*7	200	130	165	-	M10
3	6	Q2H132S6A	Aluminium	260	481	1xM32	140-178	216	132	312	12	38	80	41,0	10	6208-ZZ	6208-ZZ	40*62*10	40*62*10	250	180	215	-	M12
4	2	Q2H112M2B	Aluminium	191	399	1xM25	140	190	112	254	12	28	60	31,0	8	6306-ZZ	6205-ZZ	30*47*7	25*40*7	200	130	165	-	M10
4	4	Q2H112M4C	Aluminium	191	399	1xM25	140	190	112	254	12	28	60	31,0	8	6306-ZZ	6205-ZZ	30*47*7	25*40*7	200	130	165	-	M10
4	6	Q2H132M6A	Aluminium	260	481	1xM32	140-178	216	132	312	12	38	80	41,0	10	6208-ZZ	6208-ZZ	40*62*10	40*62*10	250	180	215	-	M12
5,5	2	Q2H132S2B	Aluminium	210	422	1xM25	140-178	216	132	283	12	38	80	41,0	10	6208-ZZ	6206-ZZ	40*62*10	30*47*7	250	180	215	-	M12
5,5	4	Q2H132S4A	Aluminium	210	422	1xM25	140-178	216	132	283	12	38	80	41,0	10	6208-ZZ	6206-ZZ	40*62*10	30*47*7	250	180	215	-	M12
5,5	6	Q2H132M6B	Aluminium	260	481	1xM32	140-178	216	132	312	12	38	80	41,0	10	6208-ZZ	6208-ZZ	40*62*10	40*62*10	250	180	215	-	M12
7,5	2	Q2H132S2C	Aluminium	210	422	1xM25	140-178	216	132	283	12	38	80	41,0	10	6208-ZZ	6206-ZZ	40*62*10	30*47*7	250	180	215	-	M12
7,5	4	Q2H132M4C	Aluminium	260	481	1xM32	140-178	216	132	312	12	38	80	41,0	10	6208-ZZ	6208-ZZ	40*62*10	40*62*10	250	180	215	-	M12

(1) Tolerance DIN EN 50347 "j6" up to 28mm, "k6" above 28mm

(2) According to DIN 6885

(3) Tolerance DIN EN 50347 "j6"

ELECTRICAL CHARACTERISTICS AT 50 Hz

MOTOR TYPE	HOUSING TYPE	RATED VALUES					STARTING VALUES					Breakdown Torque Ratio Mk/ Mn	EFFICIENCY*			Cos φ	J kgm ²	Weight (B3) kg	Sound Pressure Level dBA**
		POWER		SPEED	CURRENT	TORQUE	CURRENT		TORQUE		η%		4/4	3/4	2/4				
		kW	HP	rpm	A	Nm	I _A / I _N λ / Δ	I _Δ / I _N λ / Δ	M _A / M _N λ / Δ	M _Δ / M _N λ / Δ									
2 pole 3000 rpm																			
230/400V	Q2H80M2D	Aluminium	1,5	2,0	2875	3,8	5,0	8,0	-	3,9	-	4,4	81,3	80,4	76,6	0,74	0,00169	12	58
	Q2H80M2DE	Aluminium	2,2	3,0	2870	4,7	7,3	9,1	-	3,9	-	4,4	83,2	82,8	81,3	0,83	0,00224	16	59
	Q2H90L2D	Aluminium	3,0	4,0	2887	6,3	9,9	7,3	-	2,4	-	2,9	84,6	85,4	84,2	0,83	0,00283	19	61
400/690V	Q2HS100L2C	Aluminium	4,0	5,5	2913	8,2	13,2	3,6	10,8	1,4	4,2	4,8	85,8	87,0	86,1	0,82	0,00381	24	66
	Q2HS112M2C	Aluminium	5,5	7,5	2910	10,6	18,1	3,6	10,9	1,3	3,8	4,5	87,0	87,5	86,2	0,86	0,00637	29	68
	Q2HS112M2D	Aluminium	7,5	10,0	2895	14,1	24,8	3,4	10,3	1,3	3,9	4,6	88,1	89,0	88,7	0,88	0,00751	30	68
	Q2H132M2A	Aluminium	11,0	15,0	2923	21,3	35,9	3,1	9,2	1,1	3,3	4,8	89,4	89,9	88,4	0,83	0,03489	57	69
	Q2H132M2B	Aluminium	15,0	20,0	2915	30,0	49,2	3,2	9,6	1,3	3,9	5,1	90,3	90,6	89,6	0,80	0,03490	65	69
	Q2H132M2C	Aluminium	18,5	25,0	2930	30,8	60,3	2,7	8,0	0,6	1,9	3,6	90,9	91,7	91,1	0,95	0,04685	77	70
	Q2H160L2C	Aluminium	22,0	30,0	2955	40,9	71,2	3,5	10,4	1,2	3,6	5,2	91,3	92,0	90,7	0,84	0,04808	96	71
	Q2H180M2B	Aluminium	30,0	37,0	2955	51,5	97,1	2,8	8,5	0,8	2,4	3,6	92,0	92,5	91,8	0,91	0,08643	128	77
	Q2H180M2C	Aluminium	37,0	50,0	2965	66,2	119,6	3,4	10,1	1,0	3,1	4,5	92,5	92,5	91,2	0,87	0,10277	145	77
	Q2H200L2D	Aluminium	45,0	60,0	2960	76,0	145,1	3,3	9,8	0,9	2,8	5,3	92,9	93,4	92,7	0,92	0,11910	166	78
	Q2E225M2C	Aluminium	55,0	75,0	2970	96,6	176,9	3,5	10,6	1,0	3,0	7,1	93,2	93,7	92,4	0,88	0,29500	244	80
	Q2EP250M2C	Cast Iron	75,0	100,0	2975	127,9	240,8	3,5	10,6	0,9	2,7	6,8	93,8	93,7	92,5	0,92	0,54000	565	81
Q2EP280M2D	Cast Iron	110,0	150,0	2980	192,0	352,4	2,6	7,7	1,0	2,9	3,4	94,1	93,9	92,9	0,88	0,70200	640	82	
4 pole 1500 rpm																			
230/400V	Q2H80M4D	Aluminium	1,1	1,5	1430	2,5	7,4	5,7	-	2,2	-	2,6	81,4	82,4	81,6	0,80	0,00260	12	48
	Q2H80M4DE	Aluminium	1,5	2,0	1427	3,3	10,0	6,4	-	2,5	-	3,1	82,8	84,2	83,7	0,79	0,00306	14	48
	Q2H90L4D	Aluminium	2,2	3,0	1437	5,3	14,6	7,6	-	3,6	-	4,2	84,3	84,1	81,5	0,72	0,00526	18	52
	Q2H90L4DE	Aluminium	3,0	4,0	1440	7,4	20,0	6,5	-	3,3	-	3,7	85,5	85,3	83,0	0,70	0,00690	25	53
	Q2H100L4D	Aluminium	4,0	5,5	1440	8,7	26,6	2,7	8,0	1,1	3,2	3,8	86,6	85,7	83,5	0,78	0,01058	31	57
	Q2H112M4D	Aluminium	5,5	7,5	1445	11,6	35,5	2,7	8,0	1,0	3,0	3,8	87,7	88,3	87,3	0,79	0,01382	38	58
400/690V	Q2H132M4D	Aluminium	11,0	15,0	1468	21,6	71,5	2,6	7,9	0,7	2,1	3,6	89,8	91,1	90,3	0,81	0,05440	76	61
	Q2H132M4E	Aluminium	15,0	20,0	1462	29,8	98,0	2,6	7,8	0,6	1,8	3,4	90,6	91,4	90,9	0,80	0,05940	81	63
	Q2H160L4B	Aluminium	18,5	25,0	1470	36,0	120,2	2,3	6,8	0,7	2,2	2,9	91,2	92,0	91,6	0,81	0,09005	101	57
	Q2H160L4C	Aluminium	22,0	30,0	1462	41,8	143,8	1,8	5,5	0,6	1,9	2,8	91,6	92,9	93,3	0,84	0,11068	115	58
	Q2H180L4C	Aluminium	30,0	40,0	1475	55,3	194,6	2,7	8,2	0,9	2,7	3,5	92,0	91,9	91,4	0,85	0,14694	143	70
	Q2H200L4D	Aluminium	37,0	50,0	1476	72,5	240,8	2,8	8,3	0,9	2,8	3,7	92,7	93,2	92,8	0,79	0,26440	177	71
Q2EP250M4E	Cast Iron	75,0	100,0	1485	134,2	485,7	2,6	7,8	1,0	2,9	3,4	94,0	93,9	93,2	0,86	1,06110	610	72	
Q2EP280M4E	Cast Iron	110,0	150,0	1485	200,3	714,0	2,6	7,9	1,0	2,9	3,4	94,5	94,3	93,1	0,84	1,25200	688	73	

* According to IEC 60034-2-1

** The sound pressure measurements are taken 1m away from the motor

*** Tolerance +3 dBA

DIMENSION - B3

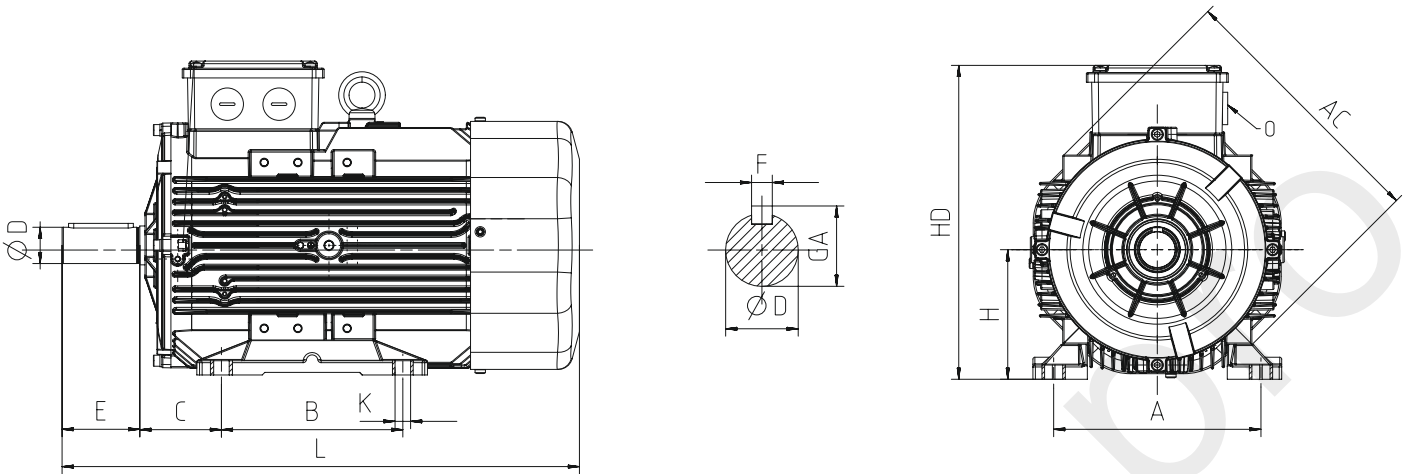

Power (kW)	Number of Poles	Motor Type	Housing Type	Main Dimensions			Foot Mounted Motors						Shaft				Bearing		Seal	
				AC	L	O	B	A	H	HD	K	C	D ⁽¹⁾	E	GA	F ⁽²⁾	Drive Side	Non drive Side	Drive Side	Non drive Side
1,1	4	Q2H80M4D	Aluminium	158	268	1xM20	100	125	80	216	10	50	19	40	21,5	6	6204-ZZ	6204-ZZ	20*30*7	20*30*7
1,5	2	Q2H80M2D	Aluminium	158	268	1xM20	100	125	80	216	10	50	19	40	21,5	6	6204-ZZ	6204-ZZ	20*30*7	20*30*7
1,5	4	Q2H80M4DE	Aluminium	158	268	1xM20	100	125	80	216	10	50	19	40	21,5	6	6204-ZZ	6204-ZZ	20*30*7	20*30*7
2,2	2	Q2H80M2DE	Aluminium	158	268	1xM20	100	125	80	216	10	50	19	40	21,5	6	6204-ZZ	6204-ZZ	20*30*7	20*30*7
2,2	4	Q2H90L4D	Aluminium	172	344	1xM25	100-125	140	90	223	10	56	24	50	27,0	8	6305-ZZ	6205-ZZ	25*40*7	25*40*7
3,0	2	Q2H90L2D	Aluminium	172	344	1xM25	100-125	140	90	223	10	56	24	50	27,0	8	6305-ZZ	6205-ZZ	25*40*7	25*40*7
3,0	4	Q2H90L4DE	Aluminium	172	379	1xM25	100-125	140	90	223	10	56	24	50	27,0	8	6305-ZZ	6205-ZZ	25*40*7	25*40*7
4,0	2	Q2HS100L2C	Aluminium	172	384	1xM25	140	160	100	233	12	63	28	60	31,0	8	6306-ZZ	6205-ZZ	30*47*7	25*40*7
4,0	4	Q2H100L4D	Aluminium	191	400	1xM25	140	160	100	243	12	63	28	60	31,0	8	6306-ZZ	6205-ZZ	30*47*7	25*40*7
5,5	2	Q2HS112M2C	Aluminium	191	399	1xM25	140	190	112	254	12	70	28	60	31,0	8	6306-ZZ	6205-ZZ	30*47*7	25*40*7
5,5	4	Q2H112M4D	Aluminium	210	421	1xM25	140	190	112	265	12	70	28	60	31,0	8	6306-ZZ	6206-ZZ	30*47*7	30*47*7
7,5	2	Q2HS112M2D	Aluminium	191	421	1xM25	140	190	112	254	12	70	28	60	31,0	8	6306-ZZ	6205-ZZ	30*47*7	25*40*7
11,0	2	Q2H132M2A	Aluminium	260	481	1xM32	140-178	216	132	312	12	89	38	80	41,0	10	6208-ZZ	6208-ZZ	40*62*10	40*62*10
11,0	4	Q2H132M4D	Aluminium	260	481	1xM32	140-178	216	132	312	12	89	38	80	41,0	10	6208-ZZ	6208-ZZ	40*62*10	40*62*10
15,0	2	Q2H132M2B	Aluminium	260	481	1xM32	140-178	216	132	312	12	89	38	80	41,0	10	6208-ZZ	6208-ZZ	40*62*10	40*62*10
15,0	4	Q2H132M4E	Aluminium	260	539	1xM32	140-178	216	132	312	12	89	38	80	41,0	10	6208-ZZ	6208-ZZ	40*62*10	40*62*10
18,5	2	Q2H132M2C	Aluminium	260	539	1xM32	140-178	216	132	312	12	89	38	80	41,0	10	6208-ZZ	6208-ZZ	40*62*10	40*62*10
18,5	4	Q2H160L4B	Aluminium	305	591	1xM32	210-254	254	160	368	14,5	108	42	110	45,0	12	6309-ZZ	6209-ZZ	45*72*10	45*72*10
22,0	2	Q2H160L2C	Aluminium	305	591	1xM32	210-254	254	160	368	14,5	108	42	110	45,0	12	6309-ZZ	6209-ZZ	45*72*10	45*72*10
22,0	4	Q2H160L4C	Aluminium	305	591	1xM32	210-254	254	160	368	14,5	108	42	110	45,0	12	6309-ZZ	6209-ZZ	45*72*10	45*72*10
30,0	2	Q2H180M2B	Aluminium	349	696	1xM40	241-279	279	180	437	14,5	121	48	110	51,5	14	6310-ZZ	6310-ZZ	50*80*10	50*80*10
30,0	4	Q2H180L4C	Aluminium	349	696	1xM40	241-279	279	180	437	14,5	121	48	110	51,5	14	6310-ZZ	6310-ZZ	50*80*10	50*80*10
37,0	2	Q2H180M2C	Aluminium	349	696	1xM40	241-279	279	180	437	14,5	121	48	110	51,5	14	6310-ZZ	6310-ZZ	50*80*10	50*80*10
37,0	4	Q2H200L4D	Aluminium	349	759	1xM50	267-305	318	200	455	18,5	133	55	110	59,0	16	6312-ZZ	6310-ZZ	60*90*10	60*90*10
45,0	2	Q2H200L2D	Aluminium	349	759	1xM50	267-305	318	200	455	18,5	133	55	110	59,0	16	6312-ZZ	6310-ZZ	60*90*10	60*90*10
55,0	2	Q2E225M2C	Aluminium	456	735	1xM50	286-311	356	225	485	18,5	149	55	110	59,0	16	6313-ZZ	6313-ZZ	65*100*13	65*100*13
75,0	2	Q2EP250M2C	Cast Iron	489	893	1xM50	311-349	406	250	616	30	149	60	140	64,0	18	6316-Z	6316-Z	80*100*10	80*100*10
75,0	4	Q2EP250M4E	Cast Iron	489	893	1xM50	311-349	406	250	616	30	149	65	140	69,0	18	6316-Z	6316-Z	80*100*10	80*100*10
110,0	2	Q2EP280M2D	Cast Iron	489	1025	1xM50	368-419	457	280	647	24	190	65	140	69,0	18	6316-Z	6316-Z	80*100*10	80*100*10
110,0	4	Q2EP280M4E	Cast Iron	489	1025	1xM50	368-419	457	280	647	24	130	75	140	79,5	20	6316-Z	6316-Z	80*100*10	80*100*10

(1) Tolerance DIN EN 50347 "j6" up to 28mm, "k6" above 28mm

(2) According to DIN 6885

DIMENSION - B5, B35

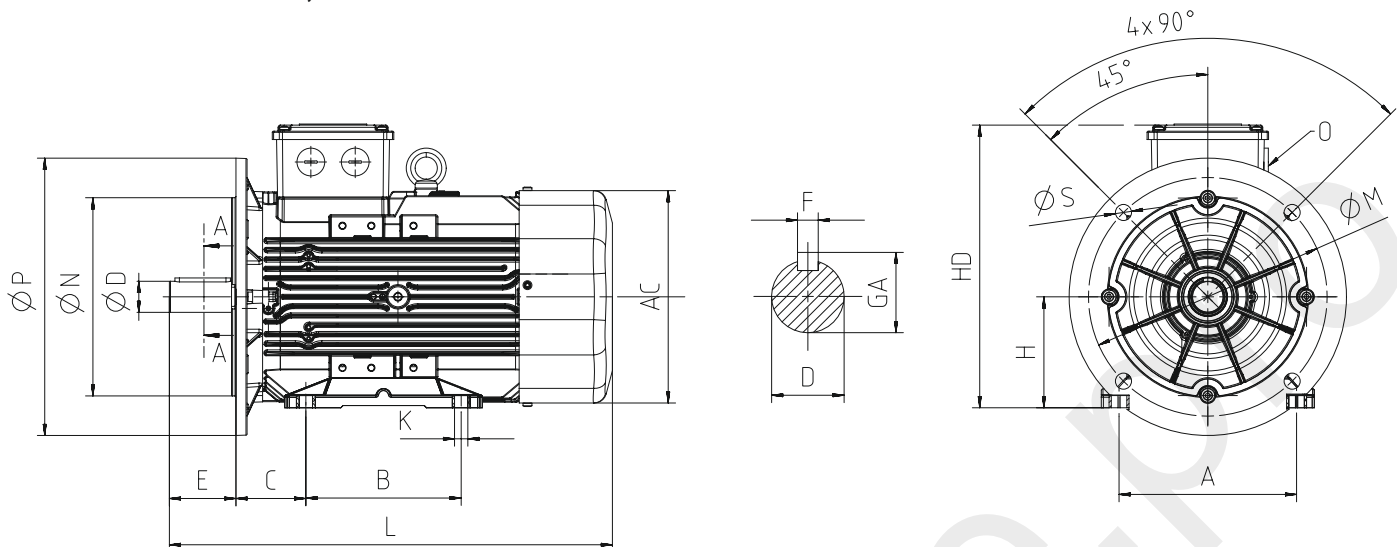

Power (kW)	Number of Poles	Motor Type	Housing Type	Main Dimensions			Foot Mounted Motors					Shaft			Bearing		Seal		Flange (FA) (B5)					
				AC	L	O	B	A	H	HD	K	D ⁽¹⁾	E	GA	F ⁽²⁾	Drive Side	Non drive Side	Drive Side	Non drive Side	P	N ⁽³⁾	M	R	S
1,1	4	Q2H80M4D	Aluminium	158	268	1xM20	100	125	80	216	10,0	19	40	21,5	6	6204-ZZ	6204-ZZ	20*30*7	20*30*7	200	130	165	-	12,0
1,5	2	Q2H80M2D	Aluminium	158	268	1xM20	100	125	80	216	10,0	19	40	21,5	6	6204-ZZ	6204-ZZ	20*30*7	20*30*7	200	130	165	-	12,0
1,5	4	Q2H80M4DE	Aluminium	158	268	1xM20	100	125	80	216	10,0	19	40	21,5	6	6204-ZZ	6204-ZZ	20*30*7	20*30*7	200	130	165	-	12,0
2,2	2	Q2H80M2DE	Aluminium	158	268	1xM20	100	125	80	216	10,0	19	40	21,5	6	6204-ZZ	6204-ZZ	20*30*7	20*30*7	200	130	165	-	12,0
2,2	4	Q2H90L4D	Aluminium	172	344	1xM25	100-125	140	90	223	10,0	24	50	27,0	8	6305-ZZ	6205-ZZ	25*40*7	25*40*7	200	130	165	-	12,0
3,0	2	Q2H90L2D	Aluminium	172	344	1xM25	100-125	140	90	223	10,0	24	50	27,0	8	6305-ZZ	6205-ZZ	25*40*7	25*40*7	200	130	165	-	12,0
3,0	4	Q2H90L4DE	Aluminium	172	379	1xM25	100-125	140	90	223	10,0	24	50	27,0	8	6305-ZZ	6205-ZZ	25*40*7	25*40*7	200	130	165	-	12,0
4,0	2	Q2HS100L2C	Aluminium	172	384	1xM25	140	160	100	233	12,0	28	60	31,0	8	6306-ZZ	6205-ZZ	30*47*7	25*40*7	250	180	215	-	14,5
4,0	4	Q2H100L4D	Aluminium	191	400	1xM25	140	160	100	243	12,0	28	60	31,0	8	6306-ZZ	6205-ZZ	30*47*7	30*47*7	250	180	215	-	14,5
5,5	2	Q2HS112M2C	Aluminium	191	399	1xM25	140	190	112	254	12,0	28	60	31,0	8	6306-ZZ	6205-ZZ	30*47*7	25*40*7	250	180	215	-	14,5
5,5	4	Q2H112M4D	Aluminium	210	421	1xM25	140	190	112	265	12,0	28	60	31,0	8	6306-ZZ	6206-ZZ	30*47*7	30*47*7	250	180	215	-	14,5
7,5	2	Q2HS112M2D	Aluminium	191	421	1xM25	140	190	112	254	12,0	28	60	31,0	8	6306-ZZ	6205-ZZ	30*47*7	25*40*7	250	180	215	-	14,5
11,0	2	Q2H132M2A	Aluminium	260	481	1xM32	140-178	216	132	312	12,0	38	80	41,0	10	6208-ZZ	6208-ZZ	40*62*10	40*62*10	300	230	265	-	14,5
11,0	4	Q2H132M4D	Aluminium	260	481	1xM32	140-178	216	132	312	12,0	38	80	41,0	10	6208-ZZ	6208-ZZ	40*62*10	40*62*10	300	230	265	-	14,5
15,0	2	Q2H132M2B	Aluminium	260	481	1xM32	140-178	216	132	312	12,0	38	80	41,0	10	6208-ZZ	6208-ZZ	40*62*10	40*62*10	300	230	265	-	14,5
15,0	4	Q2H132M4E	Aluminium	260	539	1xM32	140-178	216	132	312	12,0	38	80	41,0	10	6208-ZZ	6208-ZZ	40*62*10	40*62*10	300	230	265	-	14,5
18,5	2	Q2H132M2C	Aluminium	260	539	1xM32	140-178	216	132	312	12,0	38	80	41,0	10	6208-ZZ	6208-ZZ	40*62*10	40*62*10	300	230	265	-	14,5
18,5	4	Q2H160L4B	Aluminium	305	591	1xM32	210-254	254	160	368	14,5	42	110	45,0	12	6309-ZZ	6209-ZZ	45*72*10	45*72*10	350	250	300	-	18,5
22,0	2	Q2H160L2C	Aluminium	305	591	1xM32	210-254	254	160	368	14,5	42	110	45,0	12	6309-ZZ	6209-ZZ	45*72*10	45*72*10	350	250	300	-	18,5
22,0	4	Q2H160L4C	Aluminium	305	591	1xM32	210-254	254	160	368	14,5	42	110	45,0	12	6309-ZZ	6209-ZZ	45*72*10	45*72*10	350	250	300	-	18,5
30,0	2	Q2H180M2B	Aluminium	349	696	1xM40	241-279	279	180	437	14,5	48	110	51,5	14	6310-ZZ	6310-ZZ	50*80*10	50*80*10	350	250	300	-	18,5
30,0	4	Q2H180L4C	Aluminium	349	696	1xM40	241-279	279	180	437	14,5	48	110	51,5	14	6310-ZZ	6310-ZZ	50*80*10	50*80*10	350	250	300	-	18,5
37,0	2	Q2H180M2C	Aluminium	349	696	1xM40	241-279	279	180	437	14,5	48	110	51,5	14	6310-ZZ	6310-ZZ	50*80*10	50*80*10	350	250	300	-	18,5
37,0	4	Q2H200L4D	Aluminium	349	759	1xM50	267-305	318	200	455	18,5	55	110	59,0	16	6312-ZZ	6310-ZZ	60*90*10	60*90*10	400	300	350	-	18,5
45,0	2	Q2H200L2D	Aluminium	349	759	1xM50	267-305	318	200	455	18,5	55	110	59,0	16	6312-ZZ	6310-ZZ	60*90*10	60*90*10	400	300	350	-	18,5
55,0	2	Q2E225M2C	Aluminium	456	735	1xM50	286-311	356	225	485	18,5	55	110	59,0	16	6313-ZZ	6313-ZZ	65*100*13	65*100*13	450	350	400	-	18,5
75,0	2	Q2EP250M2C	Cast Iron	489	893	1xM50	349	406	250	616	24,0	60	140	69,0	18	6316-Z	6316-Z	80*100*10	80*100*10	550	450	500	-	18,5
75,0	4	Q2EP250M4E	Cast Iron	489	893	1xM50	349	406	250	616	24,0	65	140	69,0	18	6316-Z	6316-Z	80*100*10	80*100*10	550	450	500	-	18,5
110,0	2	Q2EP280M2D	Cast Iron	489	1025	1xM50	419	457	280	647	24,0	65	140	69,0	18	6316-Z	6316-Z	80*100*10	80*100*10	550	450	500	-	18,5
110,0	4	Q2EP280M4E	Cast Iron	489	1025	1xM50	419	457	280	647	24,0	75	140	79,5	20	6316-Z	6316-Z	80*100*10	80*100*10	550	450	500	-	18,5

(1) Tolerance DIN EN 50347 "j6" up to 28mm, "k6" above 28mm

(2) According to DIN 6885

(3) Tolerance DIN EN 50347 "j6"

DIMENSION - B14a, B34a

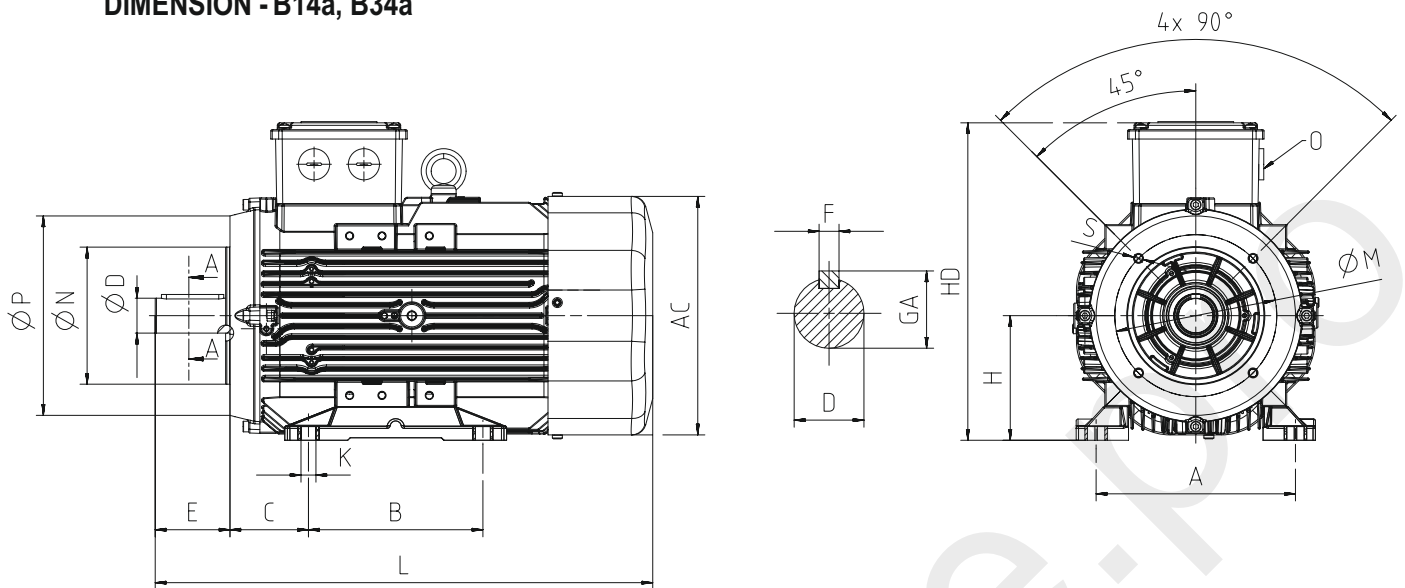

Power (kW)	Number of Poles	Motor Type	Housing Type	Main Dimensions			Foot Mounted Motors					Shaft				Bearing		Seal		Flange (FA) (B5)				
				AC	L	O	B	A	H	HD	K	D ⁽¹⁾	E	GA	F ⁽²⁾	Drive Side	Non drive Side	Drive Side	Non drive Side	P	N ⁽³⁾	M	R	S
1,1	4	Q2H80M4D	Aluminium	158	268	1xM20	100	125	80	216	10	19	40	21,5	6	6204-ZZ	6204-ZZ	20*30*7	20*30*7	120	80	100	-	M6
1,5	2	Q2H80M2D	Aluminium	158	268	1xM20	100	125	80	216	10	19	40	21,5	6	6204-ZZ	6204-ZZ	20*30*7	20*30*7	120	80	100	-	M6
1,5	4	Q2H80M4DE	Aluminium	158	268	1xM20	100	125	80	216	10	19	40	21,5	6	6204-ZZ	6204-ZZ	20*30*7	20*30*7	120	80	100	-	M6
2,2	2	Q2H80M2DE	Aluminium	158	268	1xM20	100	125	80	216	10	19	40	21,5	6	6204-ZZ	6204-ZZ	20*30*7	20*30*7	120	80	100	-	M6
2,2	4	Q2H90L4D	Aluminium	172	344	1xM25	100-125	140	90	223	10	24	50	27,0	8	6305-ZZ	6205-ZZ	25*40*7	25*40*7	140	95	115	-	M8
3,0	2	Q2H90L2D	Aluminium	172	344	1xM25	100-125	140	90	223	10	24	50	27,0	8	6305-ZZ	6205-ZZ	25*40*7	25*40*7	140	95	115	-	M8
3,0	4	Q2H90L4DE	Aluminium	172	379	1xM25	100-125	140	90	223	10	24	50	27,0	8	6305-ZZ	6205-ZZ	25*40*7	25*40*7	140	95	115	-	M8
4,0	2	Q2HS100L2C	Aluminium	172	384	1xM25	140	160	100	233	12	28	60	31,0	8	6306-ZZ	6205-ZZ	30*47*7	25*40*7	160	110	130	-	M8
4,0	4	Q2H100L4D	Aluminium	191	400	1xM25	140	160	100	243	12	28	60	31,0	8	6306-ZZ	6205-ZZ	30*47*7	30*47*7	160	110	130	-	M8
5,5	2	Q2HS112M2C	Aluminium	191	399	1xM25	140	190	112	254	12	28	60	31,0	8	6306-ZZ	6205-ZZ	30*47*7	25*40*7	160	110	130	-	M8
5,5	4	Q2H112M4D	Aluminium	210	421	1xM25	140	190	112	265	12	28	60	31,0	8	6306-ZZ	6206-ZZ	30*47*7	30*47*7	160	110	130	-	M8
7,5	2	Q2HS112M2D	Aluminium	191	421	1xM25	140	190	112	254	12	28	60	31,0	8	6306-ZZ	6205-ZZ	30*47*7	25*40*7	160	110	130	-	M8
11,0	2	Q2H132M2A	Aluminium	260	481	1xM32	140-178	216	132	312	12	38	80	41,0	10	6208-ZZ	6208-ZZ	40*62*10	40*62*10	200	130	165	-	M10
11,0	4	Q2H132M4D	Aluminium	260	539	1xM32	140-178	216	132	312	12	38	80	41,0	10	6208-ZZ	6208-ZZ	40*62*10	40*62*10	200	130	165	-	M10
15,0	2	Q2H132M2B	Aluminium	260	539	1xM32	140-178	216	132	312	12	38	80	41,0	10	6208-ZZ	6208-ZZ	40*62*10	40*62*10	200	130	165	-	M10
15,0	4	Q2H132M4E	Aluminium	260	539	1xM32	140-178	216	132	312	12	38	80	41,0	10	6208-ZZ	6208-ZZ	40*62*10	40*62*10	200	130	165	-	M10
18,5	2	Q2H132M2C	Aluminium	260	539	1xM32	140-178	216	132	312	12	38	80	41,0	10	6208-ZZ	6208-ZZ	40*62*10	40*62*10	200	130	165	-	M10

(1) Tolerance DIN EN 50347 "j6" up to 28mm, "k6" above 28mm

(2) According to DIN 6885

(3) Tolerance DIN EN 50347 "j6"

DIMENSION - B14b, B34b

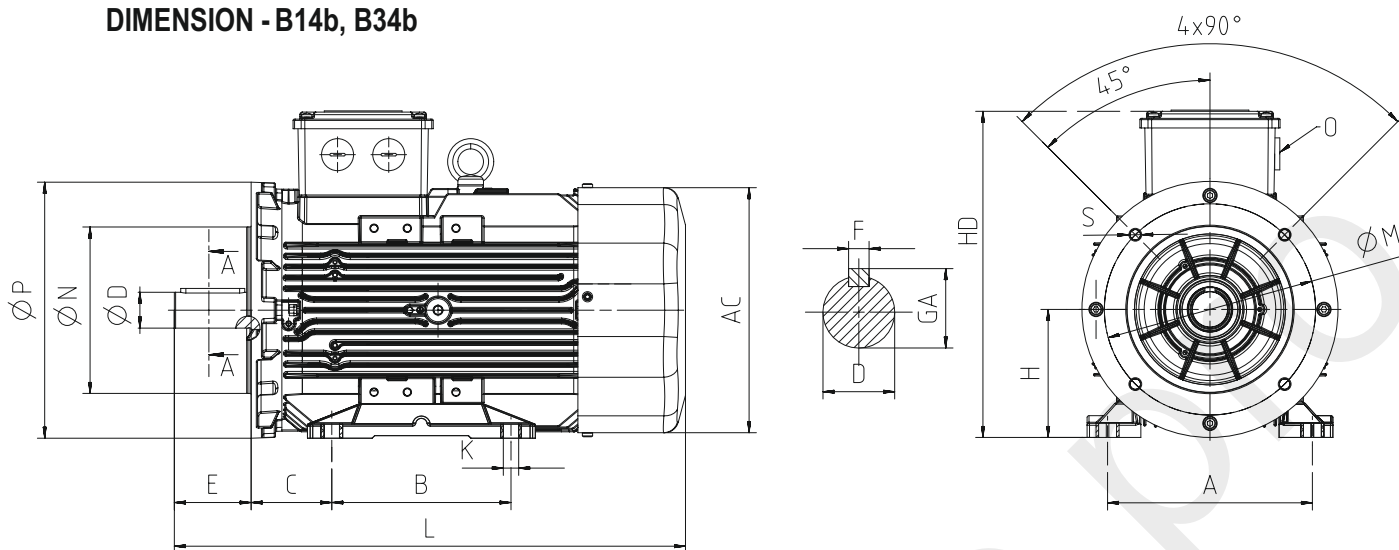

Power (kW)	Number of Poles	Motor Type	Housing Type	Main Dimensions			Foot Mounted Motors					Shaft			Bearing		Seal		Flange (FA) (B5)					
				AC	L	O	B	A	H	HD	K	D ⁽¹⁾	E	GA	F ⁽²⁾	Drive Side	Non drive Side	Drive Side	Non drive Side	P	N ⁽³⁾	M	R	S
1,1	4	Q2H80M4D	Aluminium	158	268	1xM20	100	125	80	216	10	19	40	21,5	6	6204-ZZ	6204-ZZ	20*30*7	20*30*7	160	110	130	-	M8
1,5	2	Q2H80M2D	Aluminium	158	268	1xM20	100	125	80	216	10	19	40	21,5	6	6204-ZZ	6204-ZZ	20*30*7	20*30*7	160	110	130	-	M8
1,5	4	Q2H80M4DE	Aluminium	158	268	1xM20	100	125	80	216	10	19	40	21,5	6	6204-ZZ	6204-ZZ	20*30*7	20*30*7	160	110	130	-	M8
2,2	2	Q2H80M2DE	Aluminium	158	268	1xM20	100	125	80	216	10	19	40	21,5	6	6204-ZZ	6204-ZZ	20*30*7	20*30*7	160	110	130	-	M8
2,2	4	Q2H90L4D	Aluminium	172	344	1xM25	100-125	140	90	223	10	24	50	27,0	8	6305-ZZ	6205-ZZ	25*40*7	25*40*7	160	110	130	-	M8
3,0	2	Q2H90L2D	Aluminium	172	344	1xM25	100-125	140	90	223	10	24	50	27,0	8	6305-ZZ	6205-ZZ	25*40*7	25*40*7	160	110	130	-	M8
3,0	4	Q2H90L4DE	Aluminium	172	379	1xM25	100-125	140	90	223	10	24	50	27,0	8	6305-ZZ	6205-ZZ	25*40*7	25*40*7	160	110	130	-	M8
4,0	2	Q2HS100L2C	Aluminium	172	384	1xM25	140	160	100	233	12	28	60	31,0	8	6306-ZZ	6205-ZZ	30*47*7	25*40*7	200	130	165	-	M10
4,0	4	Q2H100L4D	Aluminium	191	400	1xM25	140	160	100	243	12	28	60	31,0	8	6306-ZZ	6205-ZZ	30*47*7	30*47*7	200	130	165	-	M10
5,5	2	Q2HS112M2C	Aluminium	191	399	1xM25	140	190	112	254	12	28	60	31,0	8	6306-ZZ	6205-ZZ	30*47*7	25*40*7	200	130	165	-	M10
5,5	4	Q2H112M4D	Aluminium	210	421	1xM25	140	190	112	265	12	28	60	31,0	8	6306-ZZ	6206-ZZ	30*47*7	30*47*7	200	130	165	-	M10
7,5	2	Q2HS112M2D	Aluminium	191	421	1xM25	140	190	112	254	12	28	60	31,0	8	6306-ZZ	6205-ZZ	30*47*7	25*40*7	200	130	165	-	M10
11,0	2	Q2H132M2A	Aluminium	260	481	1xM32	140-178	216	132	312	12	38	80	41,0	10	6208-ZZ	6208-ZZ	40*62*10	40*62*10	250	180	215	-	M12
11,0	4	Q2H132M4D	Aluminium	260	539	1xM32	140-178	216	132	312	12	38	80	41,0	10	6208-ZZ	6208-ZZ	40*62*10	40*62*10	250	180	215	-	M12
15,0	2	Q2H132M2B	Aluminium	260	539	1xM32	140-178	216	132	312	12	38	80	41,0	10	6208-ZZ	6208-ZZ	40*62*10	40*62*10	250	180	215	-	M12
15,0	4	Q2H132M4E	Aluminium	260	539	1xM32	140-178	216	132	312	12	38	80	41,0	10	6208-ZZ	6208-ZZ	40*62*10	40*62*10	250	180	215	-	M12
18,5	2	Q2H132M2C	Aluminium	260	539	1xM32	140-178	216	132	312	12	38	80	41,0	10	6208-ZZ	6208-ZZ	40*62*10	40*62*10	250	180	215	-	M12

(1) Tolerance DIN EN 50347 "j6" up to 28mm, "k6" above 28mm

(2) According to DIN 6885

(3) Tolerance DIN EN 50347 "j6"

DE ERSATZTEILLISTE FÜR MOTOR

EN MOTOR PART LIST

IT ELENCO PARTI MOTORE

FR LISTE DES PIÈCES DU MOTEUR

ES LISTA DE PIEZAS DEL MOTOR

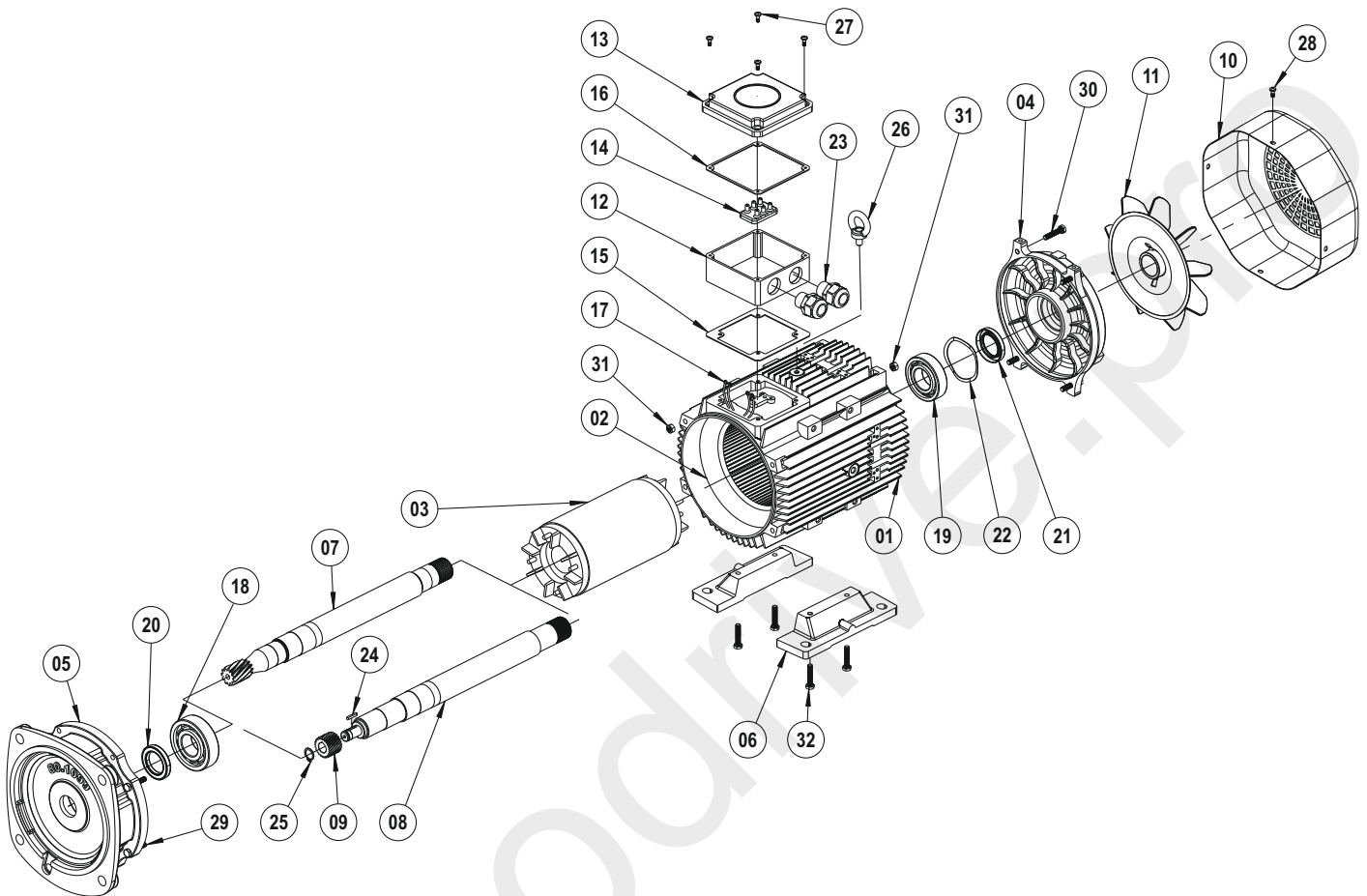

01 Gehäuse	Housing	Involucro	corps	cuerpo
02 gewickelter Stator	Wound Stator	Statore	Stator	Stator
03 Rotor	Rotor	Rotore	Rotor	Rotor
04 B-Lagerschild	Nondrive - Endshield	Portellone motore	Portellone motore	Tapa trasera del motor
05 Motor-Anschlussflansch	Motor Connection Flange	Flangia di collegamento del motore	Bride de raccordement moteur	Brida de conexión del motor
06 Fuß	Foot	Piede	Pied	Pie
07 Antriebswelle (verzahnt)	Drive Shaft (Gearcut)	Albero motore (monolithic)	Arbre moteur (monolithique)	eje motor (monolítico)
08 Antriebswelle (glatt)	Drive Shaft (Plain)	Albero motore (dritto)	Arbre moteur (lisse)	eje motor (suave)
09 Antriebsritzel	Z1 Gear	Ingresso Pignone	Pignon d'entrée	Piñón de entrada
10 Lüfterhaube	Fan Cover	Copriventola	Couvercle	versión de fan
11 Lüfter	Fan	Fan	Fan	Fan
12 Klemmkasten	Terminal Box	Morsettiera	Boîte à bornes	Caja de terminales
13 Klemmkastendeckel	Terminal Box Cover	Coperchio della morsettiera	Couvercle de la boîte à bornes	Cubierta de la caja de terminales
14 Anschlussplatte	Terminal Plate	Piastra terminale	Plaque à bornes	Placa de terminales
15 Klemmkastendichtung unten	Terminal Gasket Down	Sigillo terminale - giù	Joint de borne - bas	Junta de terminal - inferior
16 Klemmkastendichtung oben	Terminal Gasket Up	Sigillo terminale - su	Joint de borne - haut	Junta de terminal - superior
17 Kabelbaum	Cables	Cavi di piombo	Câbles de plomb	Cables de plomo
18 Kugellager (Antriebsseite)	Bal Bearing (Drive-Side)	Cuscinetto (fronte)	Roulement (avant)	Cojinete (delantero)
19 Kugellager (Nicht-Antriebsseite)	Bal Bearing (Non-Drive-Side)	Cuscinetto (retro)	Roulement (arrière)	Cojinete (trasero)
20 Dichtungsring (Vorne)	Seal Ring (Front)	Anello di tenuta (anteriore)	Bague d'étanchéité (avant)	Anillo de sellado (delantero)
21 Dichtungsring (Hinten)	Seal Ring (Back)	anello di tenuta (posteriore)	Bague d'étanchéité (arrière)	Anillo de sellado (trasero)
22 Stützscheibe	Bearing Shim	molla del cuscinetto	ressort de roulement	resorte rodante
23 Gewindemuffe	Conduit	presa filettata	douille filetée	casquillo roscado
24 Passfeder	Key	Chiavetta	Clavette	Clave
25 Sicherungsring DIN 471	Circlip DIN 471	Anello di sicurezza DIN 471	Circlip DIN 471	Anillo de seguridad DIN 471
26 Augenschraube	Eye Bolt	vite ad anello	anneau de levage	Perno de anilla
27 Kreuzschlitzschraube	Pan Head Screws	Viti a Stella	Vis étoile	tornillo de estrella
28 Kreuzschlitzschraube	Pan Head Screws	Viti a Stella	Vis étoile	tornillo de estrella
29 Schraube DIN 933	Bolt	Bullone	Boulonner	Atornillar
30 Schraube DIN 933	Bolt	Bullone	Boulonner	Atornillar
31 Schraubenmutter	Nut	Dado	Ecrou	Tuerca
32 Schraube DIN 933	Bolt	Bullone	Boulonner	Atornillar

DE ERSATZTEILLISTE FÜR MOTOR MIT BREMSE

EN BRAKE MOTOR PART LIST

IT ELENCO DELLE PARTI DEL MOTORE DEL FRENO

FR LISTE DES PIÈCES DU MOTEUR DE FREIN

ES LISTA DE PIEZAS DEL MOTOR DE FRENO

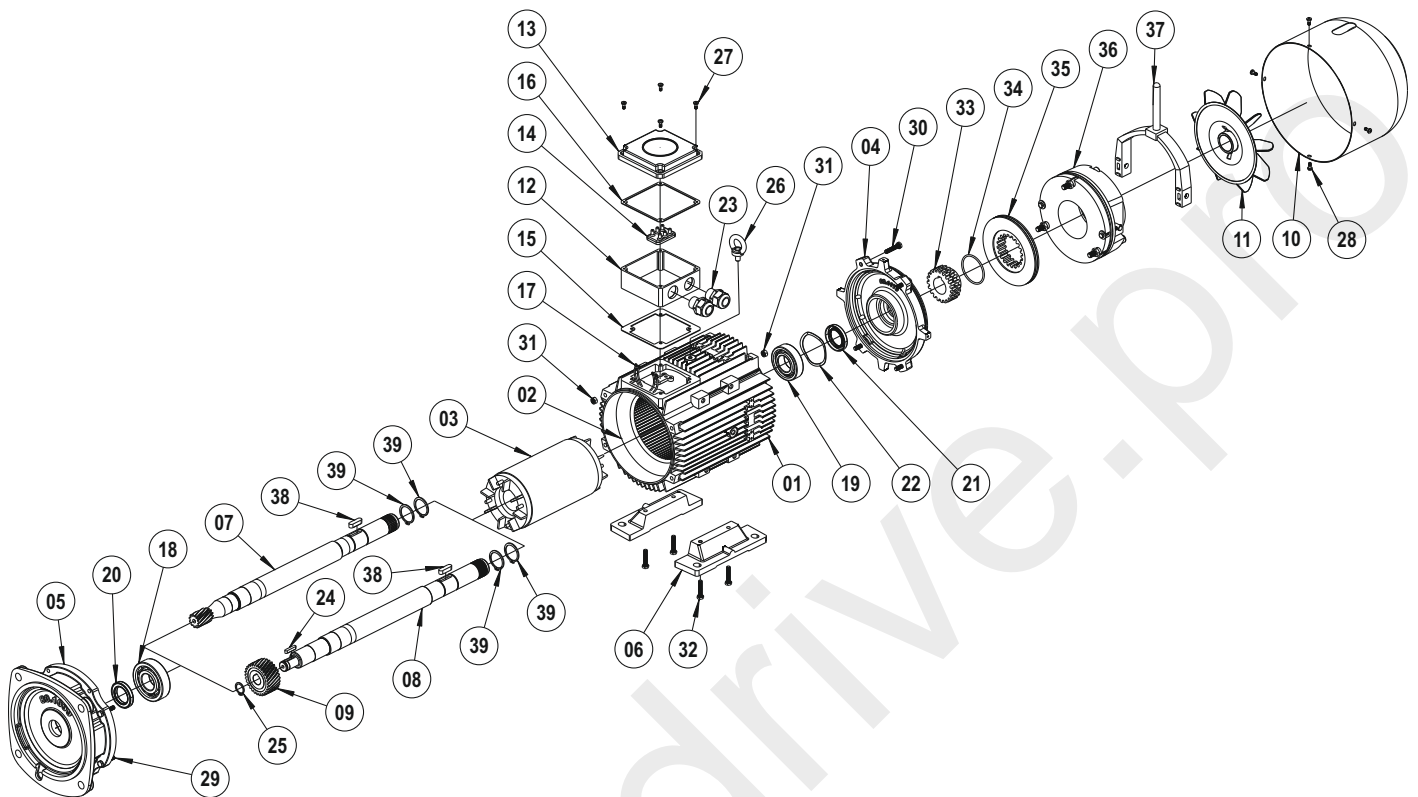

01 Gehäuse	Housing	Involucro	corps	cuerpo
02 gewickelter Stator	Wound Stator	Statore	Stator	Stator
03 Rotor	Rotor	Rotore	Rotor	Rotor
04 Bremsflansch	Brake Connection Flange	Flangia di collegamento del freno	Bride de connexion de frein	Brida de conexión de freno
05 Moter-Anschlussflansch	Motor Connection Flange	Flangia di collegamento del motore	Bride de raccordement moteur	Brida de conexión del motor
06 Fuß	Foot	Piede	Pied	Pie
07 Antriebswelle (verzahnt)	Drive Shaft (Gearcut)	Albero motore (monolithic)	Arbre moteur (monolithique)	eje motor (monolítico)
08 Antriebswelle (glatt)	Drive Shaft (Plain)	Albero motore (dritto)	Arbre moteur (lisse)	eje motor (suave)
09 Antriebsritzel	Z1 Gear	Ingresso Pignone	Pignon d'entrée	Piñón de entrada
10 Lüfterhaube	Fan Cover	Copriventola	Couvercle	versión de fan
11 Lüfter	Fan	Fan	Fan	Fan
12 Klemmkasten	Terminal Box	Morsettiera	Boîte à bornes	Caja de terminales
13 Klemmkastendeckel	Terminal Box Cover	Coperchio della morsettiera	Couvercle de la boîte à bornes	Cubierta de la caja de terminales
14 Anschlussplatte	Terminal Plate	Piastra terminale	Plaque à bornes	Placa de terminales
15 Klemmkastendichtung unten	Terminal Gasket Down	Sigillo terminale - giù	Joint de borne - bas	Junta de terminal - inferior
16 Klemmkastendichtung oben	Terminal Gasket Up	Sigillo terminale - su	Joint de borne - haut	Junta de terminal - superior
17 Kabelbaum	Lead Cables	Cavi di piombo	Câbles de plomb	Cables de plomo
18 Kugellager (Antriebsseite)	Bal Bearing (Drive-Side)	Cuscinetto (fronte)	Roulement (avant)	Cojinete (delantero)
19 Kugellager (Nicht-Antriebsseite)	Bal Bearing (Non-Drive-Side)	Cuscinetto (retro)	Roulement (arrière)	Cojinete (trasero)
20 Dichtungsring (Vorne)	Seal Ring (Front)	Anello di tenuta (anteriore)	Bague d'étanchéité (avant)	Anillo de sellado (delantero)
21 Dichtungsring (Hinten)	Seal Ring (Back)	anello di tenuta (posteriore)	Bague d'étanchéité (arrière)	Anillo de sellado (trasero)
22 Stützscheibe	Bearing Shim	molla del cuscinetto	ressort de roulement	resorte rodante
23 Gewindemuffe	Conduit	presa filettata	douille fileté	casquillo roscado
24 Passfeder	Key	Chiavetta	Clavette	Clave
25 Sicherungsring DIN 471	Circilip DIN 471	Anello di sicurezza DIN 471	Circlip DIN 471	Anillo de seguridad DIN 471
26 Augenschraube	Eye Bolt	vite ad anello	anneau de levage	Perno de anilla
27 Kreuzschlitzschraube	Pan Head Screws	Viti a Stella	Vis étoile	tornillo de estrella
28 Kreuzschlitzschraube	Pan Head Screws	Viti a Stella	Vis étoile	tornillo de estrella
29 Schraube DIN 933	Bolt	Bullone	Boulonner	Atornillar
30 Schraube DIN 933	Bolt	Bullone	Boulonner	Atornillar
31 Schraubenmutter	Nut	Dado	Ecrou	Tuerca
32 Schraube DIN 933	Bolt	Bullone	Boulonner	Atornillar
33 Kupplung	Coupling	Accoppiamento	Couplage	Acoplamiento
34 O-Ring	O-Ring	O-Ring	O-Ring	O-Ring
35 Bremsbelag	Brake Lining	Guarnizioni dei freni	Garniture de frein	Romper el forro
36 Bremse	Brake	freno	Frein	Freno
37 Handauslöser	Hand Release	Leva manuale	Levier manuel	Palanca manual
38 Passfeder	Key	Chiavetta	Clavette	Clave
39 Sicherungsring DIN 471	Circilip DIN 471	Anello di sicurezza DIN 471	Circlip DIN 471	Anillo de seguridad DIN 471

DE ERSATZTEILLISTE FÜR MOTOR
MIT B3-B5-B14-FLANSCH

EN B3-B5-B14 FLANGE MOTOR PART LIST

IT B3-B5-B14 ELENCO PARTI
MOTORE FLANGIA

FR LISTE DES PIÈCES DU MOTEUR
À BRIDE B3-B5-B14

ES B3-B5-B14 LISTA DE PIEZAS DEL
MOTOR CON BRIDA

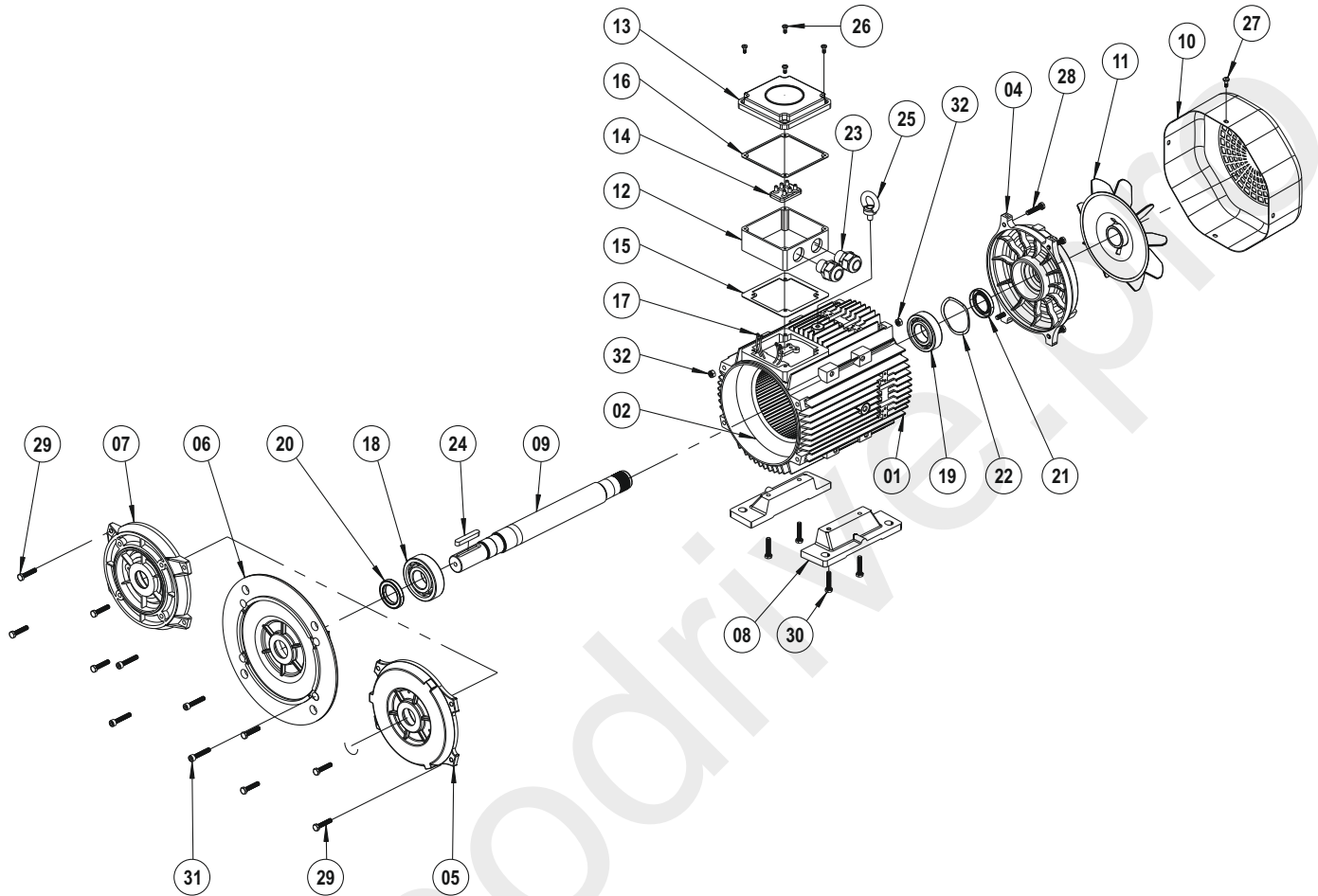

01 Gehäuse	Housing	Involucro	corps	cuerpo
02 gewickelter Stator	Wound Stator	Statore	Stator	Stator
03 Rotor	Rotor	Rotore	Rotor	Rotor
04 B-Lagerschild	Nondrive - Endshield	Portellone motore	Portellone motore	Tapa trasera del motor
05 B3 Flansch	B3 Flange	Flangia B3	Bride B3	Brida B3
06 B5 Flansch	B5 Flange	Flangia B5	Bride B5	Brida B5
07 B14 Flansch	B14 Flange	Flangia B14	Bride B14	Brida B14
08 Fuß	Foot	Piede	Pied	Pie
09 Antriebswelle (standart)	Drive Shaft (standard)	Albero motore (standard)	Arbre moteur (la norme)	eje motor (estándar)
10 Lüfterhaube	Fan Cover	Copriventola	Couvercle	versión de fan
11 Lüfter	Fan	Fan	Fan	Fan
12 Klemmkasten	Terminal Box	Morsettiera	Boîte à bornes	Caja de terminales
13 Klemmkastendeckel	Terminal Box Cover	Coperchio della morsettiera	Couvercle de la boîte à bornes	Cubierta de la caja de terminales
14 Anschlussplatte	Terminal Plate	Piastra terminale	Plaque à bornes	Placa de terminales
15 Klemmkastendichtung unten	Terminal Gasket Down	Sigillo terminale - giù	Joint de borne - bas	Junta de terminal - inferior
16 Klemmkastendichtung oben	Terminal Gasket Up	Sigillo terminale - su	Joint de borne - haut	Junta de terminal - superior
17 Kabelbaum	Lead Cables	Cavi di piombo	Câbles de plomb	Cables de plomo
18 Kugellager (Antriebsseite)	Bal Bearing (Drive-Side)	Cuscinetto (fronte)	Roulement (avant)	Cojinete (delantero)
19 Kugellager (Nicht-Antriebsseite)	Bal Bearing (Non-Drive-Side)	Cuscinetto (retro)	Roulement (arrière)	Cojinete (trasero)
20 Dichtungsring (Vorne)	Seal Ring (Front)	Anello di tenuta (anteriore)	Bague d'étanchéité (avant)	Anillo de sellado (delantero)
21 Dichtungsring (Hinten)	Seal Ring (Back)	anello di tenuta (posteriore)	Bague d'étanchéité (arrière)	Anillo de sellado (trasero)
22 Stützscheibe	Bearing Shim	molla del cuscinetto	ressort de roulement	resorte rodante
23 Gewindemuffe	Conduit	presa filettata	douille fileté	casquillo roscado
24 Passfeder	Key	Chiavetta	Clavette	Clave
25 Augenschraube	Eye Bolt	vite ad anello	anneau de levage	Perno de anilla
26 Kreuzschlitzschraube	Pan Head Screws	Viti a Stella	Vis étoile	tornillo de estrella
27 Kreuzschlitzschraube	Pan Head Screws	Viti a Stella	Vis étoile	tornillo de estrella
28 Schraube DIN 933	Bolt	Bullone	Boulonner	Atornillar
29 Schraube DIN 933	Bolt	Bullone	Boulonner	Atornillar
30 Schraube DIN 933	Bolt	Bullone	Boulonner	Atornillar
31 Schraube DIN 912	Bolt	Bullone	Boulonner	Atornillar
32 Schraubenmutter	Nut	Dado	Ecrou	Tuerca

DE ERSATZTEILLISTE FÜR MOTOR MIT BREMSE UND B3-B5-B14-FLANSCH

EN BRAKE B3-B5-B14 FLANGE MOTOR PART LIST

IT FRENO B3-B5-B14 ELENCO PARTI MOTORE FLANGIA

FR FREIN B3-B5-B14 BRIDE MOTEUR LISTE DES PIÈCES

ES FRENO B3-B5-B14 BRIDA LISTA DE PIEZAS DEL MOTOR

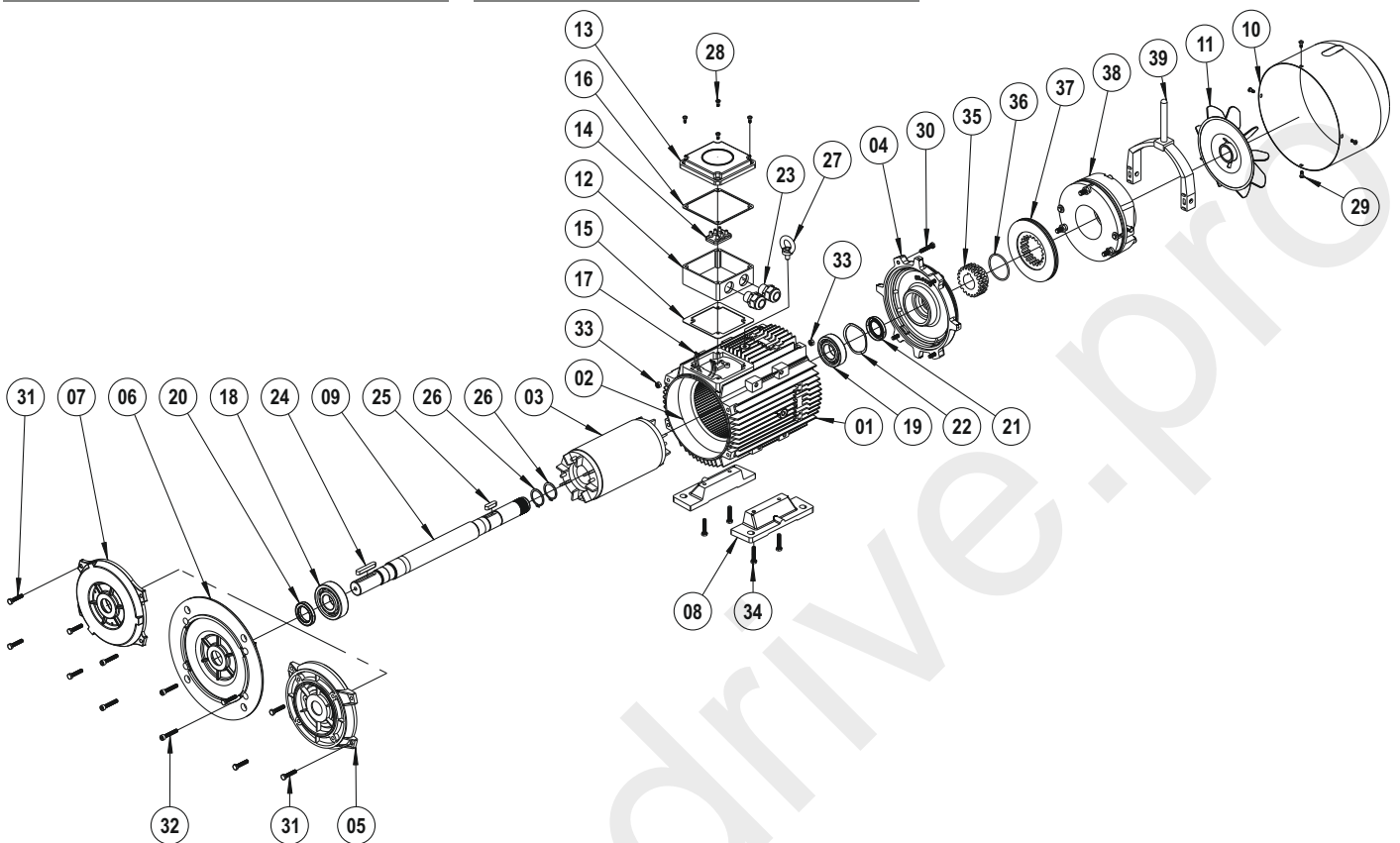

01 Gehäuse	Housing	Invólucro	corps	cuerpo
02 gewickelter Stator	Wound Stator	Statore	Stator	Stator
03 Rotor	Rotor	Rotore	Rotor	Rotor
04 Bremsflansch	Brake Connection Flange	Flangia di collegamento del freno	Bride de connexion de frein	Brida de conexión de freno
05 B3 Flansch	B3 Flange	Flangia B3	Bride B3	Brida B3
06 B5 Flansch	B5 Flange	Flangia B5	Bride B5	Brida B5
07 B14 Flansch	B14 Flange	Flangia B14	Bride B14	Brida B14
08 Fuß	Foot	Piede	Pied	Pie
09 Antriebswelle (standard)	Drive Shaft (standard)	Albero motore (standard)	Arbre moteur (la norme)	eje motor (estándar)
10 Lüfterhaube	Fan Cover	Copriventola	Couvercle	versión de fan
11 Lüfter	Fan	Fan	Fan	Fan
12 Klemmkasten	Terminal Box	Morsettiera	Boîte à bornes	Caja de terminales
13 Klemmkastendeckel	Terminal Box Cover	Coperchio della morsettiera	Couvercle de la boîte à bornes	Cubierta de la caja de terminales
14 Anschlussplatte	Terminal Plate	Piastra terminale	Plaque à bornes	Placa de terminales
15 Klemmkastendichtung unten	Terminal Gasket Down	Sigillo terminale - giù	Joint de borne - bas	Junta de terminal - inferior
16 Klemmkastendichtung oben	Terminal Gasket Up	Sigillo terminale - su	Joint de borne - haut	Junta de terminal - superior
17 Kabelbaum	Lead Cables	Cavi di piombo	Câbles de plomb	Cables de plomo
18 Kugellager (Antriebsseite)	Bal Bearing (Drive-Side)	Cuscinetto (fronte)	Roulement (avant)	Cojinete (delantero)
19 Kugellager (Nicht-Antriebsseite)	Bal Bearing (Non-Drive-Side)	Cuscinetto (retro)	Roulement (arrière)	Cojinete (trasero)
20 Dichtungsring (Vorne)	Seal Ring (Front)	Anello di tenuta (anteriore)	Bague d'étanchéité (avant)	Anillo de sellado (delantero)
21 Dichtungsring (Hinten)	Seal Ring (Back)	anello di tenuta (posteriore)	Bague d'étanchéité (arrière)	Anillo de sellado (trasero)
22 Stützscheibe	Bearing Shim	molla del cuscinetto	ressort de roulement	resorte rodante
23 Gewindemuffe	Conduit	presa filettata	douille fileté	casquillo roscado
24 Passfeder	Key	Chiavetta	Clavette	Clave
25 Passfeder	Key	Chiavetta	Clavette	Clave
26 Sicherungsring DIN 471	Circlip DIN 471	Anello di sicurezza DIN 471	Circlip DIN 471	Anillo de seguridad DIN 471
27 Augenschraube	Eye Bolt	vite ad anello	anneau de levage	Perno de anilla
28 Kreuzschlitzschraube	Pan Head Screws	Viti a Stella	Vis étoile	tornillo de estrella
29 Kreuzschlitzschraube	Pan Head Screws	Viti a Stella	Vis étoile	tornillo de estrella
30 Schraube DIN 933	Bolt	Bullone	Boulonner	Atornillar
31 Schraube DIN 933	Bolt	Bullone	Boulonner	Atornillar
32 Schraube DIN 912	Bolt	Bullone	Boulonner	Atornillar
33 Schraubenmutter	Nut	Dado	Ecrou	Tuerca
34 Schraube DIN 933	Bolt	Bullone	Boulonner	Atornillar
35 Kupplung	Coupling	Accoppiamento	Couplage	Acoplamiento
36 O-Ring	O-Ring	O-Ring	O-Ring	O-Ring
37 Bremsbelag	Brake Lining	Guarnizioni dei freni	Garniture de frein	Romper el forro
38 Bremse	Brake	freno	Frein	Freno
39 Handauslöser	Hand Release	Leva manuale	Levier manuel	Palanca manual

DE BREMSE-TEILELISTE

EN BRAKE PART LIST

IT ELENCO DELLE PARTI DEL FRENO

FR LISTE DES PIÈCES DE FREIN

ES LISTA DE PIEZAS DE FRENO

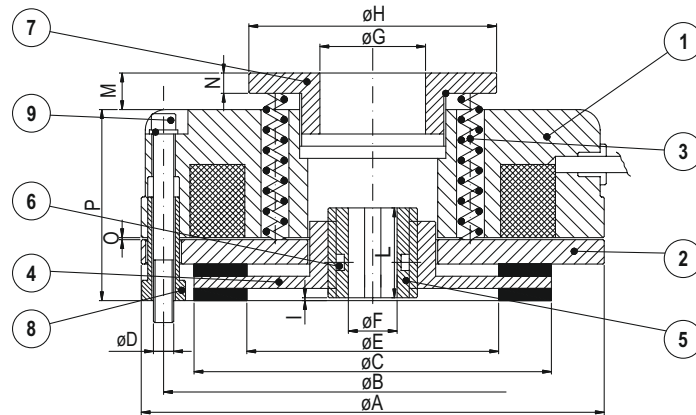

- | | | | | |
|---------------------|----------------|-----------------------|--------------------|-----------------------|
| 1 Elektromagnet | Electromagnet | Elettromagnete | Électro-aimant | Electroimán |
| 2 Ankerplatte | Armature plate | Piastra dell'armatura | Plaque d'induit | Placa de armadura |
| 3 Bremsfeder | Torque springs | Molle di coppia | Ressorts de couple | Muelles de torsión |
| 4 Scheibe | Disc | Disco | Disque | Disco |
| 5 Nabe | Splined hub | Mozzo scanalato | Moyeu cannelé | cubo estriado |
| 6 O-Ring | O-ring | O-ring | O-ring | O-ring |
| 7 Einstellring | Adjuster rings | Anelli di regolazione | Anneaux de réglage | Anillos de ajuste |
| 8 Einstellschraube | Adjuster nuts | Dadi di regolazione | Écrous de réglage | Tuercas de ajuste |
| 9 Feststellschraube | Fixing screws | Viti di fissaggio | Vis de fixation | Tornillos de fijación |

Typ / Type / Tipo / Type / Tipo Bremsmodell / Brake Model / Modello di freno / Modèle de frein / Modelo de freno	K1	K2	K3	K4	K5	K6	K7	K7/D	K8	K8/D	K9	K9/D	K9/T
Statisches Bremsmoment / Static Braking Torque / Coppia frenante statica / Couple de freinage statique / Par de frenado estático (Nm)	5	12	16	20	40	60	90	180	200	400	300	600	900
Höchstgeschwindigkeit des Motors / Max Speed of the motor / Velocità massima del motore / Vitesse max. du moteur / Velocidad máxima del motor (rpm)	3000	3000	3000	3000	3000	3000	3000	3000	1500	1500	1500	1500	1500
Eingangleistung / Input Power / Potenza di ingresso / La puissance d'entrée / Potencia de entrada (W)	15	20	25	30	45	50	55	55	60	60	65	65	65
Maximale lautheit / Max noisiness / Rumorosità massima / Bruit maximum / Máximo ruido (≤dB-A)	68	69	68	69	70	70	70	70	70	69	69	69	70
Gewicht / Weight / peso / poids / peso (Kg.)	1,1	1,85	2,55	2,84	4,8	7	12	15	14,3	18	23	28	34
A	84	104	114	124	148	159	189	189	218	218	248	248	248
B	72	90	103	112	132	145	170	170	196	196	230	230	230
C	61	77	88	98	119	128	151	151	176	176	204	204	204
D	3xM4	3xM5	3xM5	3xM6	3xM6	3xM8	3xM8	3xM8	6xM10	6xM10	6xM10	6xM10	9xM10
Bohrungstoleranz bis Größe K3 H7, andere + 0,01/-0,01 Tolerance hole till size K3 H7, others + 0,01/-0,01 Tolleranza foro fino alla misura K3 H7, altri + 0,01/-0,01 Tolérance trou jusqu'à la taille K3 H7, autres + 0,01/-0,01 Tolerancia agujero hasta tamaño K3 H7, otros + 0,01/-0,01	E	35	44	62	69	79	80	90	90	103	103	132	132
F	10-11 12	11-14 15	11-15	14-25	24-25 28	25-30 34	25-30 34	25 H40 34 H60	24-34	34 H60 48	44-45 48	44-45 48	44-45 48-50
G	20	26	26	42	60	60	60	60	60	60	60	60	60
H	50	61	61	79	104	104	104	104	104	104	104	104	104
I	1,5	1,5	1,5	1,5	1,5	1,5	1,5	1,5	1,5	1,5	1,5	1,5	1,5
L	18	20	20	20	25	30	30	60	40	60	40	60	80
M (max)	9	9	9	9,5	18	16	14	14	18	18	18	18	18
N	4	4	4	5,5	8	8	8	8	8	8	8	8	8
O	0,2	0,2	0,2	0,2	0,3	0,3	0,3	0,3	0,3	0,4	0,4	0,4	0,4+0,5
P	38,5	41,5	47	46,5	64	69,5	79	101,5	78	98	80	105	130

Notizen : Bevor die Bremse eingefahren ist, kann das statische Bremsmoment um etwa ± 20 % vom Tabellenwert abweichen.
Note : The brake before running in, the static braking torque value could change by +20% from the reported value.
Nota : Il freno prima del rodaggio, il valore della coppia frenante statica potrebbe variare del +20% dal valore riportato.
Nota : Le frein avant rodage, la valeur du couple de freinage statique peut varier de +20% par rapport à la valeur reportée.
Nota : El valor del par de frenado estático antes de la puesta en marcha del freno podría cambiar en un +20 % con respecto al valor informado.



techno@drive.pro

techno4drive.pro



• In der Schlinge 6, D-59227 Ahlen / GERMANY
• T: +49 (0) 2382-855 7010 • F: +49 (0) 2382-855 7015
• info@nrwdrivetechologies.com • www.nrwdrivetechologies.com

Doc. No: PG.KT.AG.007_00
Rev. / Publication Date: 08.2024