



# MOTORS





## ELECTRIC MOTORS



## INTRODUCTION

CHT series motors have been produced to be mounted on gearboxes and therefore they have mechanical and electrical characteristics particularly right for this use. All our motors are IP55, insulation class F with phase separator to be used with frequency variators, in this condition they can be provided complete with forced ventilation. The motors like the gearboxes are painted with RAL 9022 grey colour epoxy powder.



## TECHNICAL CHARACTERISTICS

- **Cage rotor motors, locked with outside surface ventilation.**
- **Project, construction and test in compliance with CEI2-3, international norms IEC34-1 and principal foreign/international standard.**
- **Power-sizes in specification with IEC 72, national norms UNEL-MEC.**
- **Insulation: class F**
- **Protection: class IP55**
- **Rated power delivered on continuous: S1**
- **European directive ROHS 2002/95/CE**
- **Phase separator**
- **Volt 400/690 standard from 160 up to 355 on request for other sizes**



## FUNCTION WITH A FREQUENCY OF 60

The CHT line motors can function with a frequency of 60 Hz. with differences in performances and electrical sizes as described on the table.

PLATE VOLTAGE 50 Hz	PLATE VOLTAGE 60 Hz	NOMINAL POWER	NOMINAL CURRENT	NOMINAL TORQUE	R.P.M.	STARTING CURRENT	STARTING TORQUE	MAX TORQUE
230 +/- 10%	220 +/- 5%	1	1	0.83	1.2	0.83	0.83	0.83
230 +/- 10%	230 +/- 10%	1	0.95	0.83	1.2	0.83	0.83	0.83
230 +/- 10%	254 +/- 5%	1.15	1.02	0.96	1.2	0.93	0.93	0.93
230 +/- 10%	277 +/- 5%	1.2	1	1	1.2	1	1	1
400 +/- 10%	380 +/- 5%	1	1	0.83	1.2	0.83	0.83	0.83
400 +/- 10%	400 +/- 10%	1	0.95	0.83	1.2	0.83	0.83	0.83
400 +/- 10%	440 +/- 5%	1.16	1.02	0.96	1.2	0.93	0.93	0.93
400 +/- 10%	460 +/- 10%	1.15	1	0.96	1.2	0.96	0.96	0.96
400 +/- 10%	480 +/- 5%	1.2	1	1	1.2	1	1	1



## FEEDING VOLTAGE

The CHT line motors are made to be used on the European net system Volt 230/400 +/- 10% - Hz 50 and Volt 400/690 +/- 10% - Hz 50

This means that the same motor can function on the following still existing nets:

- 220/380 Volt +/- 5%
- 230/400 Volt +/- 10%
- 240/415 Volt +/- 5%
- 380/660 Volt +/- 5%
- 400/690 Volt +/- 10%
- 415/720 Volt +/- 5%

corresponding to the requirements requested by the rules of numerous countries.



# ELECTRIC MOTORS 2/4/6 POLES

## IE 1

TYPE	POLES	POWER Kw	VOLTAGE V	CURRENT 400 V	TORQUE N/m	EFFICIENCY %	FACTOR COS.φ	WEIGHT Kg.
CHT 56 B2	2	0.13	230/400	0.40	0.42	62.00	0.69	3.20
CHT 56 B4	4	0.09	230/400	0.43	0.64	50.00	0.61	3.20
CHT 63 A2	2	0.18	230/400	0.55	0.63	63.00	0.75	4.00
CHT 63 B2	2	0.25	230/400	0.71	0.88	65.00	0.78	4.40
CHT 63 C2	2	0.37	230/400	1.05	1.30	65.00	0.78	4.90
CHT 63 A4	4	0.12	230/400	0.47	0.85	57.00	0.64	3.90
CHT 63 B4	4	0.18	230/400	0.70	1.27	57.00	0.65	4.50
CHT 63 C4	4	0.22	230/400	0.92	1.77	59.00	0.67	4.80
CHT 63 B6	6	0.12	230/400	0.62	1.27	45.00	0.62	4.80
CHT 71 A2	2	0.37	230/400	0.97	1.29	70.00	0.79	5.60
CHT 71 B2	2	0.55	230/400	1.42	1.90	71.00	0.79	6.10
CHT 71 A4	4	0.25	230/400	0.84	1.77	60.00	0.62	5.60
CHT 71 B4	4	0.37	230/400	1.12	2.58	65.00	0.74	6.20
CHT 71 C4	4	0.55	230/400	1.61	3.81	66.00	0.75	7.00
CHT 71 A6	6	0.18	230/400	0.70	1.95	56.00	0.66	6.00
CHT 71 B6	6	0.25	230/400	0.87	2.65	59.00	0.70	6.50
CHT 71 C6	6	0.37	230/400	1.27	3.97	61.00	0.69	7.20
CHT 80 A4	4	0.55	230/400	1.59	3.81	67.00	0.75	8.90
CHT 80 A6	6	0.37	230/400	1.23	3.93	62.00	0.70	8.20
CHT 80 B6	6	0.55	230/400	1.65	5.80	67.00	0.72	9.90

## IE 2

CHT 80 A2	2	0.75	230/400	1.75	2.51	77.40	0.80	9.10
CHT 80 B2	2	1.10	230/400	2.45	3.69	80.00	0.82	10.70
CHT 80 C2	2	1.50	230/400	3.12	4.97	82.70	0.83	13.00
CHT 80 B4	4	0.75	230/400	1.79	5.04	79.60	0.76	11.20
CHT 80 C4	4	1.10	230/400	2.72	7.39	81.40	0.71	13.50
CHT 90 S2	2	1.50	230/400	3.20	4.95	81.40	0.83	13.30
CHT 90 L2	2	2.20	230/400	4.54	7.38	83.20	0.84	16.00
CHT 90 S4	4	1.10	230/400	2.50	7.37	81.40	0.78	13.90
CHT 90 L4	4	1.50	230/400	3.31	10.09	82.80	0.79	16.20
CHT 90 M4	4	2.20	230/400	5.09	14.71	84.30	0.74	20.50
CHT 90 S6	6	0.75	230/400	2.01	7.66	76.00	0.71	13.00
CHT 90 L6	6	1.10	230/400	2.82	11.23	78.10	0.72	16.30
CHT 100 LA2	2	3.00	230/400	5.88	10.05	84.60	0.87	23.00
CHT 100 LA4	4	2.20	230/400	4.83	14.70	84.30	0.78	22.70
CHT 100 LB4	4	3.00	230/400	6.33	20.00	85.50	0.80	26.50
CHT 100 LA6	6	1.50	230/400	3.71	15.20	80.00	0.73	22.00
CHT 112 M2	2	4.00	230/400	7.56	13.13	86.00	0.89	27.00
CHT 112 M4	4	4.00	230/400	8.23	26.60	86.60	0.81	32.50
CHT 112 L4	4	5.50	230/400	11.25	36.57	87.90	0.80	39.00
CHT 112 M6	6	2.20	230/400	5.17	22.30	81.80	0.75	29.50
CHT 132 SA2	2	5.50	230/400	10.25	18.00	87.20	0.89	40.20
CHT 132 SB2	2	7.50	230/400	13.80	24.47	88.10	0.89	45.00
CHT 132 S4	4	5.50	230/400	11.00	36.22	87.90	0.83	44.00
CHT 132 M4	4	7.50	230/400	14.50	50.00	88.70	0.84	53.50
CHT 132 M6	6	4.00	230/400	8.86	40.42	84.60	0.77	45.00
CHT 132 S6	6	3.00	230/400	6.84	30.48	83.30	0.76	36.10



## IE 3

## IE 3 EFFICIENCY MOTORS

From January 2017, the third phase of the regulation (CE) n° 640/2009 came into force, therefore, starting from this date, the electric motors sold in the European Economic Market at 2, 4 and 6 poles with power included between KW 0,75 and KW 375 Kw must have minimum efficiency IE3, alternatively IE2, if supplied with inverter or destined for countries not belonging to the aforementioned market.

With the entry into force of the third phase, it will be the responsibility of the purchaser to make sure that the IE2 motors, which are included in the regulations, are used as indicated above.

TYPE	POLES	POWER Kw	VOLTAGE V	CURRENT 400 V	TORQUE N/m	EFFICIENCY %	FACTOR COS.φ	WEIGHT Kg.
CHT 80 A2	2	0.75	230/400	1.66	2.51	80.7	0.81	8.5/8.4
CHT 80 B2	2	1.1	230/400	2.31	3.69	82.7	0.83	10.3/10.2
CHT 90 S2	2	1.5	230/400	3.14	5.02	84.2	0.82	14.4/14.3
CHT 90 L2	2	2.2	230/400	4.51	7.38	85.9	0.82	16.3/16.1
CHT 100 LA2	2	3	230/400	5.59	10.05	87.1	0.89	24.1/24.0
CHT 112 M2	2	4	230/400	7.2	13.13	88.1	0.91	30.2/30.1
CHT 132 SA2	2	5.5	230/400	10	18.08	89.2	0.89	44.2/44.00
CHT 132 SB2	2	7.5	230/400	13.4	24.61	90.1	0.90	52.0/52.8
CHT 80 B4	4	0.75	230/400	1.9	5.04	82.2	0.69	12.1/11.3
CHT 90 S4	4	1.1	230/400	2.59	7.37	84.1	0.73	15.0/15.0
CHT 90 L4	4	1.5	230/400	3.43	10.09	85.3	0.74	18.0/18.0
CHT 100 LA4	4	2.2	230/400	4.58	14.69	86.7	0.80	23.5/23.0
CHT 100 LB4	4	3	230/400	6.33	20.03	87.7	0.78	28.2/28.0
CHT 112 M4	4	4	230/400	7.95	26.62	88.6	0.82	32.3/32.0
CHT 132 S4	4	5.5	230/400	10.5	36.73	89.6	0.84	48.0/47.5
CHT 132 M4	4	7.5	230/400	14.3	50.08	90.4	0.84	58.2/58.0
CHT 90 S6	6	0.75	230/400	2.05	7.66	78.9	0.67	14.1/14.0
CHT 10 L6	6	1.1	230/400	2.93	11.23	81.0	0.67	17.8/16.2
CHT 100 LA6	6	1.5	230/400	3.75	15.24	82.5	0.70	22.2/22.0
CHT 112 M6	6	2.2	230/400	5.54	22.35	84.3	0.68	27.0/26.0
CHT 132 S6	6	3	230/400	6.84	30.48	86.6	0.74	40.0/39.0
CHT 132 MA6	6	4	230/400	8.99	40.42	86.8	0.74	47.5/47.2
CHT 132 MB6	6	5.5	230/400	12.7	55.58	88.0	0.71	55.4/54.0

\* Volt 400/690 standard from 160 up to 355 on request for other sizes.

\* **SIEMENS** motor available on request

\* **MGM** brake motor available on request



## B5

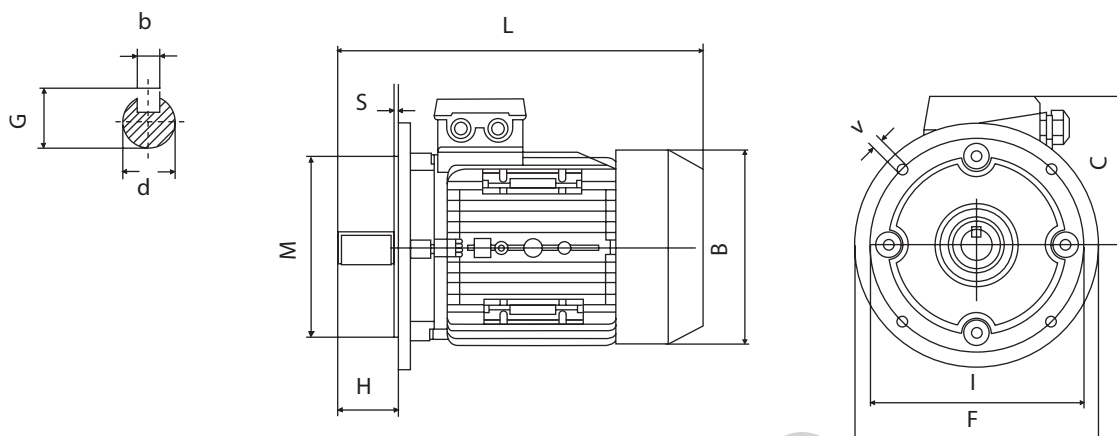

## B14

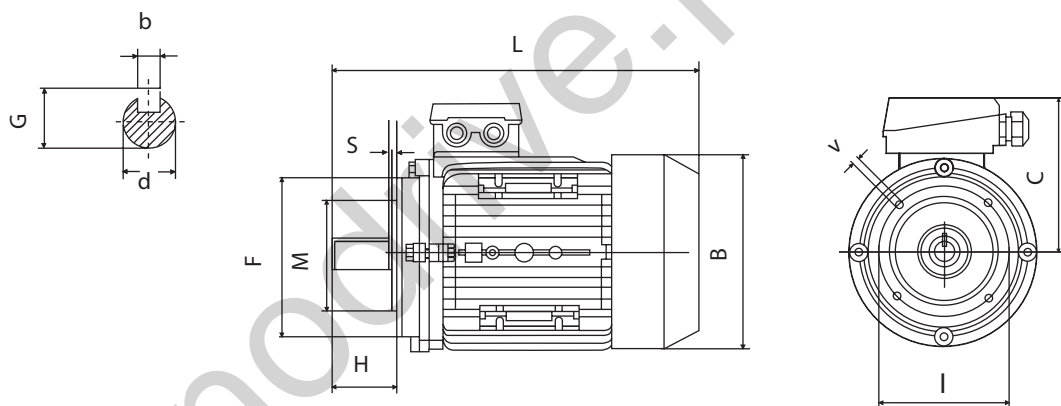

## B3

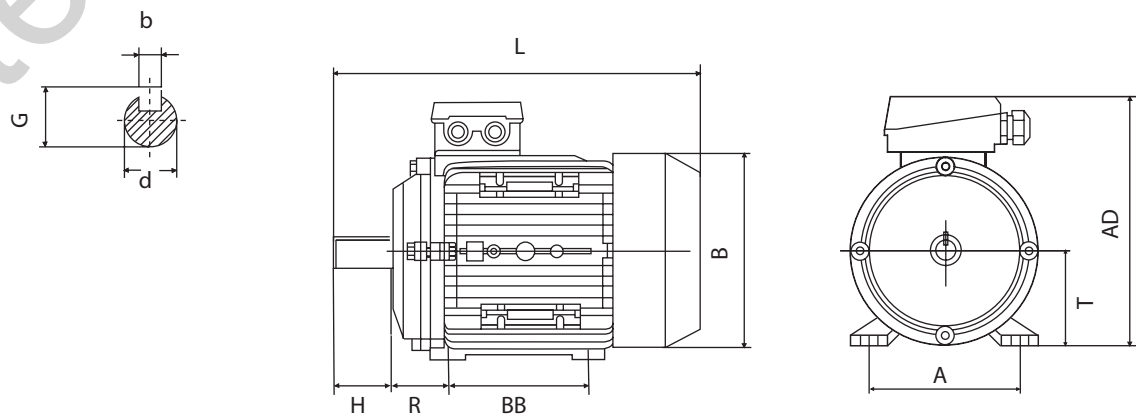



# ELECTRIC MOTORS THREE-PHASE - DIMENSIONS

TYPE	MOUNTING DIMENSIONS (mm)														DIMENSIONS							
	d	H	b	G	B5					B14					B3					B	C	L
					I	M	F	V	S	I	M	F	V	S	R	BB	A	T	AD			
<b>56</b>	9	20	3	10.2	100	80	120	7	3.0	65	50	80	M5	2.5	36	71	90	56	156	110	100	195
<b>63</b>	11	23	4	12.5	115	95	140	10	3.0	75	60	90	M5	2.5	40	80	100	63	173	123	110	215
<b>71</b>	14	30	5	16	130	110	160	10	3.5	85	70	105	M6	2.5	45	90	112	71	188	138	117	255
<b>80</b>	19	40	6	21.5	165	130	200	12	3.5	100	80	120	M6	3.0	50	100	125	80	217	155	137	290
<b>90S</b>	24	50	8	27	165	130	200	12	3.5	115	95	140	M8	3.0	56	100	140	90	235	176	145	310
<b>90L/90LL</b>	24	50	8	27	165	130	200	12	3.5	115	95	140	M8	3.0	56	125	140	90	235	176	145	335
<b>100L</b>	28	60	8	31	215	180	250	15	4.0	130	110	160	M8	3.5	63	140	160	100	252	197	152	386
<b>112M</b>	28	60	8	31	215	180	250	15	4.0	130	110	160	M8	3.5	70	140	190	112	292	220	180	395
<b>132S</b>	38	80	10	41	265	230	300	15	4.0	165	130	200	M10	4.0	89	140	216	132	325	257	195	436
<b>132M</b>	38	80	10	41	265	230	300	15	4.0	165	130	200	M10	4.0	89	178	216	132	325	257	195	475

The dimensions are indicative.



**IE 1 ALUMINUM** $\Delta/Y$  230/400V-50Hz (F112)  $\Delta$  400V-50Hz ( $\geq 132$ )

1. Cl.F - IP55 - IC411

**Duty S1** ( $P_N < 0,75\text{kW}$ ) - **S3** 70% ( $P_N \geq 0,75\text{kW}$ )

Aluminum casing

Efficiency IE1 (IEC60034-30, IEC60034-2-1)

**2 POLES 3000 min<sup>-1</sup>**

$P_N$ [kW]	Motor	Poles	$n_N$ [min <sup>-1</sup> ]	$M_N$ [Nm]	$I_N$ [A]	COS $\varphi$	$\eta$ 100%	$M_S/M_N$	$M_{max}/M_N$	$I_S/I_N$	$J_0$ [kg m <sup>2</sup> ]	W [kg]
11	<b>CHT 132 MC</b>	<b>2</b>	2800	37,5	20,5	0,88	88,0	2,0	2,2	7,0	0,017	65
11	<b>CHT 160 M</b>	<b>2</b>	2800	37,5	20,4	0,88	88,4	2,0	2,3	7,0	0,038	104
15	<b>CHT 160 L</b>	<b>2</b>	2800	51,2	27,5	0,88	89,4	2,0	2,3	7,0	0,045	116
18,5	<b>CHT 160 LB</b>	<b>2</b>	2800	63,1	33,3	0,89	90,0	2,0	2,2	7,0	0,055	130

**4 POLES 1500 min<sup>-1</sup>**

$P_N$ [kW]	Motor	Poles	$n_N$ [min <sup>-1</sup> ]	$M_N$ [Nm]	$I_N$ [A]	COS $\varphi$	$\eta$ 100%	$M_S/M_N$	$M_{max}/M_N$	$I_S/I_N$	$J_0$ [kg m <sup>2</sup> ]	W [kg]
11	<b>CHT 132 MC</b>	<b>4</b>	1440	73,0	21,5	0,84	88,0	2,2	2,3	7,0	0,044	80
11	<b>CHT 160 M</b>	<b>4</b>	1440	73,0	21,4	0,84	88,4	2,2	2,3	7,0	0,075	107
15	<b>CHT 160 L</b>	<b>4</b>	1440	99,5	28,8	0,84	89,4	2,2	2,3	7,0	0,092	128

**6 POLES 1000 min<sup>-1</sup>**

$P_N$ [kW]	Motor	Poles	$n_N$ [min <sup>-1</sup> ]	$M_N$ [Nm]	$I_N$ [A]	COS $\varphi$	$\eta$ 100%	$M_S/M_N$	$M_{max}/M_N$	$I_S/I_N$	$J_0$ [kg m <sup>2</sup> ]	W [kg]
5,5	<b>CHT 132 MB</b>	<b>6</b>	960	54,7	11,9	0,78	85,3	2,0	2,2	6,5	0,046	64
7,5	<b>CHT 160 M</b>	<b>6</b>	940	76,2	16,1	0,78	86,0	2,0	2,0	6,5	0,088	108
11	<b>CHT 160 L</b>	<b>6</b>	940	111,8	23,4	0,78	87,0	2,0	2,0	6,5	0,116	126



## IE 1 CAST IRON

Δ/Y 400/690 V-50Hz

1. Cl.F - IP54 - IC411

Duty S3 70%

Cast iron casing

Efficiency IE1 (IEC60034-30, IEC60034-2-1)

### 2 POLES 3000 min<sup>-1</sup>

P <sub>N</sub> [kW]	Motor	Poles	n <sub>N</sub> [min <sup>-1</sup> ]	M <sub>N</sub> [Nm]	I <sub>N</sub> [A]	COS φ	η 100%	M <sub>s</sub> /M <sub>N</sub>	M <sub>max</sub> /M <sub>N</sub>	I <sub>s</sub> /I <sub>N</sub>	J <sub>0</sub> [kg m <sup>2</sup> ]	W [kg]
22	CHT 180 M	2	2940	71	39	0,90	89,9	2,1	2,3	7,0	0,075	165
30	CHT 200 LA	2	2950	97	53	0,90	90,7	2,0	2,5	6,9	0,12	218
37	CHT 200 LB	2	2950	120	65	0,90	91,2	2,0	2,4	7,2	0,14	230
45	CHT 225 M	2	2960	145	79	0,90	91,7	2,2	2,4	7,3	0,23	280
55	CHT 250 M	2	2965	177	96	0,90	92,1	2,0	2,3	7,1	0,31	365
75	CHT 280 S	2	2970	241	130	0,90	92,7	2,2	2,4	7,3	0,58	495
90	CHT 280 M	2	2970	289	153	0,91	93,0	2,0	2,3	7,0	0,68	565
110	CHT 315 S	2	2975	353	187	0,91	93,3	1,9	2,3	7,1	1,18	840
132	CHT 315 M	2	2975	424	224	0,91	93,5	1,8	2,3	6,6	1,82	980
160	CHT 315 LA	2	2975	514	268	0,92	93,8	1,9	2,3	6,7	2,08	1055
200	CHT 315 LB	2	2975	642	334	0,92	94,0	1,8	2,3	7,0	2,38	1110

### 4 POLES 1500 min<sup>-1</sup>

P <sub>N</sub> [kW]	Motor	Poles	n <sub>N</sub> [min <sup>-1</sup> ]	M <sub>N</sub> [Nm]	I <sub>N</sub> [A]	COS φ	η 100%	M <sub>s</sub> /M <sub>N</sub>	M <sub>max</sub> /M <sub>N</sub>	I <sub>s</sub> /I <sub>N</sub>	J <sub>0</sub> [kg m <sup>2</sup> ]	W [kg]
18,5	CHT 180 M	4	1460	121	35	0,86	89,9	2,1	2,8	6,7	0,14	164
22	CHT 180 L	4	1470	143	41	0,86	89,9	2,2	3,0	7,5	0,16	182
30	CHT 200 L	4	1470	195	56	0,86	90,7	2,3	2,5	6,6	0,26	244
37	CHT 225 S	4	1470	240	67	0,87	91,2	2,3	2,6	7,2	0,41	258
45	CHT 225 M	4	1475	291	81	0,87	91,7	2,2	2,4	7,0	0,47	290
55	CHT 250 M	4	1475	356	99	0,87	92,1	2,3	2,6	7,1	0,66	388
75	CHT 280 S	4	1480	484	134	0,87	92,7	2,3	2,5	6,6	1,12	510
90	CHT 280 M	4	1480	581	161	0,87	93,0	2,2	2,4	6,2	1,46	606
110	CHT 315 S	4	1480	710	193	0,88	93,3	2,2	2,4	7,0	3,11	910
132	CHT 315 M	4	1480	852	232	0,88	93,5	2,2	2,5	6,8	3,62	985
160	CHT 315 LA	4	1480	1032	277	0,89	93,8	2,1	2,4	6,6	4,13	1056
200	CHT 315 LB	4	1480	1291	345	0,89	94,0	2,2	2,4	6,9	4,73	1128

### 6 POLES 1000 min<sup>-1</sup>

P <sub>N</sub> [kW]	Motor	Poles	n <sub>N</sub> [min <sup>-1</sup> ]	M <sub>N</sub> [Nm]	I <sub>N</sub> [A]	COS φ	η 100%	M <sub>s</sub> /M <sub>N</sub>	M <sub>max</sub> /M <sub>N</sub>	I <sub>s</sub> /I <sub>N</sub>	J <sub>0</sub> [kg m <sup>2</sup> ]	W [kg]
15	CHT 180 L	6	970	148	31	0,81	87,7	2,1	2,2	6,9	0,16	178
18,5	CHT 200 LA	6	980	180	37	0,81	88,6	2,1	2,2	6,7	0,26	210
22	CHT 200 LB	6	980	214	43	0,83	89,2	2,1	2,2	6,6	0,28	227
30	CHT 225 M	6	980	292	57	0,84	90,2	2,0	2,1	6,7	0,47	265
37	CHT 250 M	6	980	361	68	0,86	90,8	2,1	2,2	6,9	0,66	370
45	CHT 280 S	6	980	439	83	0,86	91,4	2,1	2,2	6,5	1,12	490
55	CHT 280 M	6	980	536	100	0,86	91,9	2,0	2,1	6,6	1,46	540
75	CHT 315 S	6	985	727	136	0,86	92,6	2,0	2,3	6,8	3,11	800
90	CHT 315 M	6	985	873	163	0,86	92,9	2,1	2,2	6,7	3,62	920
110	CHT 315 LA	6	985	1066	198	0,86	93,3	2,0	2,1	6,6	4,13	960
132	CHT 315 LB	6	985	1280	234	0,87	93,5	2,1	2,3	6,4	4,73	1050

**IE 3 ALUMINUM** $\Delta/Y$  230/400V-50Hz (£112)  $\Delta$  400V-50Hz ( $\geq 132$ )

1. Cl.F - IP55 - IC411

Duty S1

Aluminum casing

Efficiency IE3 (IEC60034-30, IEC60034-2-1)

**2 POLES 3000 min<sup>-1</sup>**

P <sub>N</sub> [kW]	Motor	Poles	n <sub>N</sub> [min <sup>-1</sup> ]	M <sub>N</sub> [Nm]	I <sub>N</sub> [A]	COS φ	η			M <sub>s</sub> /M <sub>N</sub>	M <sub>max</sub> /M <sub>N</sub>	I <sub>s</sub> /I <sub>N</sub>	J <sub>0</sub> [kg m <sup>2</sup> ]	W [kg]
							100%	75%	50%					
11	CHT 160 M	2	2940	35,7	19,6	0,89	91,2	91,4	90,1	2,2	2,3	7,9	0,063	108
15	CHT 160 L	2	2935	48,8	26,5	0,89	91,9	92,2	91,7	2,2	2,3	8,0	0,073	119
18,5	CHT 160 LB	2	2940	60,1	32,4	0,89	92,5	92,9	92,3	2,2	2,3	8,1	0,084	134

**4 POLES 1500 min<sup>-1</sup>**

P <sub>N</sub> [kW]	Motor	Poles	n <sub>N</sub> [min <sup>-1</sup> ]	M <sub>N</sub> [Nm]	I <sub>N</sub> [A]	COS φ	η			M <sub>s</sub> /M <sub>N</sub>	M <sub>max</sub> /M <sub>N</sub>	I <sub>s</sub> /I <sub>N</sub>	J <sub>0</sub> [kg m <sup>2</sup> ]	W [kg]
							100%	75%	50%					
11	CHT 160 M	4	1460	72,0	20,7	0,84	91,4	91,5	91,5	2,2	2,3	7,5	0,096	111
15	CHT 160 L	4	1460	98,1	27,7	0,85	92,1	92,3	92,1	2,2	2,3	7,5	0,133	132

**6 POLES 1000 min<sup>-1</sup>**

P <sub>N</sub> [kW]	Motor	Poles	n <sub>N</sub> [min <sup>-1</sup> ]	M <sub>N</sub> [Nm]	I <sub>N</sub> [A]	COS φ	η			M <sub>s</sub> /M <sub>N</sub>	M <sub>max</sub> /M <sub>N</sub>	I <sub>s</sub> /I <sub>N</sub>	J <sub>0</sub> [kg m <sup>2</sup> ]	W [kg]
							100%	75%	50%					
7,5	CHT 160 M	6	970	73,8	15,8	0,77	89,1	89,3	89,0	2,1	2,1	6,7	0,107	111
15	CHT 160 L	6	970	108,3	22,5	0,78	90,3	90,4	90,0	2,1	2,1	7,2	0,146	132



## IE 3 CAST IRON

Δ/Y 400/690 V-50Hz

1. Cl.F - IP54 - IC411

Duty S1

Cast iron casing

Efficiency IE3 (IEC60034-30, IEC60034-2-1)

### 2 POLES 3000 min<sup>-1</sup>

P <sub>N</sub> [kW]	Motor	Poles	n <sub>N</sub> [min <sup>-1</sup> ]	M <sub>N</sub> [Nm]	I <sub>N</sub> [A]	COS φ	η			M <sub>s</sub> /M <sub>N</sub>	M <sub>max</sub> /M <sub>N</sub>	I <sub>s</sub> /I <sub>N</sub>	J <sub>0</sub> [kg m <sup>2</sup> ]	W [kg]
							100%	75%	50%					
22	CHT 180 M	2	2955	71	38	0,90	92,7	92,7	90,8	2,2	2,3	8,2	0,098	182
30	CHT 200 LA	2	2960	97	52	0,89	93,3	93,3	91,4	2,2	2,3	7,5	0,14	250
37	CHT 200 LB	2	2960	119	63	0,91	93,7	93,7	91,8	2,2	2,3	7,5	0,17	259
45	CHT 225 M	2	2965	145	79	0,88	94,0	94,0	92,1	2,2	2,3	7,6	0,28	324
55	CHT 250 M	2	2970	177	95	0,89	94,3	94,3	92,4	2,2	2,3	7,6	0,40	426
75	CHT 280 S	2	2975	241	127	0,90	94,7	94,7	92,8	2,0	2,3	6,9	0,65	533
90	CHT 280 M	2	2975	289	154	0,89	95,0	95,0	93,1	2,0	2,3	7,0	0,75	812
110	CHT 315 S	2	2975	353	185	0,90	95,2	95,2	93,3	2,0	2,2	7,1	1,45	905
132	CHT 315 M	2	2975	424	222	0,90	95,4	95,4	93,5	2,0	2,2	7,1	2,10	995
160	CHT 315 LA	2	2980	513	268	0,90	95,6	95,6	93,7	2,0	2,2	7,1	2,40	1119
200	CHT 315 LB	2	2980	641	331	0,91	95,8	95,8	93,9	2,0	2,2	7,1	2,60	1150

### 4 POLES 1500 min<sup>-1</sup>

P <sub>N</sub> [kW]	Motor	Poles	n <sub>N</sub> [min <sup>-1</sup> ]	M <sub>N</sub> [Nm]	I <sub>N</sub> [A]	COS φ	η			M <sub>s</sub> /M <sub>N</sub>	M <sub>max</sub> /M <sub>N</sub>	I <sub>s</sub> /I <sub>N</sub>	J <sub>0</sub> [kg m <sup>2</sup> ]	W [kg]
							100%	75%	50%					
18,5	CHT 180 M	4	1470	120	34	0,84	92,6	92,6	90,7	2,2	2,3	7,5	0,14	175
22	CHT 180 L	4	1470	143	40	0,85	93,0	93,0	91,1	2,2	2,3	7,7	0,16	209
30	CHT 200 L	4	1475	194	54	0,86	93,6	93,6	91,7	2,2	2,3	7,8	0,26	275
37	CHT 225 S	4	1485	238	66	0,86	93,9	93,9	92,0	2,2	2,3	7,2	0,41	324
45	CHT 225 M	4	1485	289	79	0,87	94,2	94,2	92,3	2,2	2,3	7,3	0,47	359
55	CHT 250 M	4	1485	354	97	0,87	94,6	94,6	92,7	2,2	2,3	7,4	0,67	433
75	CHT 280 S	4	1485	482	129	0,88	95,0	95,0	93,1	2,2	2,3	7,4	1,13	568
90	CHT 280 M	4	1485	579	157	0,87	95,2	95,2	93,3	2,2	2,3	6,7	1,47	649
110	CHT 315 S	4	1485	707	189	0,88	95,4	95,4	93,5	2,2	2,2	6,9	3,15	935
132	CHT 315 M	4	1485	849	226	0,88	95,6	95,6	93,7	2,2	2,2	6,9	3,65	1020
160	CHT 315 LA	4	1485	1029	274	0,89	95,8	95,8	93,9	2,2	2,2	6,9	4,15	1090
200	CHT 315 LB	4	1490	1282	342	0,89	96,0	96,0	94,1	2,2	2,2	6,9	4,75	1233

### 6 POLES 1000 min<sup>-1</sup>

P <sub>N</sub> [kW]	Motor	Poles	n <sub>N</sub> [min <sup>-1</sup> ]	M <sub>N</sub> [Nm]	I <sub>N</sub> [A]	COS φ	η			M <sub>s</sub> /M <sub>N</sub>	M <sub>max</sub> /M <sub>N</sub>	I <sub>s</sub> /I <sub>N</sub>	J <sub>0</sub> [kg m <sup>2</sup> ]	W [kg]
							100%	75%	50%					
15	CHT 180 L	6	980	146	31	0,81	91,2	91,2	89,4	2,0	2,1	7,2	0,21	193
18,5	CHT 200 LA	6	980	180	36	0,81	91,7	91,7	89,9	2,1	2,1	7,2	0,32	230
22	CHT 200 LB	6	980	214	41	0,83	92,2	92,2	90,4	2,1	2,1	7,3	0,36	243
30	CHT 225 M	6	980	292	56	0,84	92,9	92,9	91,0	2,0	2,1	7,1	0,55	302
37	CHT 250 M	6	985	359	68	0,84	93,3	93,3	91,4	2,1	2,1	7,1	0,85	390
45	CHT 280 S	6	985	436	82	0,85	93,7	93,7	91,8	2,0	2,1	7,2	1,40	505
55	CHT 280 M	6	985	533	99	0,85	94,1	94,1	92,2	2,0	2,1	7,2	1,70	570
75	CHT 315 S	6	985	727	135	0,85	94,6	94,6	92,7	2,0	2,0	6,7	4,15	815
90	CHT 315 M	6	985	873	161	0,85	94,9	94,9	93,0	2,0	2,0	6,7	4,80	955
110	CHT 315 LA	6	985	1066	194	0,86	95,1	95,1	93,2	2,0	2,0	6,7	5,48	1015
132	CHT 315 LB	6	985	1280	232	0,86	95,4	95,4	93,5	2,0	2,0	6,7	6,15	1120



## B3

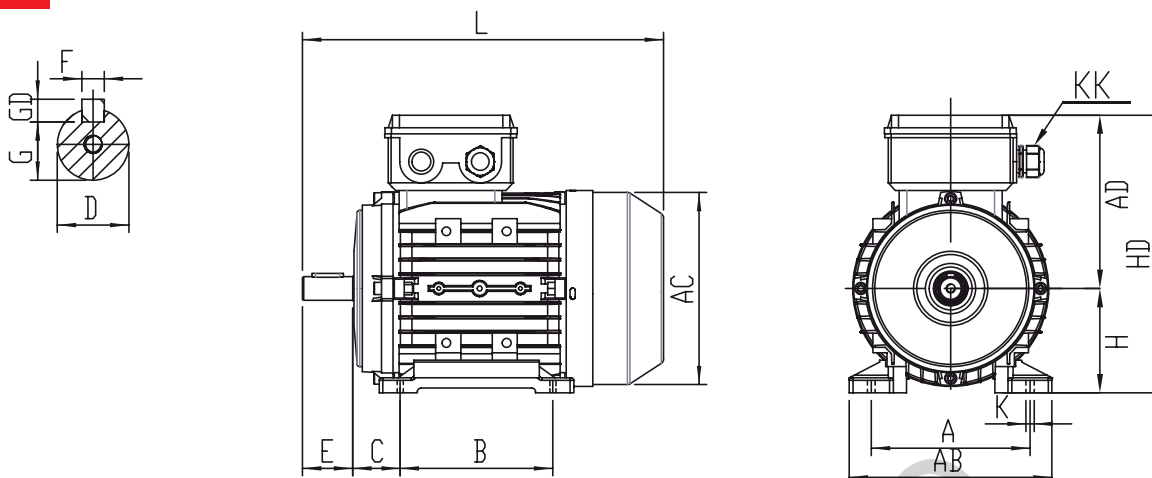

## B5

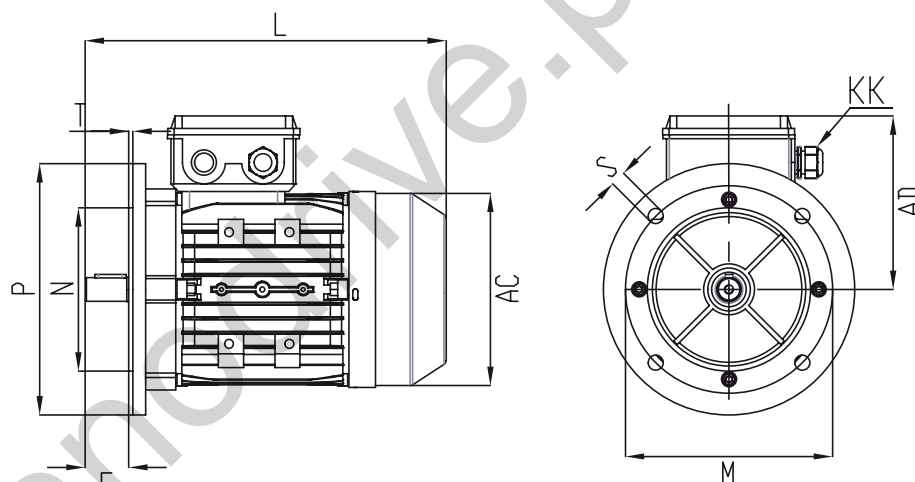

## B14

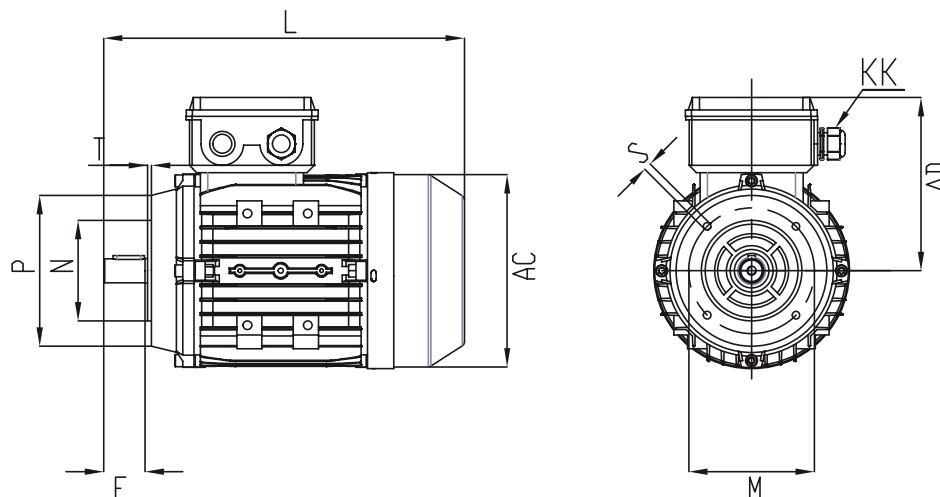



# ELECTRIC MOTORS - DIMENSIONS

Size	Bearings		CableGlands	Terminals	IM B5					IM B14				
	DE	NDE	KK	n. x...	M	N	P	n x S	T	M	N	P	n x S	T
132 M	6308 2RZ	6308 2RZ	M25x1.5	6xM5	265	230 j6	300	4x14,5	4	165	130 j6	200	4xM10	3,5
160 M/L	6309 2RZ	6308 2RZ	M32x1.5	6xM6	300	250 h6	352	4x18,5	5	215	180 j6	250	4xM12	4
180 M/L	6311 2RZ	6311 2RZ	2*M40x1.5	6xM6	300	250 h6	350	4x18,5	5	-	-	-	-	-
200	6312 2RZ	6312 2RZ	2*M50x1.5	6xM8	350	300 h6	400	4x18,5	5	-	-	-	-	-
225 S/M	6213 2RZ	6213 2RZ	2*M50x1.5	6xM8	400	350 h6	450	8x18,5	5	-	-	-	-	-
250	6314 2RZ	6314 2RZ	2*M63x1.5	6xM10	500	450 h6	550	8x18,5	5	-	-	-	-	-
280 S/M	6317 2RZ	6317 2RZ	2*M63x1.5	6xM10	500	450 h6	550	8x18,5	5	-	-	-	-	-
315 S/M/L	6319 2RZ	6319 2RZ	2*M63x1.5	6xM16	600	550 h6	660	8x24	6	-	-	-	-	-

Size	IM B3							Shaft					General				
	A	AB	K	B	C	H	HD	D	E	F	G	GD	AC	AD	L		
132 M	216	255	12	178	89	132	325	38 k6 M12	80	10	33	8	260	193	510		
160 M	254	295	14,5	210	108	160	395	42 k6 M16	110	12	37	8	315	235	610		
160 L				254													
180 M	279	355	14,5	241	121	180	460	48 k6 M16	110	14	42,5	9	355	267	652		
180 L				279											691		
200	318	395	18,5	305	133	200	505	55 m6 M20	110	16	49	10	397	300	746		
225 S	356	435	18,5	286	149	225	560	60 m6 M20	140	18	53	11	446	325	785		
225 M   2p				311				55 m6 M20	110	16	49	10			780		
225 M   4,6p				311				60 m6 M20	140	18	53	11			810		
250   2p	406	490	24	349	168	250	620	60 m6 M20	140	18	53	11	485	360	900		
250   4,6p								65 m6 M20			58						
280 S   2p	457	550	24	368	190	280	690	65 m6 M20	140	18	58	11	547	390	924		
280 S   4,6p				75 m6 M20				20			67,5				12	964	
280 M   2p				65 m6 M20				18			58				11	975	
280 M   4,6p				75 m6 M20				20			67,5				12	1015	
315 S   2p	508	635	28	406	216	315	845	65 m6 M20	140	18	58	11	620	530	1200		
315 S   4,6p				80 m6 M20				170			22				71	14	1230
315 L   2p				65 m6 M20				140			18				58	11	1310
315 L   4,6p				80 m6 M20				170			22				71	14	1340
315 M   2p				65 m6 M20				140			18				58	11	1310
315 M   4,6p				80 m6 M20				170			22				71	14	1340



230V-50Hz  
1. Cl.F - IP55 - IC411  
**Duty S1**  
**Aluminum casing**  
**Running capacitor \***

\* High starting torque with double capacitors, main and auxiliary.

## 2 POLES 3000 min<sup>-1</sup>

P <sub>N</sub> [kW]	Motor	Poles	n <sub>N</sub> [min <sup>-1</sup> ]	M <sub>N</sub> [Nm]	I <sub>N</sub> [A]	COS φ	n 100%	M <sub>S</sub> /M <sub>N</sub>	M <sub>max</sub> /M <sub>N</sub>	I <sub>S</sub> /I <sub>N</sub>	Cap [μF]	J <sub>0</sub> [kg m <sup>2</sup> ]	W [kg]
0,18	CHT 63 A	2	2600	0,7	1,40	0,98	56,9	0,8	1,7	2,4	10	0,0002	4,5
0,25	CHT 63 B	2	2600	0,9	1,85	0,98	60,0	0,8	1,6	2,5	12	0,0003	5,0
0,37	CHT 71 A	2	2650	1,3	2,6	0,98	62,7	0,8	1,7	2,6	16	0,0004	6,8
0,55	CHT 71 B	2	2700	1,9	3,5	0,98	65,9	0,8	1,7	2,7	20	0,0005	7,5
0,75	CHT 80 A	2	2700	2,7	4,9	0,98	67,8	0,8	1,8	2,6	30	0,0010	10
1,1	CHT 80 B	2	2700	3,9	6,8	0,98	71,6	0,7	1,7	2,8	40	0,0012	11
1,5	CHT 90 S	2	2800	5,1	8,7	0,99	75,4	0,7	1,9	3,6	60	0,0019	15
2,2	CHT 90 L	2	2800	7,5	13,1	0,99	77,1	0,7	2,0	3,7	80	0,0026	18
3	CHT 100 LA	2	2850	10,1	17,6	0,99	77,9	0,5	2,1	4,8	80	0,0055	25

## 4 POLES 1500 min<sup>-1</sup>

P <sub>N</sub> [kW]	Motor	Poles	n <sub>N</sub> [min <sup>-1</sup> ]	M <sub>N</sub> [Nm]	I <sub>N</sub> [A]	COS φ	n 100%	M <sub>S</sub> /M <sub>N</sub>	M <sub>max</sub> /M <sub>N</sub>	I <sub>S</sub> /I <sub>N</sub>	Cap [μF]	J <sub>0</sub> [kg m <sup>2</sup> ]	W [kg]
0,12	CHT 63 A	4	1300	0,9	1,1	0,98	51,8	0,8	2,4	1,8	8	0,0003	4,4
0,18	CHT 63 B	4	1300	1,3	1,6	0,98	55,0	0,8	2,4	1,8	10	0,0004	4,8
0,25	CHT 71 A	4	1320	1,8	2,0	0,98	56,6	0,8	2,0	2,1	16	0,0008	6,2
0,37	CHT 71 B	4	1320	2,7	3,0	0,98	58,9	0,8	2,0	2,1	20	0,0010	6,7
0,55	CHT 80 A	4	1350	3,9	3,7	0,98	64,2	0,7	1,8	2,7	25	0,0017	11
0,75	CHT 80 B	4	1350	5,3	5,1	0,99	65,1	0,7	1,7	2,7	35	0,0022	12
1,1	CHT 90 S	4	1350	7,8	7,0	0,99	68,5	0,6	1,7	2,7	50	0,0031	15
1,5	CHT 90 L	4	1350	10,6	9,2	0,99	71,3	0,6	1,7	2,9	65	0,0045	18
2,2	CHT 100 LA	4	1400	15,0	13,0	0,99	75,1	0,5	2,0	4,1	80	0,010	26



# GENERAL TECHNICAL - DIMENSIONS

## B3

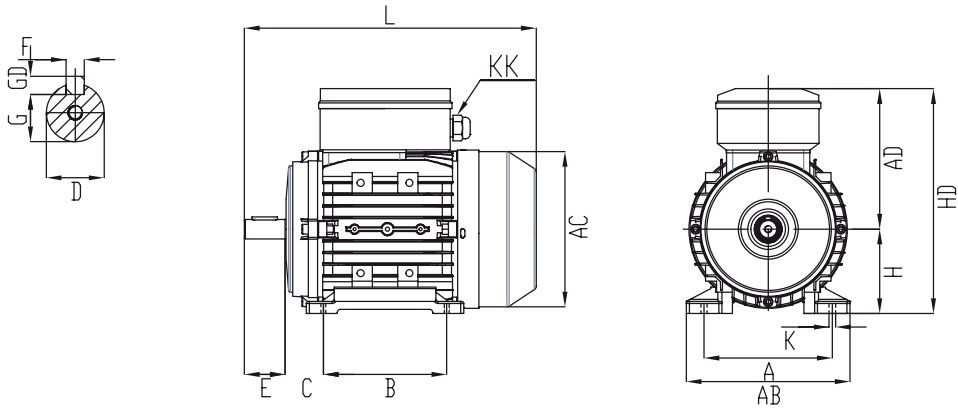

## B5

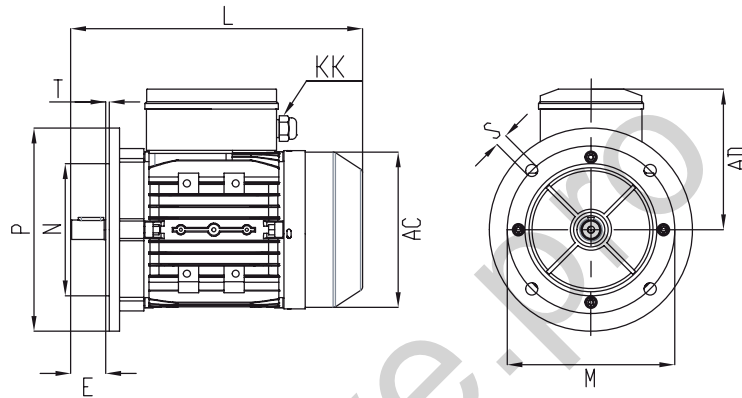

## B14

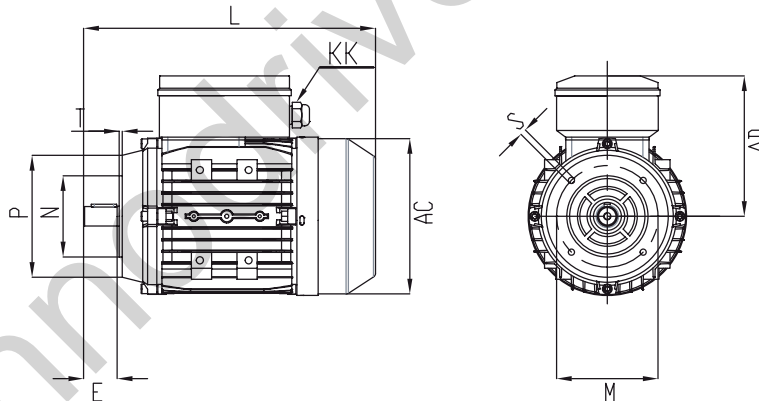

Size	Bearings		CableGlands KK	Terminals n. x...	IM B5					IM B14				
	DE	NDE			M	N	P	n x S	T	M	N	P	n x S	T
63	6201 2RZ	6201 2RZ	M16x1.5	6xM4	115	95 j6	140	4x10	3	75	60 j6	90	4xM5	2,5
71	6202 2RZ	6202 2RZ	M20x1.5	6xM4	130	110 j6	160	4x10	3,5	85	70 j6	105	4xM6	2,5
80	6204 2RZ	6204 2RZ	M20x1.5	6xM4	165	130 j6	200	4x12	3,5	100	80 j6	120	4xM6	3
90 S/L	6205 2RZ	6205 2RZ	M20x1.5	6xM4	165	130 j6	200	4x12	3,5	115	95 j6	140	4xM8	3
100	6206 2RZ	6206 2RZ	M20x1.5	6xM5	215	180 j6	250	4x14,5	4	130	110 j6	160	4xM8	3,5

Size	IM B3							Shaft					General		
	A	AB	K	B	C	H	HD	D	E	F	G	GD	AC	AD	L
63	100	120	7	80	40	63	182	11 j6 M4	23	4	8,5	4	119	119	219
71	112	132	7	90	45	71	197	14 j6 M5	30	5	11	5	137	126	250
80	125	162	10	100	50	80	229	19 j6 M6	40	6	15,5	6	157	149	279
90 S	140	176	10	100	56	90	244	24 j6 M8	50	8	20	7	175	154	353
90 L	140	176	10	125	56	90	244	24 j6 M8	50	8	20	7	175	154	353
100	160	205	12	140	63	100	262	28 j6 M10	60	8	24	7	200	162	389





## SERVO-VENTILATED KITS





# SERVO-VENTILATED KITS MONO-PHASE SERIE

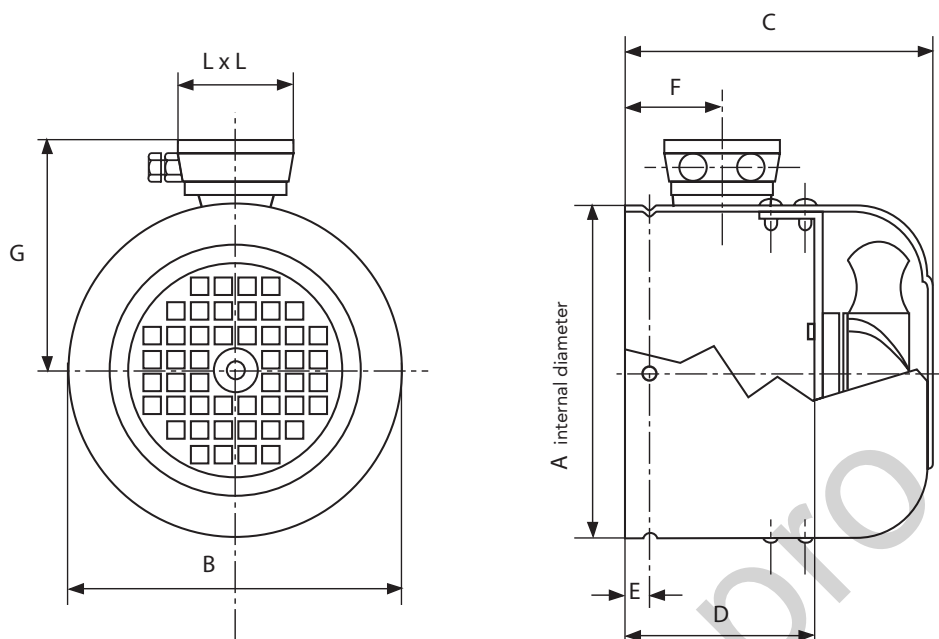

Single-phase dimensions with IP55 terminal box

SIZE	VOLTAGE	HZ	NOM. SPEED MIN/1	ASSORB. WATT	CURRENT M.A.	AIR FLOW M <sup>3</sup> /H
63	230	50 / 60	2750	15 / 14	120 / 100	180
71	230	50 / 60	2750	15 / 14	120 / 100	180
80	230	50 / 60	2750	15 / 14	120 / 100	180
90	230	50 / 60	2900	42 / 36	190 / 180	340
100	230	50 / 60	2900	42 / 36	190 / 180	340
112	230	50 / 60	2900	42 / 36	190 / 180	340
132	230	50 / 60	2900	42 / 36	190 / 180	340

SIZE	COD. IP55	A	B	C	D	E	F	G	L x L
63	AS063230	121	123	102	58	6	50	104	75
71	AS071230	136	138	120	70	6	50	111	75
80	AS080230	153	155	130	80	6	55	125	100
90	AS090230	172	176	145	75	6	60	135	100
100	AS100230	195	197	158	85	8	60	150	100
112	AS112230	218	220	160	100	10	60	160	100
132	AS132230	255	257	180	120	8	65	175	100



## SERVO-VENTILATED KITS THREE-PHASE SERIE

Three-phase 400V and 230/400V IP65

With/without (C/S) terminal box

From g 63 to g 132

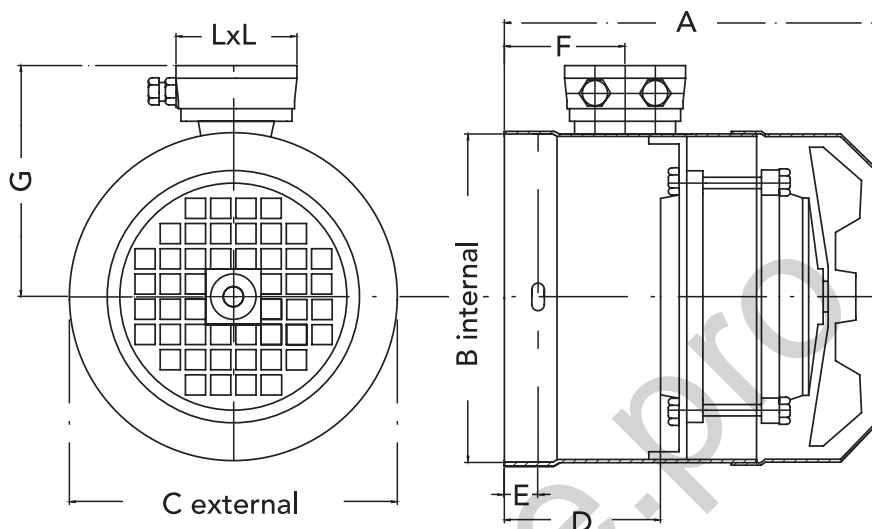

170

SIZE	VOLT	VOLT	Hz	RPM	POWER WATT	ASSORB. (400 V) A	ASSORB. (230/400 V) A	AIR m <sup>3</sup> /h
63	400	230/400	50/60	2900	104	0.26	0.45/0.26	250
71	400	230/400	50/60	2900	104	0.26	0.45/0.26	250
80	400	230/400	50/60	2900	104	0.26	0.45/0.26	300
90	400	230/400	50/60	2900	104	0.26	0.45/0.26	350
100	400	230/400	50/60	2900	104	0.26	0.45/0.26	400
112	400	230/400	50/60	2900	104	0.26	0.45/0.26	450
132	400	230/400	50/60	2900	104	0.26	0.45/0.26	550

SIZE	A	B	C	D	E	F	G	L*L
63	178	120	122	72	6	85	105	75
71	185	136	138	73	6	85	112	75
80	212	154	156	96	6	85	120	75
90	203	174	176	90	6	75	130	75
100	205	191	193	81	6	70	140	75
112	228	219	221	105	8	93	150	75
132	252	256	258	120	8	111	170	75



## BELT TENSIONER SLIDES FOR ELECTRIC MOTORS

### MATERIAL

Galvanized metal sheet **FE 430**

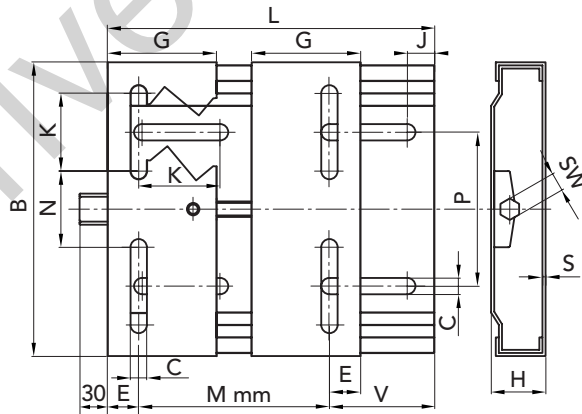

### DIMENSIONS

MOTOR SIZE	TYPE	CODE	L	B	H	Mmin	G	E	J	K	C	N	P	SW	S
63/80	210	90100210	210	195	33	100	70	20	25	50	10,5	43	98	19	3
63/112	270	90100270	270	195	33	100	70	20	25	50	10,5	43	98	19	3
90/132	340	90100340	340	290	40	135	95	27	29	62,5	12,5	90	165	22	4
100/160	430	90100430	460	290	40	140	95	27	29	62,5	12,5	90	165	22	4
160/180	490	90100490	490	410	40	254	95	40	30	60	15	193	142/284	22	4

### ADJUSTMENT WIDENESS

TYPE	63	71	80	90	100	112	132	160	180	WEIGHT kg
210	70	58	45							2,2
270	130	118	105	90	70	40				2,8
340				140	130	100	75			6,7
430					216	186	10	122		7,5
490								156	131	10,8

Quantities, prices and availability by B2B Chiaravalli



# GENERAL SALES CONDITIONS

**1) ORDERS** - Orders for special and standard material must always refer to offers made by CHIARAVALLI GROUP S.p.A. The orders are binding for the client. Once work has commenced no cancellations or order reductions will be accepted unless the client reimburses the costs of the material and the work carried out up to the moment in which the order was suspended.

The quantity despatched can vary by  $\pm 5\%$  compared to the quantity ordered.

**2) PRICES** - The prices are those in force at the date of order.

All prices are for goods delivered ex-works Premazzo, packing excluded. If there should be any increase in production and material costs over the duration of the supply, CHIARAVALLI GROUP S.p.A. reserves the right to adapt the prices accordingly, even for orders in course.

**3) TERMS OF DELIVERY** - Only the terms of delivery indicated by CHIARAVALLI GROUP SpA are to be considered valid. However, they must only be considered as indicative.

In the event of difficulty in the procurement of materials, strikes or in any event in all cases of force majeure, the terms of delivery will be automatically extended without CHIARAVALLI GROUP S.p.A. having to pay any reimbursement for damages.

The client is obligated to collect special material ordered when ready.

**4) DELIVERIES** - Deliveries are the responsibility of the purchaser and are carried out at his own risk and peril.

Any claims for shortages must be presented within 8 days of receipt of the goods.

If it is agreed that the cost of transport is to be paid, even if only in part, by CHIARAVALLI GROUP S.p.A., the latter reserves the right to choose the most economical means of transport.

**5) PACKING** - Packing will be invoiced at cost.

**6) RETURNS** - No returns for any reason will be accepted unless previously authorised and with packing, any customs clearance and the return paid for by the purchaser.

To cover warehouse and administrative expenses a debit note will be issued for approx. 15% of the value of the goods returned.

**7) WARRANTY** - CHIARAVALLI GROUP S.p.A. promises to repair or substitute free of charge any parts that they recognise as being defective. The questioned goods must be returned to the factory of CHIARAVALLI GROUP S.p.A., free of all expenses.

The warranty will be considered cancelled in the event that the parts returned as defective have been repaired or tampered with. The repair of defective parts carried out by the purchaser will only be accepted after authorisation from CHIARAVALLI GROUP S.p.A. and after their approval of the cost estimate. CHIARAVALLI GROUP S.p.A. does not accept responsibility or pay any reimbursement for damages that occur during the use of their products, even if defective.

Warranty is excluded for leakage of lubricant caused by wear of the oil seals.

**8) RESPONSIBILITY** - CHIARAVALLI GROUP S.p.A. does not accept responsibility or pay any reimbursement for damages that occur during the use of their products, even if defective.

CHIARAVALLI GROUP S.p.A. declines all responsibility in the execution of parts to a client's design under any patents.

**9) PAYMENTS** - Only payments carried out in the manner and terms agreed will be considered valid. Once the due date of payment has passed, CHIARAVALLI GROUP S.p.A. will calculate the interest on delayed payment at a rate that is 3% higher than the legal one, retaining the right to demand payment. In the event of delayed or missing payment by the purchaser, the company CHIARAVALLI GROUP S.p.A. reserves the right to suspend deliveries of the orders in course or to demand advance payment without having to pay any reimbursement or compensation to the purchaser. Any dispute regarding materials in manufacture or already possessed by the purchaser does not free the latter from the commitment of making the payment by the agreed date and for the whole amount of the invoice without making any deductions.

**10) OWNERSHIP** - All of the goods despatched remain the property of CHIARAVALLI GROUP S.p.A. until the invoice is fully paid.

**11) COMPETENT COURT** - Any controversy concerning business relations with CHIARAVALLI GROUP SpA will be dealt with under the jurisdiction of the Court of Busto Arsizio.

CHIARAVALLI GROUP SpA, do not accepts responsibility for any errors in the production of this catalogue and reserves the right to add to the drawings designs of the listed products any modification request by manufacturing requirements or due to evolution of the products.

technodrive.pro