

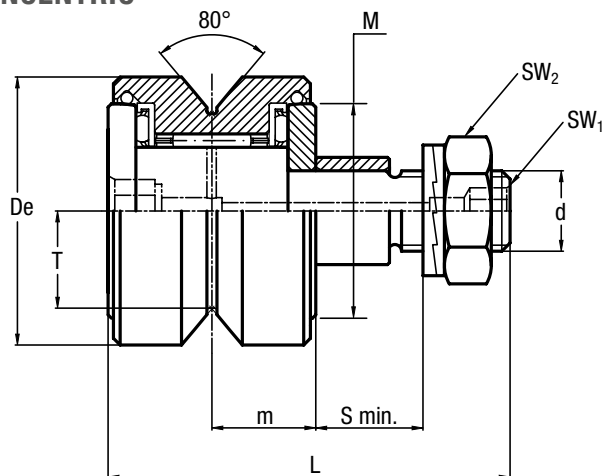

## CONCENTRIC

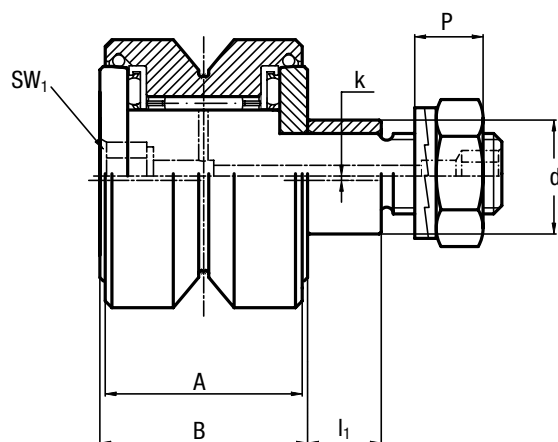

## ECCENTRIC



Desingnation		Dimensions (mm)														
concentric	eccentric	De	d <sub>1</sub> <sup>2)</sup>	d	T	m	S min.	P	L	A	B	l <sub>1</sub>	M	SW <sub>1</sub>	SW <sub>2</sub>	k
FRN 19 EI <sup>1)</sup>	FRNR 19 EI <sup>1)</sup>	19	7	M5 x 0.8	7	8.8	6.5	4.2	34	17	18	5.5	14	<sup>3)</sup>	8	0.5
FRN 22 EI <sup>1)</sup>	FRNR 22 EI <sup>1)</sup>	22	9	M6 x 1	7.7	9.4	9	6.5	39	18.2	20	8	16.5	<sup>3)</sup>	10	0.5
FRN 32 EI <sup>1)</sup>	FRNR 32 EI <sup>1)</sup>	32	14	M10 x 1.25	11.8	12.6	12	10.4	52	24.2	26	11	25	4	16	1
FRN 40 EI <sup>3)</sup>	FRNR 40 EI <sup>3)</sup>	40	16	M12 x 1.5	14.6	15.5	12	11.4	60	29.4	31	11	32	8	19	1

1) Lubrication hole only on head side

2) Housing bore tolerance: H7. Lubrication hole also on stud side

3) Relubrication hole at the roller and stud side

For size 19 and 22: screw driver slot on the head and hexagonal socket at the threaded end of the stud

Desingnation		Dynamic load (N)		Limit loads (N)		Torque wrench settings (Nm)	Weight (g)
		C <sub>wr</sub>	C <sub>wa</sub>	Radial F <sub>r</sub>	Axial F <sub>a</sub>		
FRN 19 EI	FRNR 19 EI	1800	600	490	270	1.8	35
FRN 22 EI	FRNR 22 EI	3280	800	590	290	3	53
FRN 32 EI	FRNR 32 EI	5600	2100	2030	950	20	160
FRN 40 EI	FRNR 40 EI	12300	2600	2800	1350	26	290